

Vessel	Average Radius, mm	Number
Aorta	12.5	1
Arteries	2.0	159
Arterioles	0.03	1.4×10^7
Capillaries	0.006	3.9×10^9

5.10 Air flows steadily between two cross sections in a long, straight section of 0.1-m-inside-diameter pipe. The static temperature and pressure at each section are indicated in Fig. P5.10. If the average air velocity at section (1) is 205 m/s, determine the average air velocity at section (2).

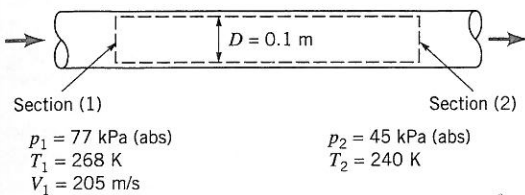

Figure P5.10

5.11 A hydraulic jump (see Video V10.11) is in place downstream from a spillway as indicated in Fig. P5.11. Upstream of the jump, the depth of the stream is 0.6 ft and the average stream velocity is 18 ft/s. Just downstream of the jump, the average stream velocity is 3.4 ft/s. Calculate the depth of the stream, h , just downstream of the jump.

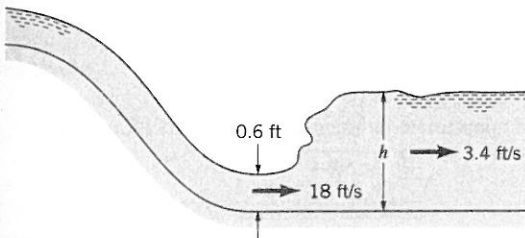

Figure P5.11

5.12 Water enters a rigid, sealed, cylindrical tank at a steady rate of 100 liters/hr and forces gasoline ($SG = 0.68$) out as is indicated in Fig. P5.12. What is the time rate of change of mass of gasoline contained in the tank?

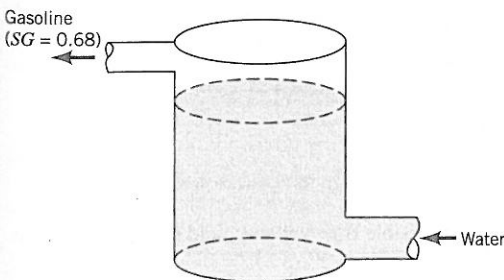

Figure P5.12

5.13 An evaporative cooling tower (see Fig. P5.13) is used to cool water from 110 to 80 °F. Water enters the tower at a rate of 250,000 lbm/hr. Dry air (no water vapor) flows into the tower at a rate of 151,000 lbm/hr. If the rate of wet airflow out of the tower is 156,900 lbm/hr, determine the rate of water evaporation in lbm/hr and the rate of cooled water flow in lbm/hr.

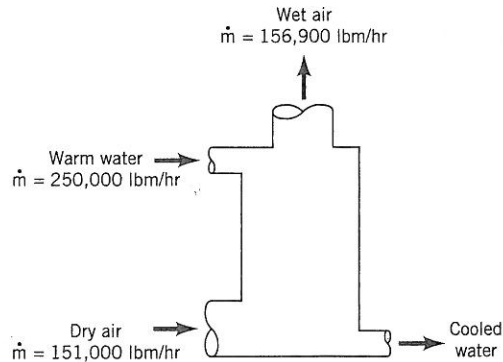

Figure P5.13

5.14 At cruise conditions, air flows into a jet engine at a steady rate of 65 lbm/s. Fuel enters the engine at a steady rate of 0.60 lbm/s. The average velocity of the exhaust gases is 1500 ft/s relative to the engine. If the engine exhaust effective cross-sectional area is 3.5 ft², estimate the density of the exhaust gases in lbm/ft³.

5.15 Water at 0.1 m³/s and alcohol ($SG = 0.8$) at 0.3 m³/s are mixed in a y-duct as shown in Fig. 5.15. What is the average density of the mixture of alcohol and water?

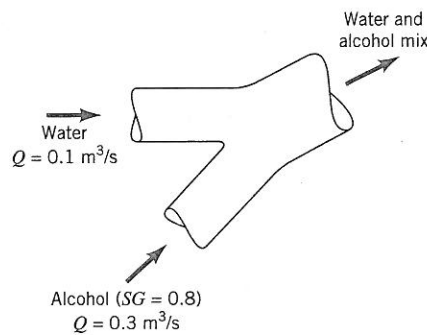

Figure P5.15

5.16 Oil having a specific gravity of 0.9 is pumped as illustrated in Fig. P5.16 with a water jet pump. The water volume flowrate is 1 m³/s. The water and oil mixture has an average specific gravity of 0.95. Calculate the rate, in m³/s, at which the pump moves oil.

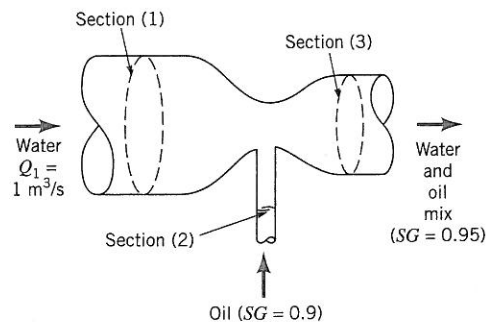
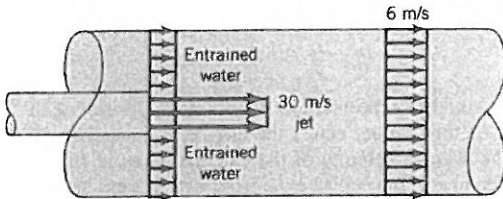

Figure P5.16

5.17 Fresh water flows steadily into an open 55-gal drum initially filled with seawater. The fresh water mixes thoroughly with the seawater, and the mixture overflows out of the drum. If the fresh water flowrate is 10 gal/min, estimate the time in seconds required to decrease the difference between the density of the mixture and the density of fresh water by 50%.

Section 5.1.2 Fixed, Nondeforming Control Volume—Nonuniform Velocity Profile

5.18 A water jet pump (see Fig. P5.18) involves a jet cross-sectional area of 0.01 m², and a jet velocity of 30 m/s. The jet is surrounded by entrained water. The total cross-sectional area associated with the jet and entrained streams is 0.075 m². These two fluid streams leave the pump thoroughly mixed with an average velocity of 6 m/s through a cross-sectional area of 0.075 m². Determine the pumping rate (i.e., the entrained fluid flowrate) involved in liters/s.



■ Figure P5.18

*5.19 To measure the mass flowrate of air through a 6-in.-inside-diameter pipe, local velocity data are collected at different radii from the pipe axis (see Table). Determine the mass flowrate corresponding to the data listed in the following table.

r (in.)	Axial Velocity (ft/s)
0	30
0.2	29.71
0.4	29.39
0.6	29.06
0.8	28.70
1.0	28.31
1.2	27.89
1.4	27.42
1.6	26.90
1.8	26.32
2.0	25.64
2.2	24.84
2.4	23.84
2.6	22.50
2.8	20.38
2.9	18.45
2.95	16.71
2.98	14.66
3.00	0

5.20 Two rivers merge to form a larger river as shown in Fig. P5.20. At a location downstream from the junction (before the two streams completely merge), the nonuniform velocity profile is as shown and the depth is 6 ft. Determine the value of V .

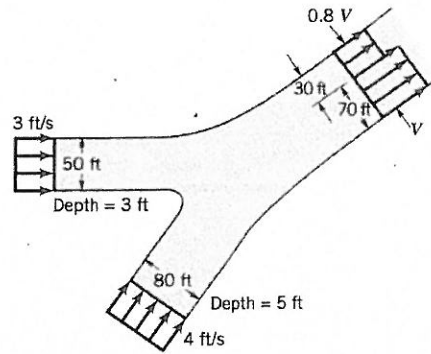

■ Figure P5.20

5.21 Various types of attachments can be used with the shop vac shown in Video V5.2. Two such attachments are shown in Fig. P5.21—a nozzle and a brush. The flowrate is 1 ft³/s. (a) Determine the average velocity through the nozzle entrance, V_n . (b) Assume the air enters the brush attachment in a radial direction all around the brush with a velocity profile that varies linearly from 0 to V_b along the length of the bristles as shown in the figure. Determine the value of V_b .

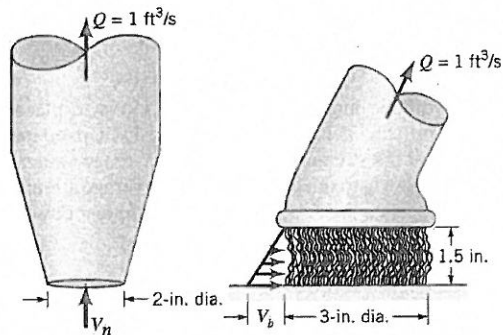

■ Figure P5.21

5.22 An appropriate turbulent pipe flow velocity profile is

$$\mathbf{V} = u_c \left(\frac{R-r}{R} \right)^{1/n} \hat{\mathbf{i}}$$

where u_c = centerline velocity, r = local radius, R = pipe radius, and $\hat{\mathbf{i}}$ = unit vector along pipe centerline. Determine the ratio of average velocity, \bar{u} , to centerline velocity, u_c , for (a) $n = 4$, (b) $n = 6$, (c) $n = 8$, (d) $n = 10$. Compare the different velocity profiles.

5.23 As shown in Fig. P5.23, at the entrance to a 3-ft-wide channel the velocity distribution is uniform with a velocity V . Further downstream the velocity profile is given by $u = 4y - 2y^2$, where u is in ft/s and y is in ft. Determine the value of V .

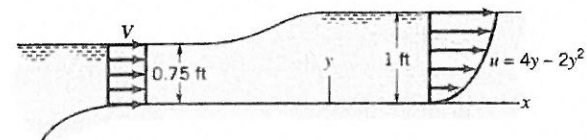

■ Figure P5.23

5.24 An incompressible flow velocity field (water) is given as

$$\mathbf{V} = -\frac{1}{r} \hat{\mathbf{e}}_r + \frac{1}{r} \hat{\mathbf{e}}_\theta \text{ m/s}$$

where r is in meters. (a) Calculate the mass flowrate through the cylindrical surface at $r = 1$ m from $z = 0$ to $z = 1$ m as shown in Fig. P5.24a. (b) Show that mass is conserved in the annular control volume from $r = 1$ m to $r = 2$ m and $z = 0$ to $z = 1$ m as shown in Fig. P5.24b.

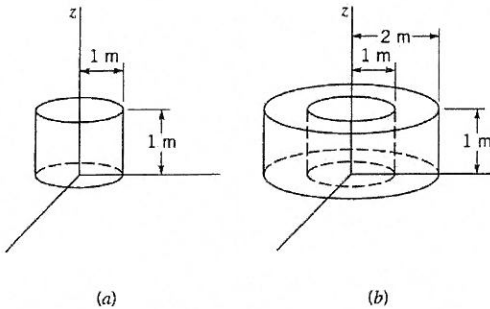

Figure P5.24

5.25 Flow of a viscous fluid over a flat plate surface results in the development of a region of reduced velocity adjacent to the wetted surface as depicted in Fig. P5.25. This region of reduced flow is called a boundary layer. At the leading edge of the plate, the velocity profile may be considered uniformly distributed with a value U . All along the outer edge of the boundary layer, the fluid velocity component parallel to the plate surface is also U . If the x -direction velocity profile at section (2) is

$$\frac{u}{U} = \left(\frac{y}{\delta}\right)^{1/7}$$

develop an expression for the volume flowrate through the edge of the boundary layer from the leading edge to a location downstream at x where the boundary layer thickness is δ .

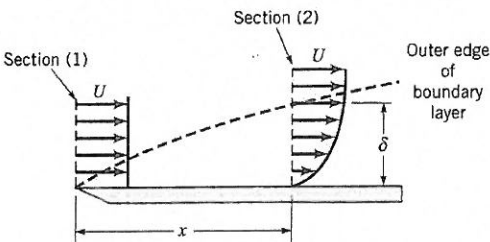

Figure P5.25

Section 5.1.2 Fixed, Nondeforming Control Volume—Unsteady Flow

5.26 Air at standard conditions enters the compressor shown in Fig. P5.26 at a rate of $10 \text{ ft}^3/\text{s}$. It leaves the tank through a 1.2-in.-diameter pipe with a density of $0.0035 \text{ slugs/ft}^3$ and a uniform speed of 700 ft/s . (a) Determine the rate (slugs/s) at which the mass of air in the tank is increasing or decreasing. (b) Determine the average time rate of change of air density within the tank.

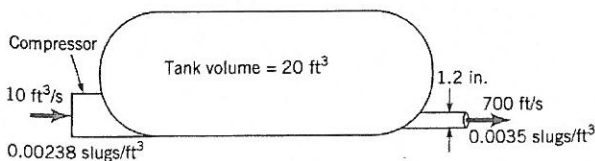

Figure P5.26

5.27 Estimate the time required to fill with water a cone-shaped container (see Fig. P5.27) 5 ft high and 5 ft across at the top if the filling rate is 20 gal/min .

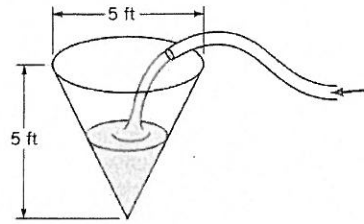

Figure P5.27

5.28 How long would it take to fill a cylindrical-shaped swimming pool having a diameter of 8 m to a depth of 1.5 m with water from a garden hose if the flowrate is 1.0 liter/s ?

Section 5.1.3 Moving, Nondeforming Control Volume

†5.29 For an automobile moving along a highway, describe the control volume you would use to estimate the flowrate of air across the radiator. Explain how you would estimate the velocity of that air.

Section 5.1.4 Deforming Control Volume

5.30 A hypodermic syringe (see Fig. P5.30) is used to apply a vaccine. If the plunger is moved forward at the steady rate of 20 mm/s and if vaccine leaks past the plunger at 0.1 of the volume flowrate out the needle opening, calculate the average velocity of the needle exit flow. The inside diameters of the syringe and the needle are 20 mm and 0.7 mm.

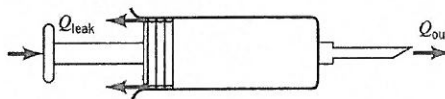

Figure P5.30

5.31 The Hoover Dam (see Video V2.4) backs up the Colorado River and creates Lake Mead, which is approximately 115 miles long and has a surface area of approximately 225 square miles. If during flood conditions the Colorado River flows into the lake at a rate of 45,000 cfs and the outflow from the dam is 8000 cfs, how many feet per 24-hour day will the lake level rise?

5.32 Storm sewer backup causes your basement to flood at the steady rate of 1 in. of depth per hour. The basement floor area is 1500 ft^2 . What capacity (gal/min) pump would you rent to (a) keep the water accumulated in your basement at a constant level until the storm sewer is blocked off, and (b) reduce the water accumulation in your basement at a rate of 3 in./hr even while the backup problem exists?

5.33 (See Fluids in the News article “New 1.6-gpf standards,” Section 5.1.2.) When a toilet is flushed, the water depth, h , in the tank as a function of time, t , is as given in the table. The size of the rectangular tank is 19 in. by 7.5 in. (a) Determine the volume of water used per flush, gpf. (b) Plot the flowrate for $0 \leq t \leq 6 \text{ s}$.

t (s)	h (in.)
0	5.70
0.5	5.33
1.0	4.80
2.0	3.45
3.0	2.40
4.0	1.50
5.0	0.75
6.0	0

Section 5.2.1 Derivation of the Linear Momentum Equation

5.34 A fluid flows steadily in the x direction through a control volume. Measurements indicate that to cause this flow the force acting on the contents of the control volume is 120 N in the negative x direction. Determine the net rate of flow of linear momentum through the control surface.

5.35 Consider the unsteady flow of a fluid in the x direction through a control volume. The linear momentum of the fluid within the control volume is a function of time given by $200t \hat{i}$ slug · ft/s, where t is in seconds and \hat{i} is a unit vector in the x direction. Measurements indicate that to cause this flow the force acting on the contents of the control volume is $40 \hat{i}$ lb. Determine the net rate of flow of linear momentum through the control surface.

Section 5.2.2 Application of the Linear Momentum Equation (also see Lab Problems 5.1LP, 5.2LP, 5.3LP, and 5.4LP)

5.36 A 10-mm-diameter jet of water is deflected by a homogeneous rectangular block (15 mm by 200 mm by 100 mm) that weighs 6 N as shown in Video V5.6 and Fig. P5.36. Determine the minimum volume flowrate needed to tip the block.

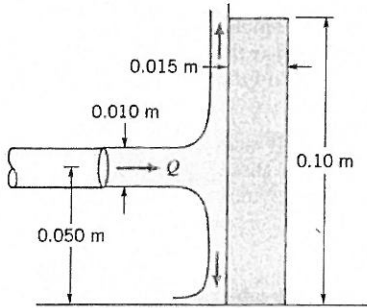

Figure P5.36

†5.37 When a baseball player catches a ball, the force of the ball on her glove is as shown as a function of time in Fig. P5.37. Describe how this situation is similar to the force generated by the deflection of a jet of water by a vane. *Note:* Consider many baseballs being caught in quick succession.

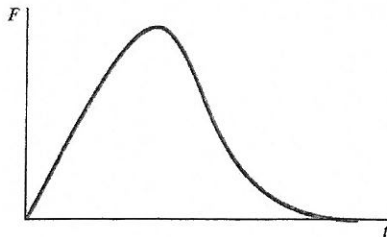

Figure P5.37

5.38 Determine the anchoring force required to hold in place the conical nozzle attached to the end of the laboratory sink faucet shown in Fig. P5.38 when the water flowrate is 10 gal/min. The nozzle weight is 0.2 lb. The nozzle inlet and exit inside diameters are 0.6 and 0.2 in., respectively. The nozzle axis is vertical, and the axial distance between sections (1) and (2) is 1.2 in. The pressure at section (1) is 68 psi.

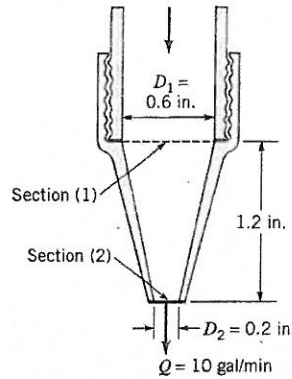

Figure P5.38

5.39 Water flows through a horizontal, 180° pipe bend as is illustrated in Fig. P5.39. The flow cross-sectional area is constant at a value of 9000 mm². The flow velocity everywhere in the bend is 15 m/s. The pressures at the entrance and exit of the bend are 210 and 165 kPa, respectively. Calculate the horizontal (x and y) components of the anchoring force needed to hold the bend in place.

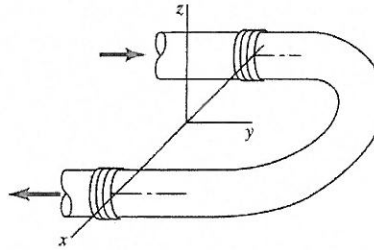

Figure P5.39

5.40 Water flows through a horizontal bend and discharges into the atmosphere as shown in Fig. P5.40. When the pressure gage reads 10 psi, the resultant x -direction anchoring force, F_{Ax} , in the horizontal plane required to hold the bend in place is shown on the figure. Determine the flowrate through the bend and the y -direction anchoring force, F_{Ay} , required to hold the bend in place. The flow is not frictionless.

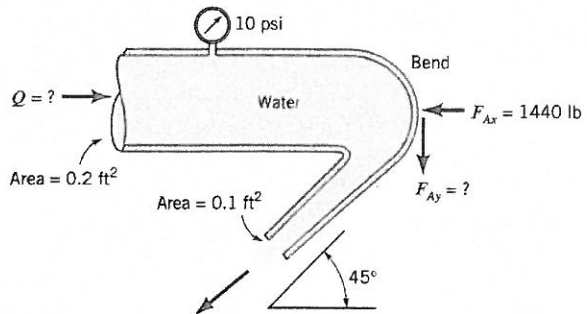
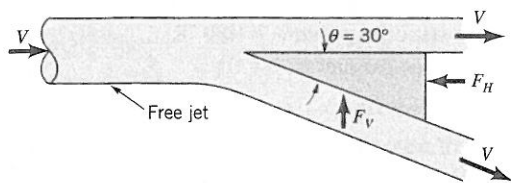

Figure P5.40

5.41 A free jet of fluid strikes a wedge as shown in Fig. P5.41. Of the total flow, a portion is deflected 30°; the remainder is not deflected. The horizontal and vertical components of force needed

to hold the wedge stationary are F_H and F_V , respectively. Gravity is negligible, and the fluid speed remains constant. Determine the force ratio, F_H/F_V .



■ Figure P5.41

5.42 Water enters the horizontal, circular cross-sectional, sudden contraction nozzle sketched in Fig. P5.42 at section (1) with a uniformly distributed velocity of 25 ft/s and a pressure of 75 psi. The water exits from the nozzle into the atmosphere at section (2) where the uniformly distributed velocity is 100 ft/s. Determine the axial component of the anchoring force required to hold the contraction in place.

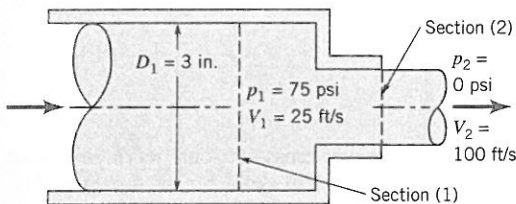

■ Figure P5.42

†5.43 A truck carrying chickens is too heavy for a bridge that it needs to cross. The empty truck is within the weight limits; with the chickens it is overweight. It is suggested that if one could get the chickens to fly around the truck (i.e., by banging on the truck side) it would be safe to cross the bridge. Do you agree? Explain.

5.44 Exhaust (assumed to have the properties of standard air) leaves the 4-ft-diameter chimney shown in Video V5.4 and Fig. P5.44 with a speed of 6 ft/s. Because of the wind, after a few diameters downstream the exhaust flows in a horizontal direction with the speed of the wind, 15 ft/s. Determine the horizontal component of the force that the blowing wind exerts on the exhaust gases.

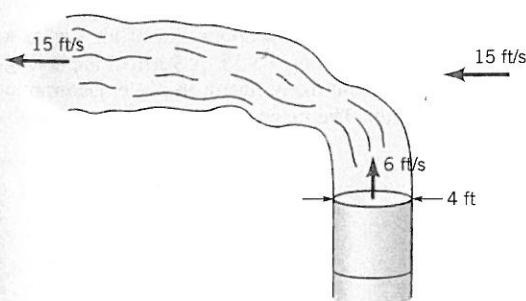

■ Figure P5.44

5.45 Air flows steadily between two cross sections in a long, straight section on 12-in.-inside-diameter pipe. The static temperature and pressure at each section are indicated in Fig P5.45. If the average air velocity at section (2) is 320 m/s, determine the average air velocity at section (1). Determine the frictional force exerted by the pipe wall on the air flowing between sections (1) and (2). Assume uniform velocity distributions at each section.

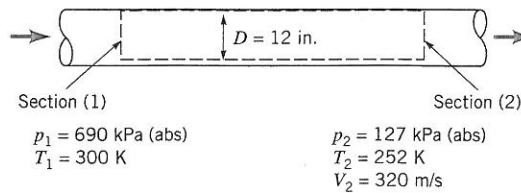

■ Figure P5.45

5.46 Water flows steadily from a tank mounted on a cart as shown in Fig. 5.46. After the water jet leaves the nozzle of the tank, it falls and strikes a vane attached to another cart. The cart's wheels are frictionless, and the fluid is inviscid. (a) Determine the speed of the water leaving the tank, V_1 , and the water speed leaving the cart, V_2 . (b) Determine the tension in rope A. (c) Determine the tension in rope B.

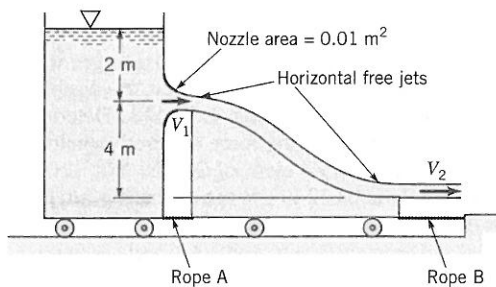

■ Figure P5.46

5.47 Determine the magnitude and direction of the anchoring force needed to hold the horizontal elbow and nozzle combination shown in Fig. P5.47 in place. Atmospheric pressure is 100 kPa(absolute). The gage pressure at section (1) is 100 kPa. At section (2), the water exits to the atmosphere.

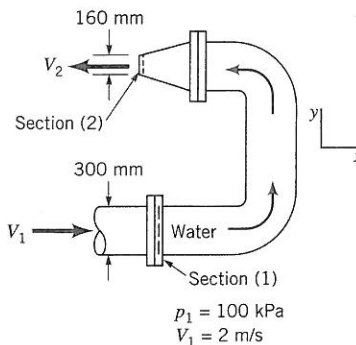

■ Figure P5.47

5.48 Water is added to the tank shown in Fig. P5.48 through a vertical pipe to maintain a constant (water) level. The tank is placed

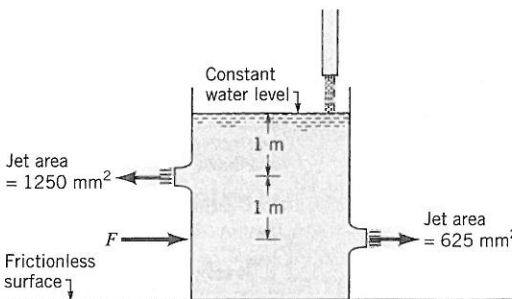

■ Figure P5.48

on a horizontal plane which has a frictionless surface. Determine the horizontal force, F , required to hold the tank stationary. Neglect all losses.

5.49  Water flows as two free jets from the tee attached to the pipe shown in Fig. P5.49. The exit speed is 15 m/s. If viscous effects and gravity are negligible, determine the x and y components of the force that the pipe exerts on the tee.

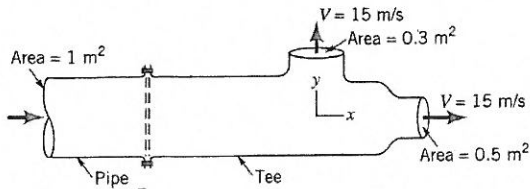

■ Figure P5.49

5.50 A nozzle is attached to a vertical pipe and discharges water into the atmosphere as shown in Fig. P5.50. When the discharge is $0.1 \text{ m}^3/\text{s}$, the gage pressure at the flange is 40 kPa. Determine the vertical component of the anchoring force required to hold the nozzle in place. The nozzle has a weight of 200 N, and the volume of water in the nozzle is 0.012 m^3 . Is the anchoring force directed upward or downward?

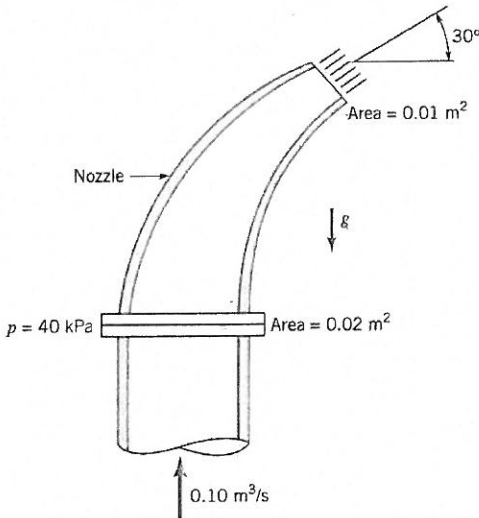

■ Figure P5.50

5.51  The hydraulic dredge shown in Fig. P5.51 is used to dredge sand from a river bottom. Estimate the thrust needed from the propeller to hold the boat stationary. Assume the specific gravity of the sand/water mixture is $SG = 1.4$.

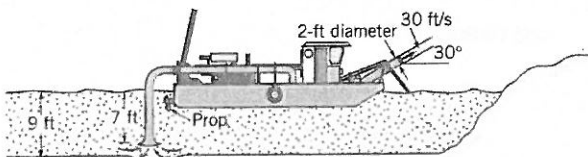

■ Figure P5.51

5.52  A static thrust stand is to be designed for testing a specific jet engine, knowing the following conditions for a typical test.

- intake air velocity = 700 ft/s
- exhaust gas velocity = 1640 ft/s
- intake cross section area = 10 ft^2
- intake static pressure = 11.4 psia
- intake static temperature = 480 °R
- exhaust gas pressure = 0 psi

estimate a nominal thrust to design for.

5.53 A vertical jet of water leaves a nozzle at a speed of 10 m/s and a diameter of 20 mm. It suspends a plate having a mass of 1.5 kg as indicated in Fig. P5.53. What is the vertical distance h ?

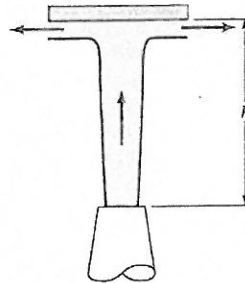

■ Figure P5.53

5.54  A horizontal, circular cross-sectional jet of air having a diameter of 6 in. strikes a conical deflector as shown in Fig. P5.54. A horizontal anchoring force of 5 lb is required to hold the cone in place. Estimate the nozzle flowrate in ft^3/s . The magnitude of the velocity of the air remains constant.

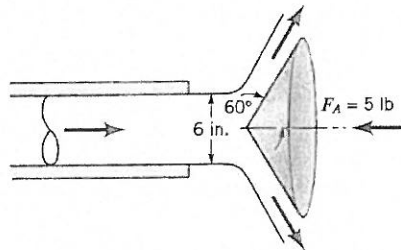

■ Figure P5.54

5.55  A vertical, circular cross-sectional jet of air strikes a conical deflector as indicated in Fig. P5.55. A vertical anchoring force of 0.1 N is required to hold the deflector in place. Determine the mass (kg) of the deflector. The magnitude of velocity of the air remains constant.

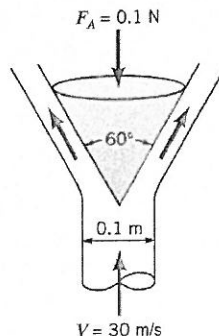

■ Figure P5.55

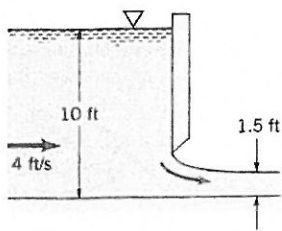

■ Figure P5.62

5.63 Water flows steadily into and out of a tank that sits on frictionless wheels as shown in Fig. P5.63. Determine the diameter D so that the tank remains motionless if $F = 0$.

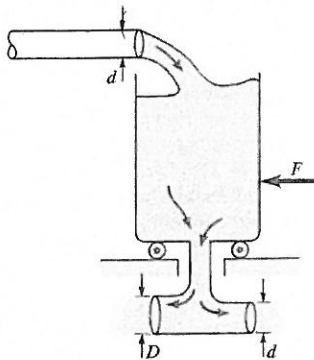

■ Figure P5.63

5.64 The rocket shown in Fig. P5.64, is held stationary by the horizontal force, F_x , and the vertical force, F_z . The velocity and pressure of the exhaust gas are 5000 ft/s and 20 psia at the nozzle exit, which has a cross section area of 60 in.². The exhaust mass flowrate is constant at 21 lbm/s. Determine the value of the restraining force F_x . Assume the exhaust flow is essentially horizontal.

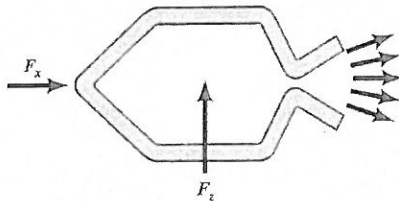

■ Figure P5.64

5.65 A horizontal circular jet of air strikes a stationary flat plate as indicated in Fig. P5.65. The jet velocity is 40 m/s and the jet diameter is 30 mm. If the air velocity magnitude remains constant as the air flows over the plate surface in the directions shown, determine: (a) the magnitude of F_A , the anchoring force required to

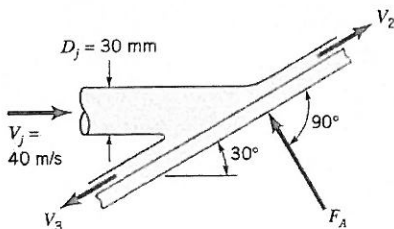

■ Figure P5.65

hold the plate stationary; (b) the fraction of mass flow along the plate surface in each of the two directions shown; (c) the magnitude of F_A , the anchoring force required to allow the plate to move to the right at a constant speed of 10 m/s.

5.66 Air discharges from a 2-in.-diameter nozzle and strikes a curved vane, which is in a vertical plane as shown in Fig. P5.66. A stagnation tube connected to a water U-tube manometer is located in the free air jet. Determine the horizontal component of the force that the air jet exerts on the vane. Neglect the weight of the air and all friction.

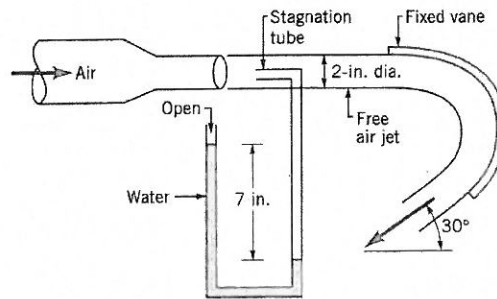

■ Figure P5.66

5.67 Water is sprayed radially outward over 180° as indicated in Fig. P5.67. The jet sheet is in the horizontal plane. If the jet velocity at the nozzle exit is 20 ft/s, determine the direction and magnitude of the resultant horizontal anchoring force required to hold the nozzle in place.

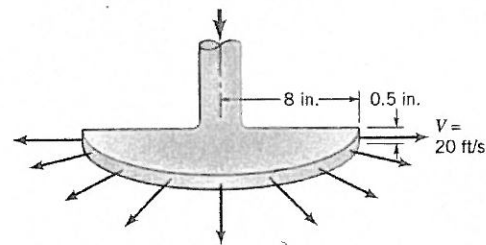

■ Figure P5.67

5.68 A sheet of water of uniform thickness ($h = 0.01$ m) flows from the device shown in Fig. P5.68. The water enters vertically through the inlet pipe and exits horizontally with a speed that varies linearly from 0 to 10 m/s along the 0.2-m length of the slit. Determine the y component of anchoring force necessary to hold this device stationary.

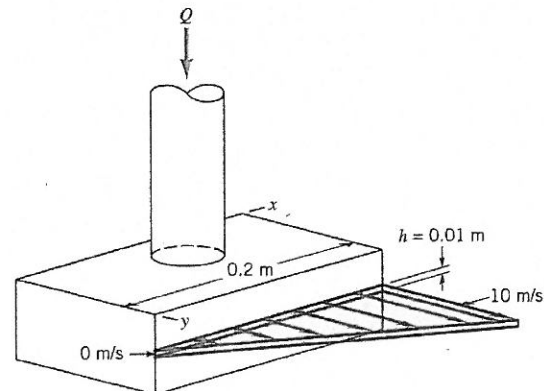

■ Figure P5.68

5.69 The results of a wind tunnel test to determine the drag on a body (see Fig. P5.69) are summarized below. The upstream [section (1)] velocity is uniform at 100 ft/s. The static pressures are given by $p_1 = p_2 = 14.7$ psia. The downstream velocity distribution, which is symmetrical about the centerline, is given by

$$u = 100 - 30\left(1 - \frac{|y|}{3}\right) \quad |y| \leq 3 \text{ ft}$$

$$u = 100 \quad |y| > 3 \text{ ft}$$

where u is the velocity in ft/s and y is the distance on either side of the centerline in feet (see Fig. P5.69). Assume that the body shape does not change in the direction normal to the paper. Calculate the drag force (reaction force in x direction) exerted on the air by the body per unit length normal to the plane of the sketch.

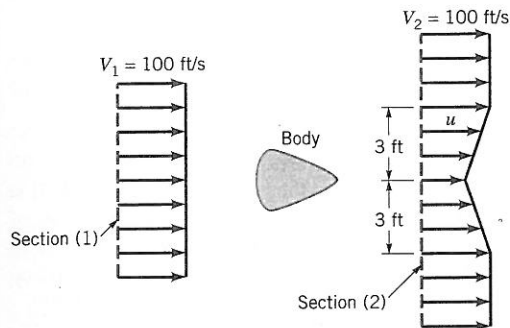

Figure P5.69

5.70 A variable mesh screen produces a linear and axisymmetric velocity profile as indicated in Fig. P5.70 in the airflow through a 2-ft-diameter circular cross-sectional duct. The static pressures upstream and downstream of the screen are 0.2 and 0.15 psi and are uniformly distributed over the flow cross-sectional area. Neglecting the force exerted by the duct wall on the flowing air, calculate the screen drag force.

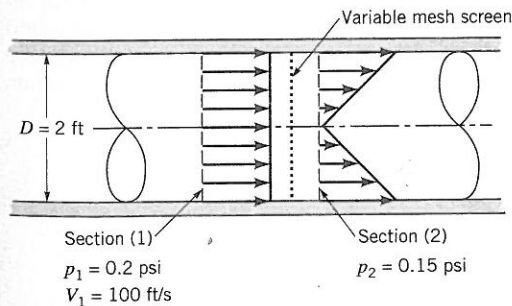

Figure P5.70

5.71 Consider unsteady flow in the constant diameter, horizontal pipe shown in Fig. P5.71. The velocity is uniform throughout the entire pipe, but it is a function of time: $\mathbf{V} = u(t)\mathbf{i}$. Use the x component of the unsteady momentum equation to determine the pressure difference $p_1 - p_2$. Discuss how this result is related to $F_x = ma_x$.

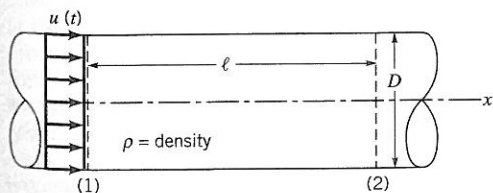

Figure P5.71

5.72 In a laminar pipe flow that is fully developed, the axial velocity profile is parabolic. That is,

$$u = u_c \left[1 - \left(\frac{r}{R} \right)^2 \right]$$

as is illustrated in Fig. P5.72. Compare the axial direction momentum flowrate calculated with the average velocity, \bar{u} , with the axial direction momentum flowrate calculated with the nonuniform velocity distribution taken into account.

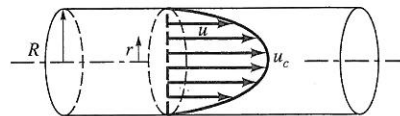

Figure P5.72

†5.73 Water from a garden hose is sprayed against your car to rinse dirt from it. Estimate the force that the water exerts on the car. List all assumptions and show calculations.

5.74 A Pelton wheel vane directs a horizontal, circular cross-sectional jet of water symmetrically as indicated in Fig. P5.74 and Video V5.6. The jet leaves the nozzle with a velocity of 100 ft/s. Determine the x -direction component of anchoring force required to (a) hold the vane stationary, (b) confine the speed of the vane to a value of 10 ft/s to the right. The fluid speed magnitude remains constant along the vane surface.

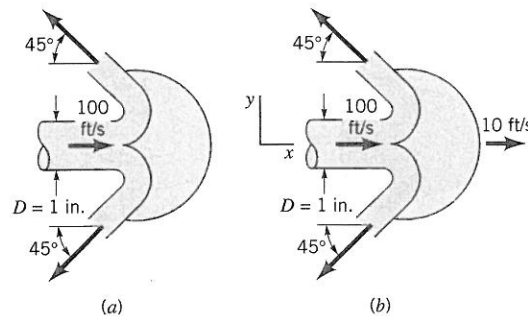

Figure P5.74

5.75 The thrust developed to propel the jet ski shown in Video V9.18 and Fig. P5.75 is a result of water pumped through the vehicle and exiting as a high-speed water jet. For the conditions shown in the figure, what flowrate is needed to produce a 300-lb thrust? Assume the inlet and outlet jets of water are free jets.

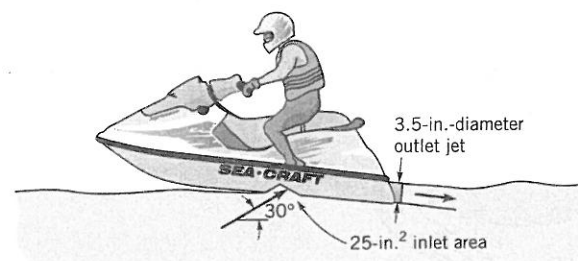
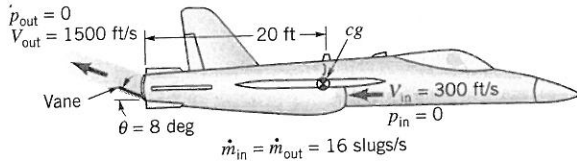

Figure P5.75

5.76 Thrust vector control is a technique that can be used to greatly improve the maneuverability of military fighter aircraft. It consists of using a set of vanes in the exit of a jet engine to deflect the exhaust gases as shown in Fig. P5.76. (a) Determine the pitching moment (the moment tending to rotate the nose of the aircraft



■ Figure P5.76

up) about the aircraft's mass center (cg) for the conditions indicated in the figure. (b) By how much is the thrust (force along the centerline of the aircraft) reduced for the case indicated compared to normal flight when the exhaust is parallel to the centerline?

5.77 The exhaust gas from the rocket shown in Fig. P5.77a leaves the nozzle with a uniform velocity parallel to the x axis. The gas is assumed to be discharged from the nozzle as a free jet. (a) Show that the thrust that is developed is equal to ρAV^2 , where $A = \pi D^2/4$. (b) The exhaust gas from the rocket nozzle shown in Fig. P5.77b is also uniform, but rather than being directed along the x axis, it is directed along rays from point O as indicated. Determine the thrust for this rocket.

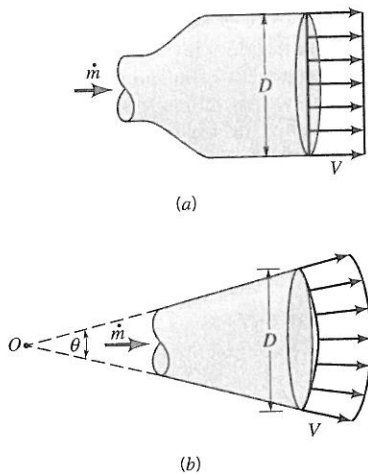

■ Figure P5.77

5.78 (WILEY) (See Fluids in the News article titled "Where the Plume goes," Section 5.2.2.) Air flows into the jet engine shown in Fig. P5.78 at a rate of 9 slugs/s and a speed of 300 ft/s. Upon landing, the engine exhaust exits through the reverse thrust mechanism with a speed of 900 ft/s in the direction indicated. Determine the reverse thrust applied by the engine to the airplane. Assume the inlet and exit pressures are atmospheric and that the mass flowrate of fuel is negligible compared to the air flowrate through the engine.

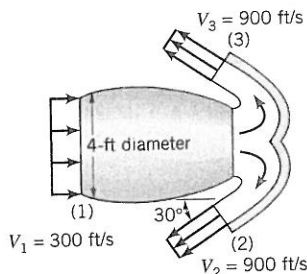

■ Figure P5.78

5.79 (WILEY) (See Fluids in the News article titled "Motorized Surfboard," Section 5.2.2.) The thrust to propel the powered surfboard shown in Fig. P5.79 is a result of water pumped through the board that exits as a high-speed 2.75-in.-diameter jet. Determine

the flowrate and the velocity of the exiting jet if the thrust is to be 300 lb. Neglect the momentum of the water entering the pump.

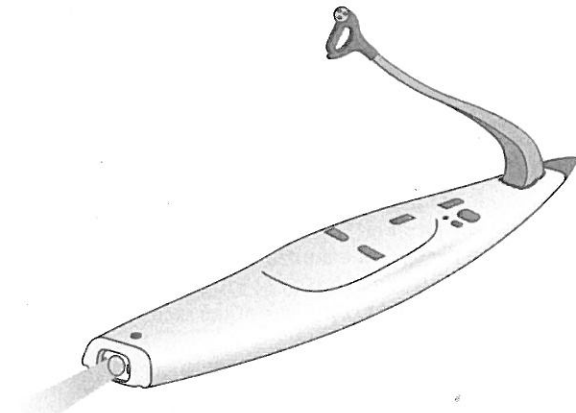

■ Figure P5.79

5.80 (WILEY) (See Fluids in the News article titled "Bow Thrusters," Section 5.2.2.) The bow thruster on the boat shown in Fig. P5.80 is used to turn the boat. The thruster produces a 1-m-diameter jet of water with a velocity of 10 m/s. Determine the force produced by the thruster. Assume that the inlet and outlet pressures are zero and that the momentum of the water entering the thruster is negligible.

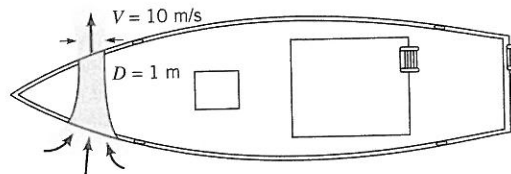

■ Figure P5.80

5.81 Water flows from a two-dimensional open channel and is diverted by an inclined plate as illustrated in Fig. P5.81. When the velocity at section (1) is 10 ft/s, what horizontal force (per unit width) is required to hold the plate in position? At section (1) the pressure distribution is hydrostatic, and the fluid acts as a free jet at section (2). Neglect friction.

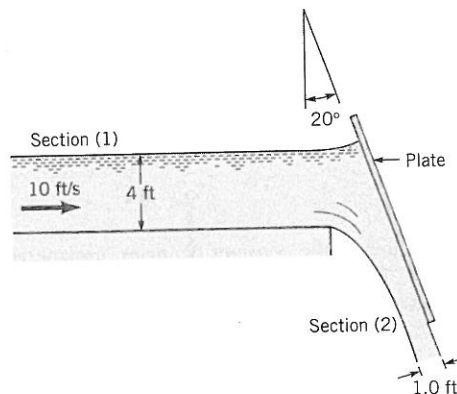

■ Figure P5.81

†5.82 If a valve in a pipe is suddenly closed, a large pressure surge may develop. For example, when the electrically operated shutoff valve in a dishwasher closes quickly, the pipes supplying the dishwasher may rattle or "bang" because of this large pressure pulse. Explain the physical mechanism for this "water hammer" phenomenon. How could this phenomenon be analyzed?

5.83  A snowplow mounted on a truck clears a path 12 ft through heavy wet snow, as shown in Figure P5.83. The snow is 8 in. deep and its density is 10 lbm/ft³. The truck travels at 30 mph. The snow is discharged from the plow at an angle of 45° from the direction of travel and 45° above the horizontal, as shown in Figure P5.83. Estimate the force required to push the plow.

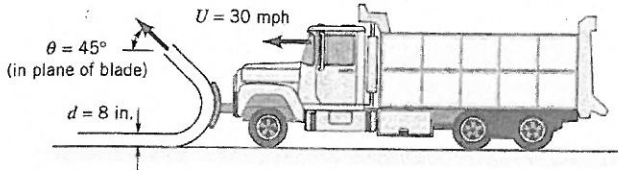

Figure P5.83

Section 5.2.3 Derivation of the Moment-of-Momentum Equation

5.84 Describe a few examples (include photographs/images) of turbines where the force/torque of a flowing fluid leads to rotation of a shaft.

5.85 Describe a few examples (include photographs/images) of pumps where a fluid is forced to move by “blades” mounted on a rotating shaft.

5.86 An incompressible fluid flows outward through a blower as indicated in Fig. P5.86. The shaft torque involved, T_{shaft} , is estimated with the following relationship:

$$T_{\text{shaft}} = \dot{m} r_2 V_{\theta 2}$$

where \dot{m} = mass flowrate through the blower, r_2 = outer radius of blower, and $V_{\theta 2}$ = tangential component of absolute fluid velocity leaving the blower. State the flow conditions that make this formula valid.

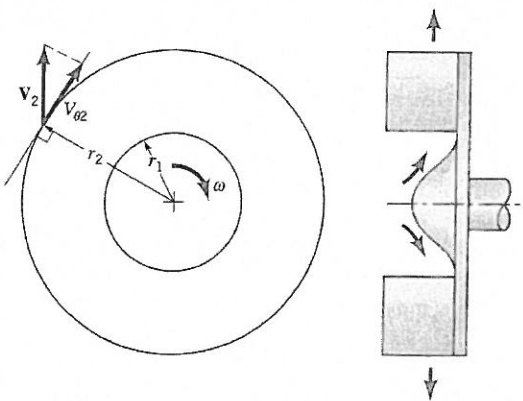



Figure P5.86

Section 5.2.4 Application of the Moment-of-Momentum Equation

5.87  Water enters a rotating lawn sprinkler through its base at the steady rate of 16 gal/min as shown in Fig. P5.87. The exit rate of each of the two nozzles is 0.04 in.², and the flow leaving each nozzle is tangential. The radius from the axis of rotation to the centerline of each nozzle is 8 in. (a) Determine the resisting torque required to hold the sprinkler head stationary. (b) Determine the resisting torque associated with the sprinkler rotating with a constant speed of 500 rev/min. (c) Determine the angular velocity of the sprinkler if no resisting torque is applied.

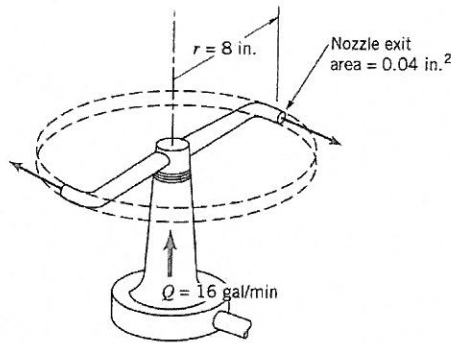



Figure P5.87

5.88  Five liters/s of water enter the rotor shown in Video V5.10 and Fig. P5.88 along the axis of rotation. The cross-sectional area of each of the three nozzle exits normal to the relative velocity is 18 mm². How large is the resisting torque required to hold the rotor stationary? How fast will the rotor spin steadily if the resisting torque is reduced to zero and (a) $\theta = 0^\circ$, (b) $\theta = 30^\circ$, (c) $\theta = 60^\circ$?

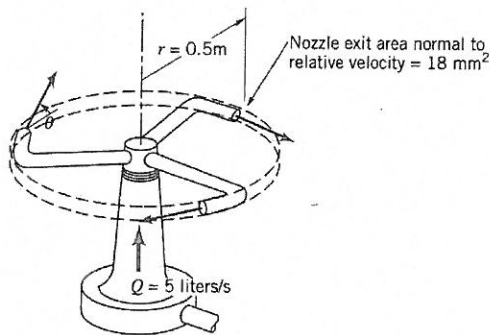

Figure P5.88

5.89 (See Fluids in the News article titled “Tailless Helicopters,” Section 5.2.4.) Shown in Fig. P5.89 is a toy “helicopter” powered

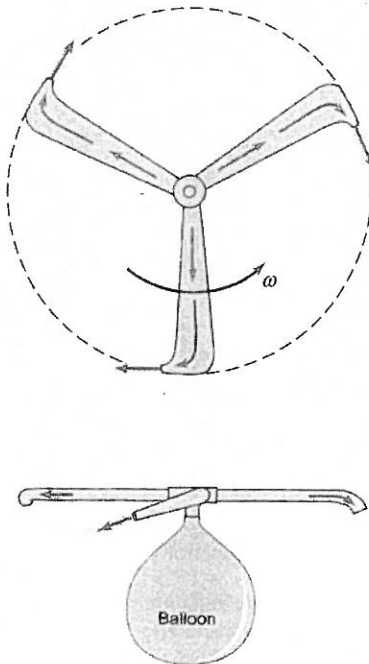

Figure P5.89