

Stretchable Architectures for Next Generation Cellular Networks

S. Lakkavalli(lakkavas@cs.pdx.edu), A. Negi, and S. Singh

Department of Computer Science, Portland State University

Abstract—This paper examines the technique of conserving energy in 3G cellular systems by allowing calls between a mobile and the base station to be forwarded by some other mobile in the cell. This “stretched” call has the benefit of reducing overall energy cost for the call in cases where the calling mobile is NLOS (Non Line of Sight) to the base station but is LOS to the intermediary and the intermediary is LOS to the base station. The main contributions of the paper are twofold: first, we show how this stretched call model can be implemented in UMTS and CDMA2000; second, we show that this stretched call model results in overall energy savings in a cell of between 2x and 7x.

I. INTRODUCTION

Approaches for saving energy at a mobile terminal (MT) in cellular networks include, dynamic transmission power control whereby the MT increases or decreases its transmission power in response to requests received from the base station (BS) [1][2], terminating calls when the interference becomes too high [3], or putting the MT into deep sleep state and waking it up periodically to receive data [4] (as is done in the paging protocol). In this paper we examine a new technique to enable power savings at the MT. The key idea is to split the connection between the MT and BS at an appropriate intermediary (another MT). Therefore, on the reverse link, the MT transmits to the intermediary and the intermediary forwards the call to the BS. In Fig.1, say the mobile **P** needs to set up a call to the base station (BS). However, as shown in Fig.1 (b), the **BS** is NLOS to this mobile. Let us assume that there are other mobiles present in the cell that are idle. Mobile **a** is idle and, as shown in Fig.1(c), it is LOS to the **BS** as well as to the mobile **P**. The call is therefore set up as **P-a-BS**. After some time, **a** is no longer LOS of the BS and the call is handed off to another mobile **d** as shown in Fig.1(d), who is LOS to both **P** and the BS. This *stretched* call model ensures that the total energy used for the call is less than that of a direct call if the intermediaries are selected appropriately. The problems involved in deploying such a stretched call model include intermediary-to-intermediary handoffs, preserving end-to-end encryption, maintaining closed-loop power control at the MT and the intermediary, and efficient algorithms for intermediary selection. In this paper we describe our stretched call model in detail and explain how it fits into CDMA2000, Universal Mobile Telecommunications System (UMTS), and Time Division Synchronous Code Division Multiple Access (UMTS TD-SCDMA) standards for 3G cellular networks. We also show that unlike Opportunity Driven Multiple Access (ODMA), our scheme ensures bounded end-to-end delay enabling voice calls to be carried. Finally, we present results from detailed

simulations of our model and show that energy savings of as much as 2x to 7x is possible in many cases even when using a simple greedy algorithm for intermediary selection.

There are two barriers to implementing the stretched call model in 3G systems: first, the problem of additional hardware complexity in the MTs to enable them to become intermediaries capable of carrying calls, and second, convincing users to allow their MTs to be used as intermediaries when idle. Our work assumes that each MT has *one transmitter and two receivers, which already exist in 3G cellular phones*. Furthermore, the complexity of handoffs between intermediaries is also minimal because, as in the case of repeaters [12], the MT treats the signals from the intermediary as multipath of the BS’s transmission. The second challenge, that of convincing users to allow their MTs to carry calls is more problematic because being an intermediary means that the intermediary is allowing its battery to be used for someone else’s call! We believe that a differential pricing model (where stretched calls are charged at a higher rate than direct calls) with appropriate credits (either as cash or free call minutes) being provided to intermediaries will encourage more users to allow their cell phones to be used as intermediaries when idle. While interesting, in this paper we focus only on the technical problem of implementing stretched calls and leave a discussion of the pricing model to a later paper.

Section II describes other related work in the area. We describe the stretched connection model in section III and in section IV we provide how power control, handoff and security aspects of 3G networks can be handled in our model. We describe our simulator and the experimental design in detail in sections V & VI and present the main results in section VII.

II. RELATED WORK

The idea of using relays in cellular systems is not a new one and has been used to provide coverage in dead spots [5] or to improve capacity in dense areas such as

shopping malls etc. In these systems, repeaters allow MTs to use lower transmit power as well as provide spectrum reuse within the same cell. It is important to note, however, that our scheme differs conceptually from the idea of using repeaters in two ways: first, intermediaries in our model are themselves MTs and thus mobile, and second, our scheme provides overall

energy efficiency in the cell regardless of location of MT, whereas, in the case of repeaters, only mobiles in range of the repeaters can avail themselves of the reduced transmit power opportunity. It is also important to point out that using repeaters incurs an additional infrastructure cost while our scheme has no such capital cost.

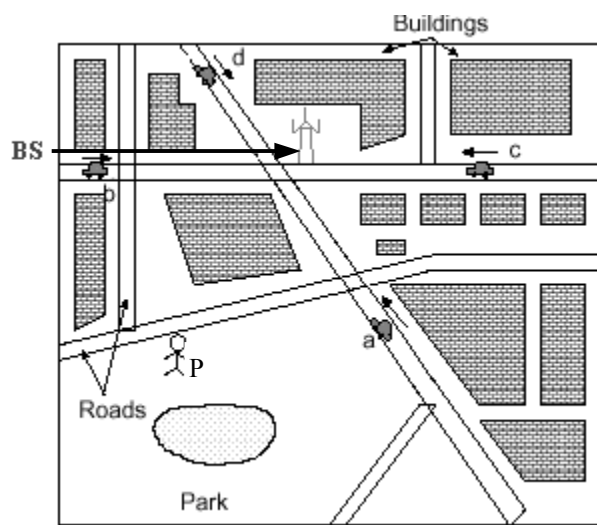

(a) P needs to set up a call

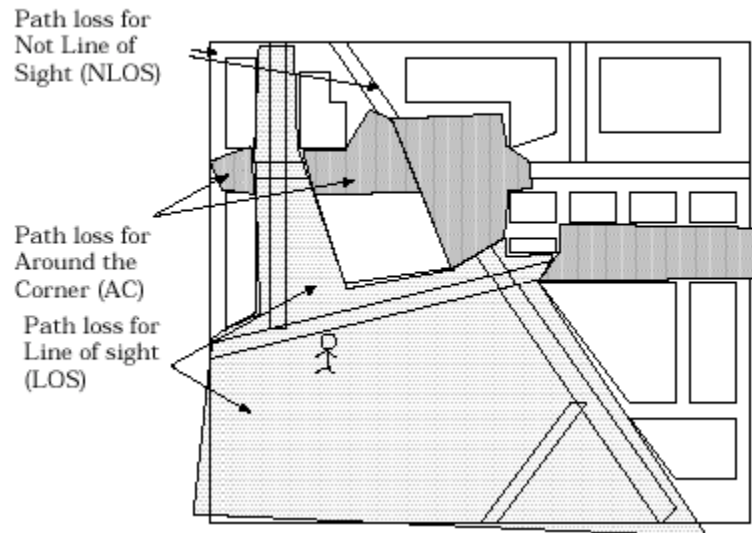

(b) P is NLOS to BS

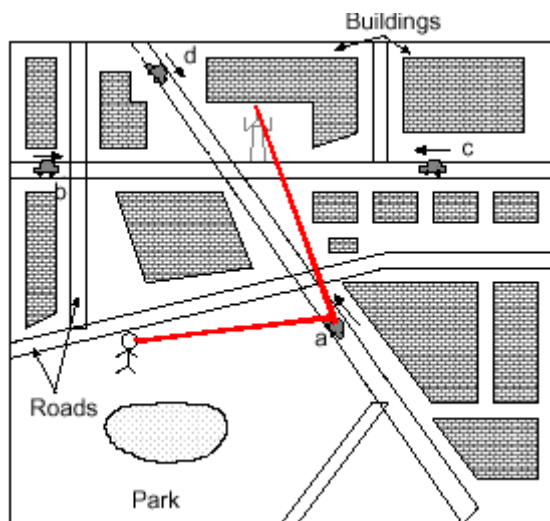

(c) Call setup via intermediary 'a'

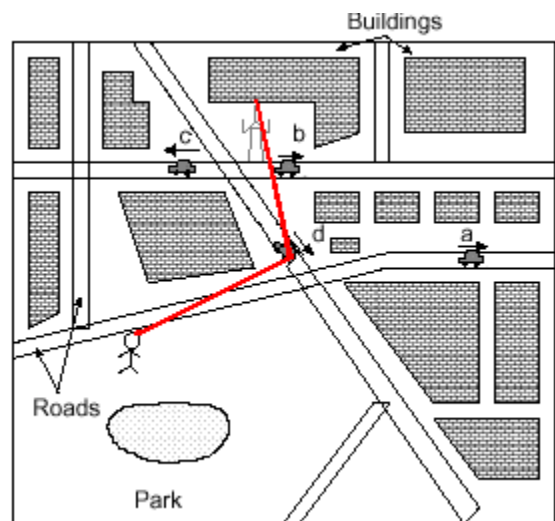

(d) Call handoff from intermediary 'a' to 'd'

Figure 1. Stretched Call Scenario

The 3G standards of Universal Mobile Telecommunications System (UMTS) [6] specify an adhoc mechanism called ODMA for multi-hop connections between the BS and MTs. The intermediaries here are other MTs and each MT maintains a connectivity table of other MTs within range. Each entry in the table contains the identity of the MT, the data rate possible to that MT and the transmit power level required to reach that MT. This information is refreshed via the broadcast of periodic probe packets, and so every MT regularly updates its routing table. In our case, where power conservation is the goal at the MT, the overhead of periodic updates and additional processing required for maintenance of the routing tables will decrease the already depleting battery resources at the MT. For routing mechanism, we use the repeater principle of passive handoff, where the MT thinks that signals from the intermediary are like multipath from the BS. So here, the MT need not know the identity of the intermediary, and this saves the overhead of routing table maintenance at the MT. Therefore, our two-hop relaying mechanism is different from the adhoc network mechanism like ODMA. The responsibility of choosing the intermediaries is with the BS, which has a database of all the nodes in its domain. The advantage of letting the BS choose the intermediary is that it has knowledge of the speed and direction of motion of both the MT and the intermediary, based upon which the BS can optimize and select the best intermediary (in terms of low energy as well as stability to minimize the need for handoffs). Another important advantage of our stretched connection model is that, if a stretched connection can be maintained for the duration of the call, the delay is not variable as in the case of ODMA because we only interject one node between the MT and the BS. In ODMA, on the other hand, the number of intermediaries can vary, and therefore the end-to-end delay is variable making it unsuitable for real time applications like voice and video conferencing.

III. OVERVIEW OF STRETCHED CONNECTION MODEL

A stretched connection has an intermediary, which carries the call from mobile to BS and vice-versa. The connection between the mobile and the intermediary is called as Lower Arm (LA) and the connection between the Intermediary and BS is called as Upper Arm (UA). The connection between mobile and BS is called a Direct Connection. An intermediary can be stationary or mobile. Mobile phones with sufficient battery power or a car phone are two examples of intermediaries. The reverse link as well as the forward link can be split at the intermediary or we can have an asymmetric case where only the reverse link is split at the intermediary. The intermediary in our system is assumed to have *only one transmitter* and therefore it has to time multiplex its transmission between the two arms of the stretched connection. To increase the usability of the intermediary, it is *assumed to have dual receivers*, so that it can receive transmissions from both the mobile and the BS simultaneously.

A. State Machine

The node has five call states – IDLE, REQUESTED, DIRECT, STRETCHED, CARRYING as shown in Fig. 2. The node is in IDLE state when it is not calling. It goes to REQUESTED state when a call initiation has been notified to the BS (BS). The BS will assign an intermediary to the Mobile Terminal (MT), in which case it will go to STRETCHED state. If the BS was not able to assign an intermediary it goes to DIRECT state. The node can toggle between DIRECT and STRETCHED states within the duration of a call. Once the call is terminated, it goes back to IDLE state. If the node is IDLE and the BS requests it to carry a call, it goes to CARRYING state. From CARRYING state, the node can transition to either IDLE state or to REQUESTED state, if the intermediary itself wants to initiate a call.

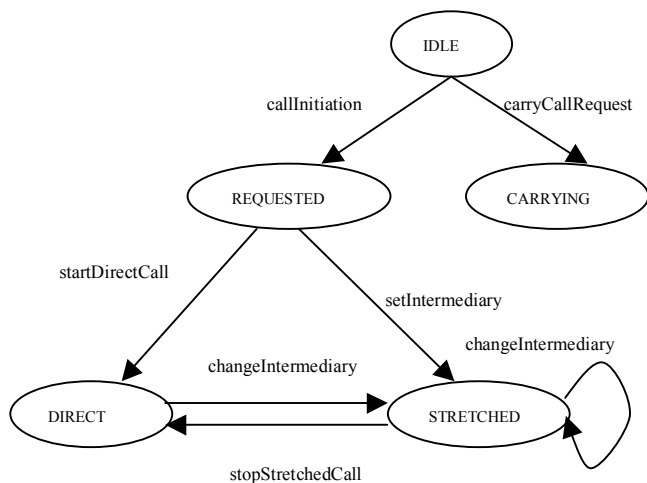

Figure 2. Finite State Automata of a Mobile

In Fig. 3, we have the BS's view of mobile states. It maintains the current state of the MT, both its call state and mobility state. The BS maintains two additional call states for the node. They are CHANGING-INTERMEDIARY and CHECKING-INTERMEDIARY states. CHANGING-INTERMEDIARY state of the node is maintained between intermediary handoffs. This state is required to represent the state when the BS is finding a suitable intermediary for the MT. The CHECKING-INTERMEDIARY state is used for the possible intermediary when it is being sent a request to carry. The mobile has two mobility states – MOVING and STATIONARY. The call states and mobility states are updated to the BS, whenever they change.

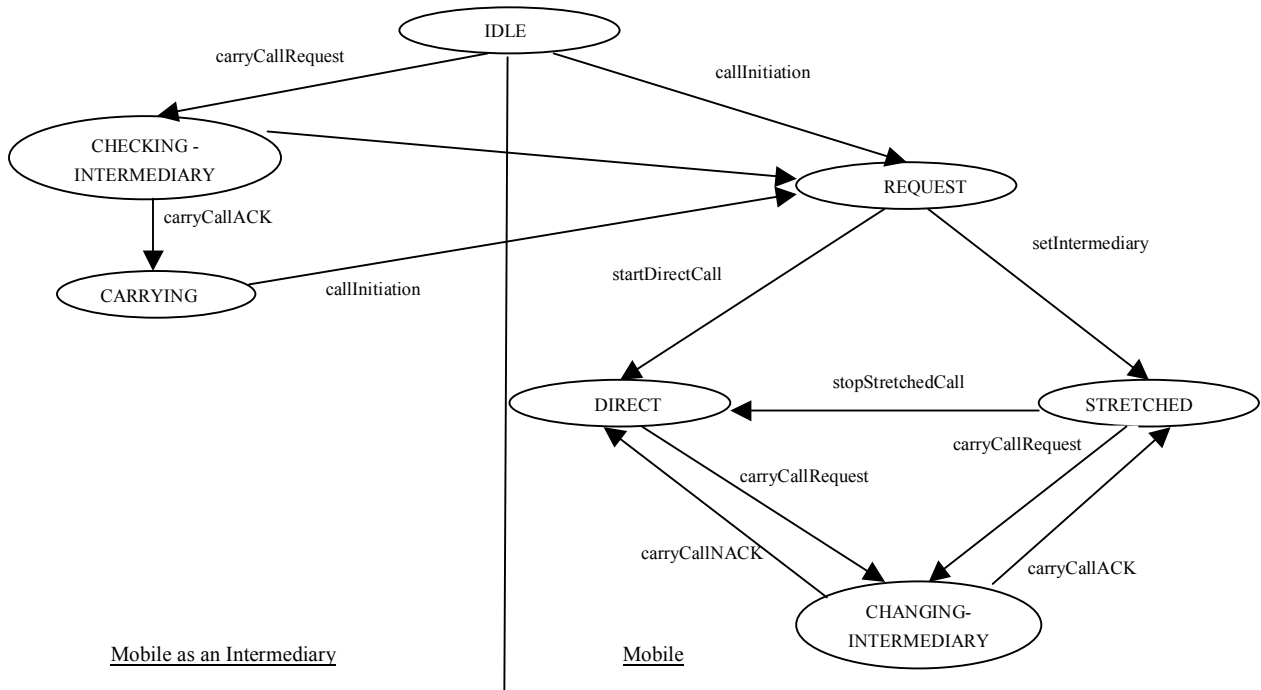

Figure 3. Finite State Automata of a Mobile in the Base station

B. Finding An Intermediary

Since the number of hops in the radio link is increased by just one, the BS can continue to control the handoffs between intermediaries. The BS can frequently broadcast the forward link orthogonal codes and the reverse link phase offsets of the long PN code in case of cdma2000 or the scrambling code in case of UMTS Radio Terrestrial Access (UTRA)¹.

The mobiles in IDLE mode on reception of these broadcasts can adjust their PN generator hardware and their demodulators to synchronize with the reverse and forward link traffic channels. It is assumed here that the BS transmits required information in the broadcast channel to enable the intermediaries to synchronize with the mobile's traffic channel.

The intermediaries maintain an active list of mobiles in DIRECT state, whose signal SNR exceeds the threshold setup for the connection. The intermediaries use the same mechanism of soft handoff to maintain active, candidate, neighbor and remaining sets. But here, they maintain these sets containing mobiles wishing to get their calls carried, instead of the BS'. The intermediaries repeatedly report the active list members in their dedicated control channels to the BS. The BS,

which will receive similar information from IDLE mobiles in the vicinity of the DIRECT state mobile, will run optimizations to select the best intermediary. Algorithms to determine the best intermediary are still under research. In this paper we use a simple *greedy* approach to find the appropriate intermediary – the intermediary that minimizes the total power for the connection is selected.

It is important to note that the upper and lower arms of the stretched connection require different frequencies, so as to prevent the transmitter at the intermediary from overwhelming its own receiver. Though two frequencies are required, which might seem to double the required bandwidth and therefore half the capacity, lower transmitting powers of the MT and intermediary decrease intracell and intercell interference, which increases the capacity of the cell. This topic is under research.

IV. 3G STANDARDS RELATED ISSUES

So far, we have seen that intermediary-to-intermediary handoff can take place using the soft handoff mechanism that is part of 3G specifications. We have also seen that single transmitter and dual receivers required for a stretched connection are already a part of 3G mobiles. As in ODMA, it can be assumed that uplink spreading and modulation can be made similar to downlink spreading and modulation, so that minimal hardware changes are required at the intermediary. In this section, we describe how delay, power control, handoff and security aspects of 3G networks can be adopted in our model. Before we discuss the above issues, however, we need to observe that the

¹ In cdma2000, the phase offsets are determined using Equipment Serial Number (ESN) number of the mobile. To generate the phase offset, the ESN number is required. Therefore, this has a security risk. But in UTRA, the orthogonal codes and the scrambling codes do not have any security use and therefore, they can be broadcasted.

intermediary can operate in one of two modes when carrying a call – *translating and non-translating* modes.

In translating mode, the whole frame has to be received and regenerated, while in non-translating mode, the intermediary has to deal only with demodulation, despreading and decoding the power control bits from every Power Control Group (PCG). The power control mechanism used for both the modes is similar. In the translating mode, the intermediary receives the signal from any arm, say for example the upper arm in the case of forward link, demodulates with the carrier of the receiving arm, reads the power control bit from each slot – PCG so that it can modify its transmit power in that arm, de-spreads, de-scrambles, de-interleaves and decodes the data. It calculates the Frame Error Rate (FER) and compares it with the one in the frame so that it can modify the required value of Signal to Noise Ratio (E_b/N_0). Also, for non-real time data, the Radio Link Protocol (RLP) in the link layer uses this information for controlling retransmissions. While transmitting the frame, the intermediary recalculates the FER, appends it to the data, encodes, interleaves, scrambles, spreads and then modulates the frame with the carrier of the other arm. It also punctures the power control bit in every PCG to control future transmissions from that arm. Similar is the case for the reverse link.

In the non-translating mode, the intermediary has to only process the PCG in a frame before forwarding it. There are 15 PCG in a UTRA frame [2] and 16 PCG in cdma2000 [7] and depending on the frame duration, the duration of the PCG can vary between 0.667ms to 1.25ms. For the forward link for example, for each slot, the intermediary only extracts the power control bit the BS sends to it and inserts its own power control bits for the mobile. So, the intermediary has to save just a PCG before forwarding it. Similar is the case for the reverse link. But, to verify the FER, the intermediary has to still save the whole frame.

If it is a translating intermediary, due to the regeneration time, the regeneration will include interleaving and de-interleaving delays and processing delays. Shorter the frame, lesser is the delay. So, if TD-SCDMA is used, where the frame duration is 5ms, the delay is minimized.

The security mechanisms in cdma2000 and UMTS differ. Voice privacy is provided in cdma2000 in the physical layer, whereas data privacy is in the MAC layer. Because voice privacy is implemented in the physical layer in cdma2000, and the stretched model in translating mode needs do the entire physical layer processing, the stretched model cannot be used for voice. Data calls, however, can use the stretched model. On the other hand, since voice as well as data privacy is implemented at the MAC in UMTS, the stretched model can be used for both types of calls without affecting privacy.

V. SIMULATOR DESIGN

We have developed a very detailed standards-compliant cell-site discrete event simulator to evaluate the stretched connection model. The propagation model implemented is a recursive model specified in [10] and explained in [11]. The arrival of calls at the BS is modeled as a Poisson distribution, with inter-arrival duration modeled as an exponential distribution. The node mobility is modeled as a Gaussian distribution. The mean velocity is a variable factor with the standard deviation equal to 10% of the mean. The mobility is assumed as a Gaussian distribution because most of the vehicles travel at the mean velocity, with few traveling at higher or lower velocities.

There are two types of events – external events and internal events. External events dictate the time of call initiation, termination and node mobility. These are controlled using the call and mobility probabilistic models used in the simulator. In response to these external events, internal events are generated. These internal events occur within the duration of a call. External events have higher priority over internal events.

The simulator creates a grid-based map with user-specified grid sizes. The user can add obstructions to simulate buildings as in a Manhattan environment. The user also specifies location of roads and intersections. Directional probabilities are assigned to each of the four roads originating from the Intersection. A mean velocity is assigned to each road with a standard deviation of 10% of the mean velocity. When a MT reaches an intersection, the direction and velocity are assigned using the above probabilities. The BS can be located anywhere in the map and this is also a user specified parameter. The size of the map is limited by the maximum allowable path loss for the terrain that the map is trying to simulate. For example, for speech in a pedestrian environment like the Manhattan model, the maximum reverse link path loss is 148.4dB [6].

Path loss between any two points in the terrain is calculated and stored for repetitive experiments. For improved accuracy, we use the inverse square weighted interpolation formula. This formula takes the path loss between centers of the current and next grids of both nodes. Then, by calculating the offsets of the distance that both the nodes have moved (zero in case of BS), we can find out the exact path loss.

VI. EXPERIMENTAL SETUP

The size of a grid is fixed for our simulations at 20meters. The link budget values are taken from [10] for a pedestrian terrain. The *factors* considered here are *numbers of nodes*, *call rate* and *cell antenna gain*. The numbers of nodes is varied from 5 to 30 in steps of 5. The call rate is 1 and 2 calls per hour per MT. The call duration has a mean value of 120seconds. The antenna gain was set at either 6dB or 10dB. The simulations are

done for a single cell with only one BS. Two sets of experiments were conducted. In the first, the BS was kept in the center of the cell and in the second case, the BS was kept in the corner of the cell. The mean node speed is 1.5meters/sec. The BS finds the best intermediary whenever the call state changes or when a MT (either the MT itself or its intermediary) changes grid location.

For the link budget of the lower arm of the reverse link, there is no BS gain because it involves communication between mobiles and the mobiles are assumed to have isotropic antennas. Similarly, for the forward link in the lower arm of the stretched connection, there is no BS gain. For the upper arm of the reverse link the link budget is similar to a direct connection. The mobile antenna gain is assumed to be zero for all cases.

VII. RESULTS AND DISCUSSION

For an evaluation of our stretched call model, we used the following metrics:

- Total energy used during a run of 1000s (*direct calls* between MT and BS or *stretched calls* where the intermediary is selected using the greedy algorithm described in section II.B). We also show the energy used per node.
- Number of handoffs between intermediaries.
- Percentage of time the calls were stretched as a function of number of MTs.

In the remainder of this section, we discuss only the results obtained using a 10dB antenna gain. The results for 6dB show a similar trend and have been left out for reasons of space.

The first set of figures shows results for the case when the BS was located in the center of the cell. Fig. 4 shows the total system energy as a function of the number of nodes in the cell for two different call rates. Fig. 5 shows the same information on a per node basis. As can be easily seen, higher call rates consumes more energy. However irrespective of call rates the stretched model consumes less energy as compared with the direct model. For a call rate of 1, the savings are greater than 50%, while for a call rate of 2 the savings vary from 3x to more than 7x. Also the spread in confidence interval is less for stretched system.

Fig 6 shows the number of handoffs during periods of length 1000s. As we can see, the number of handoffs is higher at higher call rates. This is because at higher call rates, more MTs are actively placing calls and thus, if they are serving as intermediaries when a new call request arrives, the carried call will need to be handed off to another idle MT. This figure shows the handoff rate for the case when the BS is at the center of the cell. We observe similar numbers for the case when the BS is in a corner of the cell.

We ran similar experiments when the BS was in a corner of the cell (this is a realistic scenario where the BS covers the cell using sectorized antennas). Fig 7 shows the direct and stretched mode energies. On comparing with Fig. 4 when the BS was at center of the cell, it can be seen that for higher number of nodes, more energy is being spent. This is because the distance to the BS has increased thus directly impacting the energy of the direct or stretched call. In terms of savings, we see a *energy savings of up to 4x* when using the stretched call model.

In Fig 8 for BS at center, the percentage of time spent by a node with stretched connections increases with the number of nodes. Similar is the case for BS at corner scenario. We see that as the number of nodes increase, the percentage of carrying time of a node does not increase as much as the stretched time. Thus the overhead on the intermediaries is minimal.

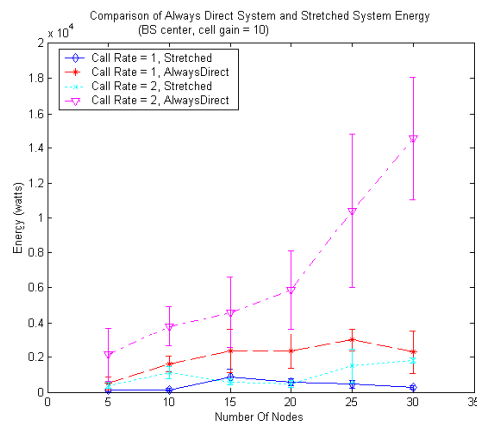

Figure 4. Total system energy for always-direct system and stretched system with BS at center

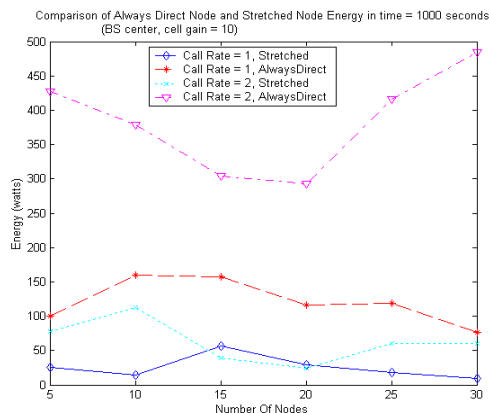

Figure 5. Per node energy for always direct system and stretched system with BS at center

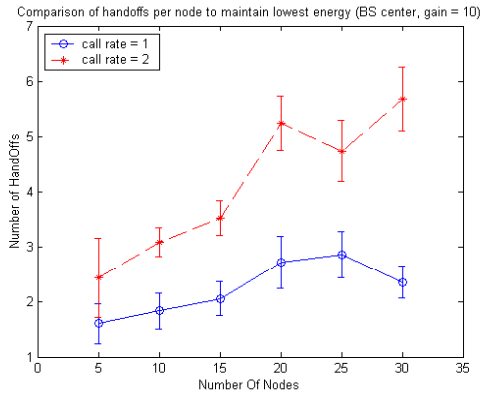

Figure 6. Number of handoffs required per node with BS at center

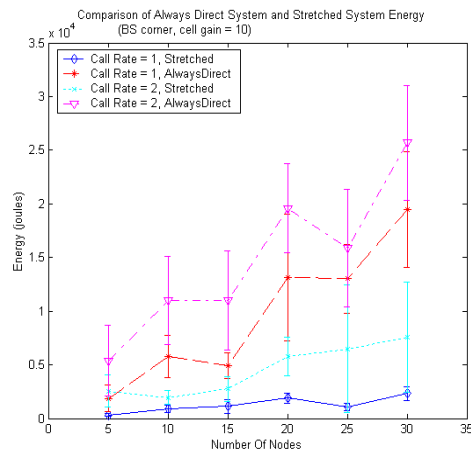

Figure 7. Total system energy for always-direct system and stretched system with BS at corner

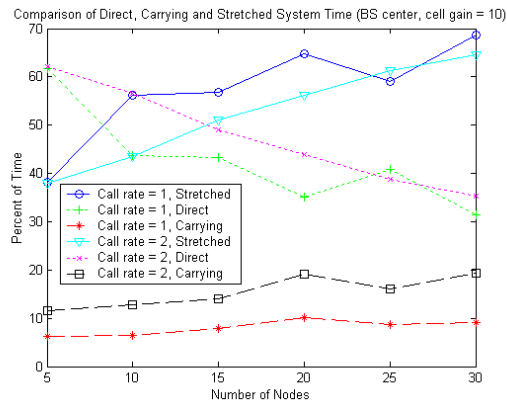

Figure 8. Percentage of direct, stretched, carrying duration with BS at center

VIII. CONCLUSIONS

In this paper we presented a stretched call model for 3G systems in which high energy direct calls between mobiles and BS could be split at another mobile in order to reduce the overall energy used for the call. We described how this call model could be implemented in UMTS and CDMA2000 standards and guidelines for selecting different implementation parameters. Finally, we evaluated the stretched call model in a simulator to determine the extent of energy savings obtainable. As we show, energy savings of up to 7 times are possible! This huge energy reduction is a good reason for further exploration of the stretched call idea in next generation cellular systems.

IX. REFERENCES

- [1] Jhong Sam Lee and Leonard E. Miller, *CDMA Systems Engineering Handbook*, Artech House, Boston, 1998.
- [2] Vijay K. Garg, *Wireless Network Evolution, 2G to 3G*, Prentice Hall PTR, NJ, 2002.
- [3] John M. Rulnick and Nicholas Bambos, "Mobile power management for wireless communication networks", *Wireless Networks*, vol. 3, pp. 3-14, 1997.
- [4] Tajana Simunic, "Dynamic management of power consumption", *Power Aware Computing*, Edited by R. Graybill, R. Melhem, Kluwer Academic Publishers, 2002.
- [5] George N. Aggelou and Rahim Tafazolli, "On the relaying capacity of next-generation GSM cellular networks", *IEEE Personal Communications*, pp. 40-47, Feb 2001.
- [6] Concept evaluation, Universal Mobile Telecommunications System (UMTS), *UMTS Terrestrial Radio Access (UTRA), UMTS 30.06 version 3.0.0*, 1997.
- [7] Physical Layer Standard for cdma2000 Spread Spectrum Systems, Release A, *3rd Generation Partnership Project 2 (3GPP2), 3GPP2 C.S0002-A*, 2001.
- [8] Services and service capabilities, *Universal Mobile Telecommunications System (UMTS), 3GPP TS 22.105 version 5.1.0 Release 5*, 2002.
- [9] M.Haardt, A.Klein, R.Koehn, S. Oestreich, M. Purat, V. Sommer and T. Ulrich, "The TD-CDMA based UTRA TDD mode," *IEEE Journal on Selected Areas in Communications*, vol. 18, pp. 1375-1386, Aug. 2000.
- [10] Selection Procedures for the choice of Radio Transmission Technologies of the UMTS, *Universal Mobile Telecommunications System (UMTS), UMTS, 30.03 version 3.1.0, TR 101 112*, 1997.
- [11] Jan-Erik Berg, "A recursive method for street microcell path loss calculations", *PIMRC*, 1995.
- [12] Repeater Technologies, Inc., <http://www.repeaters.com>, July 10, 2002.