

Digital Multimeter Guide
Mastech M9803R

Version 2008-Jan-1

Dept. of Electrical & Computer Engineering
Portland State University

Copyright © 2008 Portland State University

1 – Basic Information

This guide provides basic instructions for operating the Mastech M9803R Bench Digital Multimeter. The M9803R provides these features:

- Multiple measurement functions:
DC & AC voltage, DC & AC current,
resistance, audible continuity test,
capacitance, frequency, diode test
- True RMS capability
- 4 ½ digit backlit LCD display with 42 segment bar graph
- Auto and Manual Range with data hold
- RS232C computer interface

2 – Instrument Front Panel

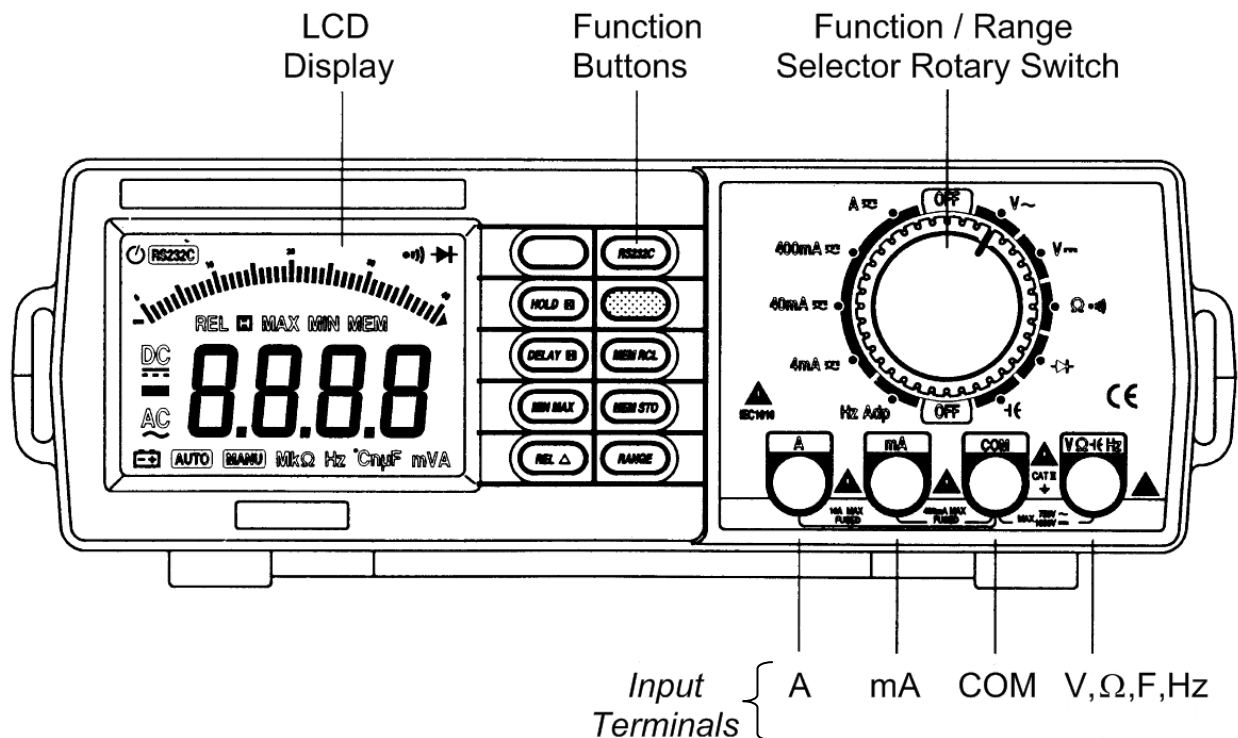

Figure 1: Mastech M9803R front panel
Copyright © Precision Mastech Enterprises Co.

LCD Panel

The LCD shows the measured value as numbers in the center of the display. In addition, a multi-segment bar graph gives an analog representation of the value. At the bottom of the panel is a row of annunciators that indicate the range mode, measurement unit (V, A, Ω , F, Hz), and multiplier (n, μ , m, k, M).

Power Switch

This switch controls the AC line input to the multimeter. It is located at the rear of the multimeter case.

Function / Range Selector Rotary Switch

The rotary switch selects which measurement function to perform. For DC and AC current measurements, it also sets the range¹.

The multimeter is turned off by rotating the switch to the OFF position. When the switch is in any other position, the multimeter is turned on.

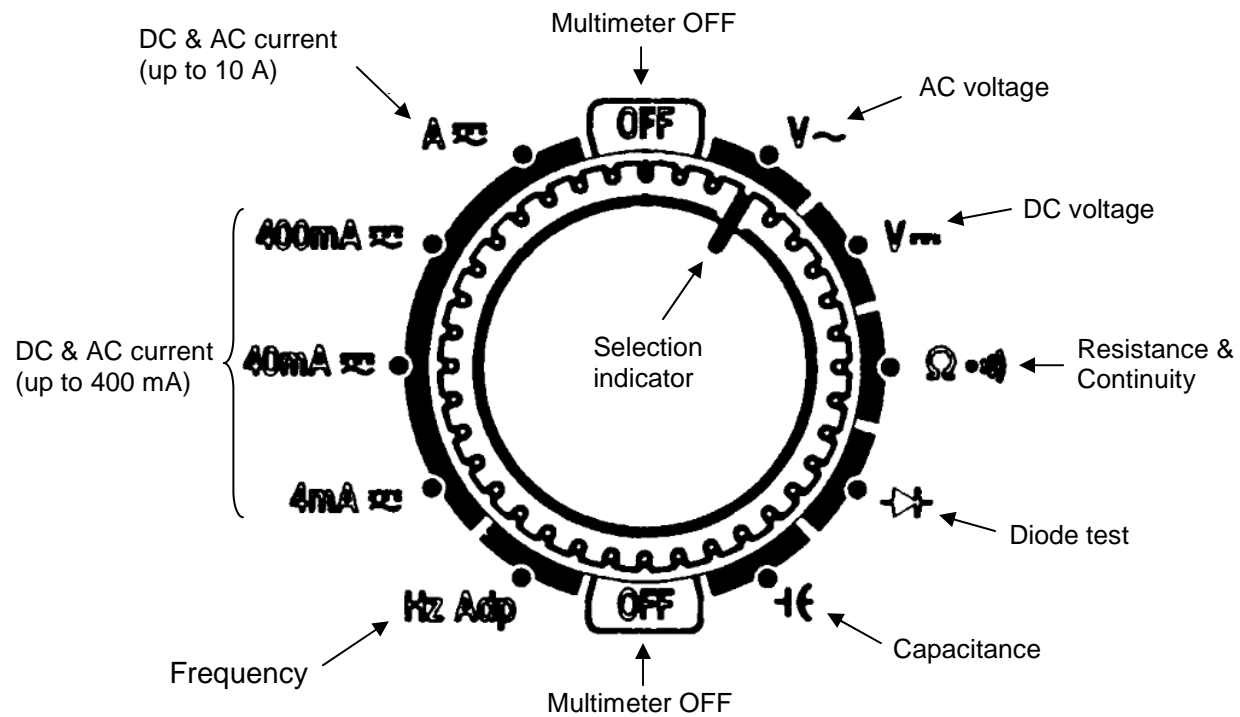





Figure 2: Close-up view of the rotary switch
 Copyright © Precision Mastech Enterprises Co.

¹ Use a range that is just large enough to accommodate the maximum DC or AC current to be measured. As an example, if the actual current is 15 mA, then the 40 mA range is optimal. The 4 mA range is too small, while the 400 mA range is too big. Note that 400 mA will work, but the 40 mA range has better resolution.

Function Buttons

These buttons activate additional multimeter functions. Some often used buttons are:

-  BACKLIGHT – illuminates the LCD display.
-  FUNCTION SELECTOR
 - When the rotary switch is set for Resistance & Continuity, pressing this button toggles between Resistance mode and Continuity mode.
 - When the rotary switch is set for DC and AC current (A), pressing this button toggles between DC mode and AC mode.
 - When the rotary switch is set for DC and AC current (mA), pressing this button toggles between DC mode and AC mode.
-  RANGE – allows manual selection of the measurement range

Differences among Auto Range, Manual Range, and Fixed Range modes

In Auto Range mode, the multimeter automatically chooses the appropriate range for measuring and displaying the data. In Manual Range mode, the user can step through different ranges by pushing the RANGE button. In Fixed Range mode, the range is set by the position of the rotary switch, so the RANGE button has no effect.

Function	Auto	Manual	Fixed
DC Voltage	√	√	
AC Voltage	√	√	
DC & AC Current (A)			√
DC & AC Current (mA)			√
Resistance	√	√	
Continuity			√
Capacitance	√	√	
Frequency	√		
Diode			√

Table 1: Available range modes for each measurement function

- Pressing the RANGE button selects the Manual Range mode. The “AUTO” annunciator will turn off, and the “MANU” annunciator will turn on.
- Each subsequent press of the RANGE button will change the range and update the display.
- Pressing the RANGE button for longer than one second will exit the Manual Range mode and revert back to Auto Range mode. The “MANU” annunciator will turn off, and the “AUTO” annunciator will turn back on.

Warning

When measuring current, always start at the highest range first and check the measured value. If more resolution is needed, then gradually step down to lower ranges. Failure to follow this procedure can lead to excessive current at the mA or A input terminals of the multimeter and may blow the internal fuse.

Input Terminals

External test leads are connected to the input terminals of the multimeter.

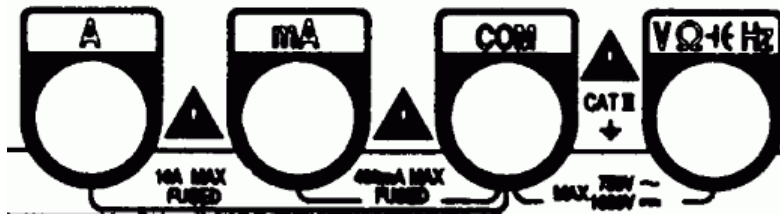

Figure 3: Close-up view of the input terminals
Copyright © Precision Mastech Enterprises Co.

- **VΩ|Hz** – Positive input terminal for all functions except current measurements
- **COM** – Negative (ground) input terminal for all functions
- **A** – Positive input terminal for both DC and AC current measurements up to 10 A
- **mA** – Positive input terminal for both DC and AC current measurements up to 400 mA

3 – Test Leads

Test leads are insulated wires that connect the circuit or component being tested to the multimeter’s input terminals. Two leads are required for all measurements. By convention, one lead is color-coded red (positive input), while the other is color-coded black (negative or ground input).

One end of the test lead is plugged into an input terminal on the multimeter. The other end can be one of a variety of test connectors. Popular choices include straight test probes, alligator clips, mini-grabbers, and spade lugs.

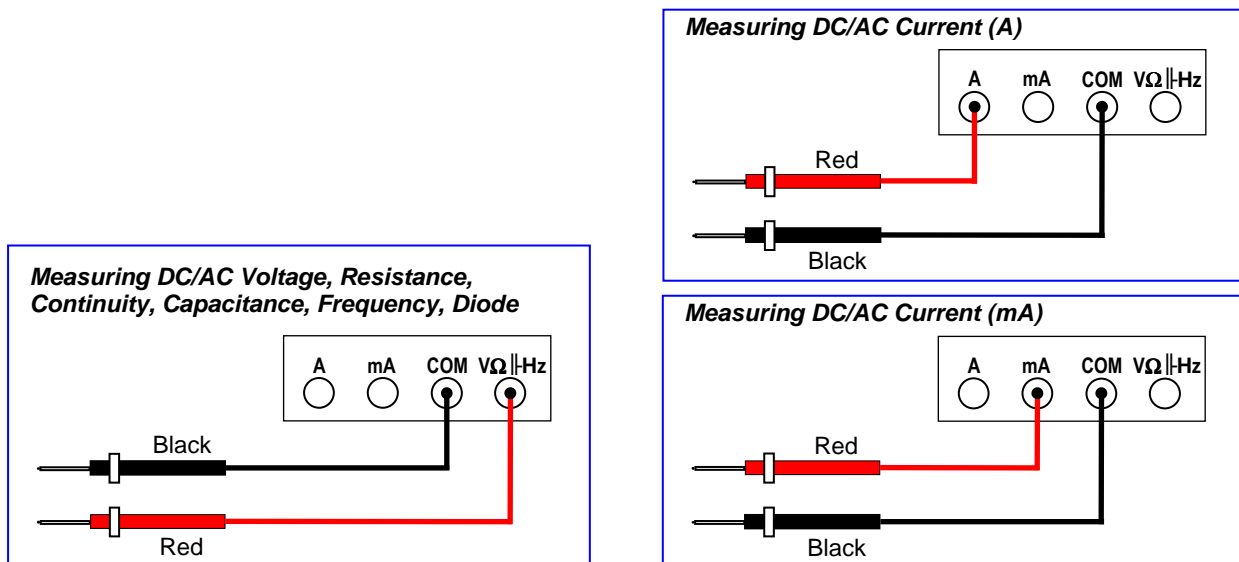

Figure 4: Standard test lead connections for various measurements

4 – Measurement Procedures

Measuring DC Voltage (V)

1. Attach test leads to the input terminals.
Black → COM , Red → V Ω ||Hz
2. Turn the rotary switch to: V $\overline{\text{—}}$
3. Choose either Auto Range (default) or Manual Range.
4. Connect the test leads in parallel across the test circuit.
Red probe tip → positive side of circuit
Black probe tip → negative side of circuit
5. Read the measured voltage.

Note: If the positions of the probe tips are swapped, the measured value will have a negative sign.

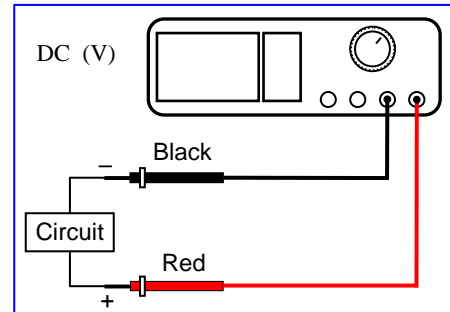

Measuring AC Voltage (V)

1. Attach test leads to the input terminals.
Black → COM , Red → V Ω ||Hz
2. Turn the rotary switch to: V \sim
3. Choose either Auto Range (default) or Manual Range.
4. Connect the test leads in parallel across the test circuit.
5. Read the measured voltage.

Note: The M9803R displays the RMS (Root Mean Square) magnitude of the AC waveform.

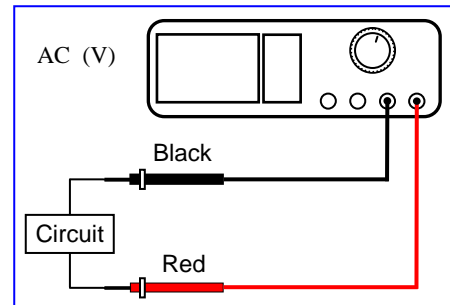

Measuring DC & AC Current (up to 10 A)

1. Attach test leads to the input terminals.
Black → COM , Red → A
2. Turn the rotary switch to: A $\overline{\text{—}}$
3. Use the FUNCTION SELECTOR button to set whether DC or AC current will be measured.
4. Turn off power to the test circuit and then connect the test leads in series with the circuit branch to be measured.
5. Turn on power to the circuit and read the measured current.

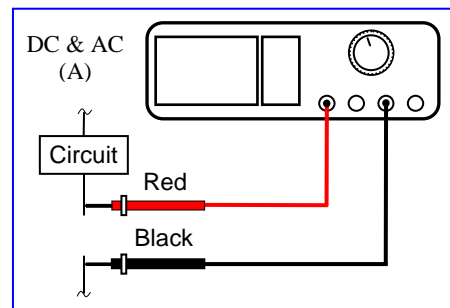

Measuring DC & AC Current (up to 400 mA)

1. Attach test leads to the input terminals.
Black → COM , Red → mA
2. Initially, turn the rotary switch to: 400mA \approx
3. Use the FUNCTION SELECTOR button to set whether DC or AC current will be measured.
4. Turn off power to the test circuit and connect the test leads in series with the circuit branch to be measured.
5. Turn on power to the circuit and read the measured current.

Note: If the value does not have enough resolution, then use the rotary switch to progressively lower the range setting to either 40mA or 4mA.

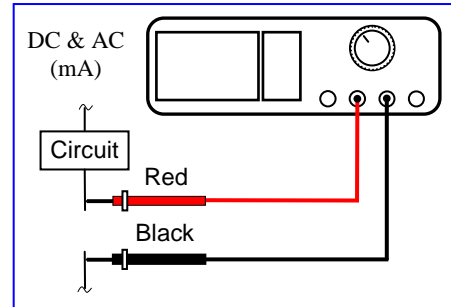

Measuring Resistance (Ω)

1. Attach test leads to the input terminals.
Black → COM , Red → $V\Omega$ || Hz
2. Turn the rotary switch to: Ω \gg
3. Choose either Auto Range (default) or Manual Range.
4. Turn off any power to the test device. Connect the test leads across the resistor.
5. Read the measured resistance.

Note: Measurement accuracy can be improved by using REL mode (*Refer to full Users Manual*).

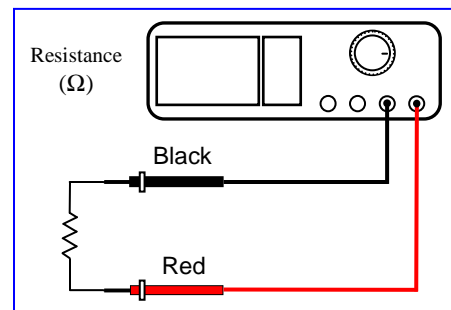

Measuring Capacitance (F)

1. Attach test leads to the input terminals.
Black → COM , Red → $V\Omega$ || Hz
2. Turn the rotary switch to: F
3. Choose either Auto Range (default) or Manual Range.
4. Turn off any power to the test device and discharge the capacitor².
5. Connect the test leads across the capacitor. If the capacitor is polarized, be sure to follow the polarity markings.
6. Read the measured capacitance.

Note: Measurement accuracy can be improved by using REL mode (*Refer to full Users Manual*).

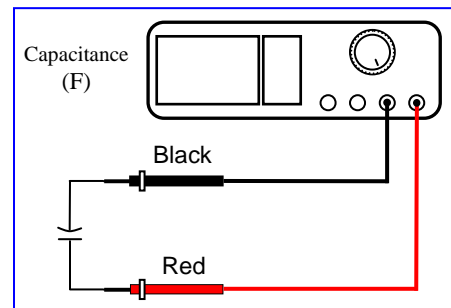

² The capacitor can be safely discharged by shorting a large resistor (e.g., 100 k Ω) across the two capacitor leads.

Appendix 1 – Resolution and Accuracy

DC Volts (mV DC)		
Range	Resolution	Accuracy (% rdg + digits)
400 mV	0.1 mV	$\pm (0.3\% \text{ rdg} + 5\text{d})$
4 V	1 mV	$\pm (0.3\% \text{ rdg} + 2\text{d})$
40 V	10 mV	$\pm (0.3\% \text{ rdg} + 2\text{d})$
400 V	100 mV	$\pm (0.3\% \text{ rdg} + 2\text{d})$

AC Volts (true rms, ac-coupled)		
Range	Resolution	Accuracy (% rdg + digits)
4 V	1 mV	$\pm (0.8\% \text{ rdg} + 5\text{d})$ 50Hz to 60Hz $\pm (1.2\% \text{ rdg} + 2\text{d})$ 45Hz to 1kHz
40 V	10 mV	
400 V	100 mV	

DC Current		
Range	Resolution	Accuracy (% rdg + digits)
4 mA	1 μA	$\pm (0.8\% \text{ rdg} + 5\text{d})$
40 mA	10 μA	$\pm (0.8\% \text{ rdg} + 5\text{d})$
400 mA	100 μA	$\pm (0.8\% \text{ rdg} + 5\text{d})$
10 A	10 mA	$\pm (1.5\% \text{ rdg} + 10\text{d})$

AC Current		
Range	Resolution	Accuracy (% rdg + digits)
4 mA	1 μA	$\pm (1.5\% \text{ rdg} + 5\text{d})$ 45Hz to 400Hz
40 mA	10 μA	$\pm (1.5\% \text{ rdg} + 5\text{d})$ 45Hz to 400Hz
400 mA	100 μA	$\pm (1.5\% \text{ rdg} + 5\text{d})$ 45Hz to 400Hz
10 A	10 mA	$\pm (2\% \text{ rdg} + 10\text{d})$ 45Hz to 400Hz

Resistance		
Range	Resolution	Accuracy (% rdg + digits)
400 Ω	0.1 Ω	$\pm (0.5\% \text{ rdg} + 5\text{d})$
4 k Ω	1 Ω	$\pm (0.5\% \text{ rdg} + 3\text{d})$
40 k Ω	10 Ω	$\pm (0.5\% \text{ rdg} + 3\text{d})$
400 k Ω	100 Ω	$\pm (0.5\% \text{ rdg} + 3\text{d})$
4 M Ω	1 k Ω	$\pm (1\% \text{ rdg} + 5\text{d})$
40 M Ω	10 k Ω	$\pm (1.5\% \text{ rdg} + 10\text{d})$

Capacitance		
Range	Resolution	Accuracy (% rdg + digits)
4 nF	1 pF	$\pm (2\% \text{ rdg} + 40\text{d})$ in relative mode
40 nF	10 pF	$\pm (2\% \text{ rdg} + 5\text{d})$ in relative mode
400 nF	100 pF	$\pm (2\% \text{ rdg} + 5\text{d})$ in relative mode
4 μF	1 nF	$\pm (2\% \text{ rdg} + 5\text{d})$
40 μF	10 nF	$\pm (2\% \text{ rdg} + 5\text{d})$ @ $\leq 20 \mu\text{F}$ $\pm (5\% \text{ rdg} + 5\text{d})$ @ $> 20 \mu\text{F}$

Appendix 2 – References

- [1] M9803R Bench Multimeter Users Manual, Precision Mastech Enterprises Co.