

Solution:

$$\text{BOD load} = 3.67 \text{ mgd} \times 128 \text{ mg/l} \times 8.34 = 3920 \text{ lb/day}$$

$$\text{MLSS in aeration tank} = 0.898 \text{ mil gal} \times 2350 \text{ mg/l} \times 8.34 = 17,600 \text{ lb}$$

$$\text{BOD loading} = 3920/120 = 32.7 \text{ lb/day/1000 ft}^3$$

$$\text{BOD loading} = 3920/17,600 = 0.22 \text{ lb/day/lb of MLSS}$$

Using Eq. (12.60),

$$\text{sludge age} = \frac{2350 \times 0.898}{26 \times 3.67 + 11,000 \times 0.0189} = 7.0 \text{ days}$$

$$\text{aeration period} = \frac{0.898 \times 24}{3.67} = 5.9 \text{ hr}$$

$$\text{return sludge rate} = \frac{1.27 \times 100}{3.67} = 35\%$$

$$\text{BOD efficiency} = \frac{(128 - 22)100}{128} = 83\%$$

$$\begin{aligned} \text{sludge production} &= \frac{0.0189 \text{ mgd} \times 11,000 \text{ mg/l} \times 8.34}{3920} \\ &= 0.44 \text{ lb SS wasted/lb BOD applied} \end{aligned}$$

12.20 OPERATION OF ACTIVATED-SLUDGE PROCESSES

Operation of an activated-sludge treatment plant is regulated by (1) the quantity of air supplied to the aeration basin, (2) the rate of activated-sludge recirculation, and (3) the amount of excess sludge withdrawn from the system. Sludge wasting is used to establish the desired concentration of MLSS, food/microorganism ratio, and sludge age.

Field observations for monitoring an aeration system are the rates of wastewater influent, excess sludge wasting, and sludge recirculation; the dissolved-oxygen concentration in the mixed liquor; and the depth of the sludge blanket in the final clarifier. Laboratory tests are used to determine influent and effluent BOD, the concentration of suspended solids in the return sludge, and the concentration of MLSS in the aeration tank. From these data, BOD loadings, the aeration period, the return sludge rate, and the BOD removal efficiency can be calculated. The final clarifier operation is observed by testing for the concentration of suspended solids in the effluent and calculating the overflow rate and solids loading.

The degree of treatment achieved in an activated-sludge process depends directly on the settleability of the suspended solids in the final clarifier. If the biological floc agglomerate and settle rapidly by gravity, the overflow is a clear supernatant. Conversely, poorly flocculated particles (pin floc) and buoyant filamentous growths that do not separate by gravity contribute to BOD and suspended solids in the system effluent.

lows:

e 12.3
nd of

TABLE 12.4 Factors That Can Adversely Affect Settleability of Activated Sludge

Biological Factors
Species of dominant microorganisms (filamentous)
Ineffective biological flocculation
Denitrification in final clarifier (floating solids)
Excessive volumetric and food/microorganism loadings
Mixed-liquor suspended-solids concentration
Unsteady-state conditions (nonuniform feed rate and discontinuous wasting of excess activated sludge)
Chemical Factors
Lack of nutrients
Presence of toxins
Kinds of organic matter
Insufficient aeration
Low temperature
Physical Factors
Excessive agitation during aeration resulting in shearing of floc
Ineffective final clarification: inadequate rate of return sludge, excessive overflow rate or solids loading, or hydraulic turbulence

Excessive carryover of floc resulting in inefficient operation is referred to as sludge bulking. This can be caused by any one or a combination of the biological, chemical, and physical factors listed in Table 12.4. If an activated-sludge process is not functioning properly, the loadings on the aeration tank and final clarifier are calculated and compared to established design criteria. Next, operational procedures are reviewed to ensure proper aeration, sludge recirculation, and sludge wasting. Special laboratory tests can be performed to determine detrimental chemical characteristics of the wastewater, such as a lack of nutrients or the presence of toxins. Microscopic examination of the activated sludge can reveal excessive filamentous growth [15].

12.21 ACTIVATED-SLUDGE TREATMENT SYSTEMS

Conventional Activated-Sludge Process

The conventional process diagrammed in Figure 12.32(a) is an outgrowth of the earliest activated-sludge systems constructed, used for secondary treatment of domestic wastewater. The aeration basin is a long rectangular tank with air diffusers on one side of the tank bottom to provide aeration and mixing. Settled raw wastewater and return activated sludge enter the head of the tank and flow down its length in a spiral flow pattern. An air supply is tapered along the length of the tank to provide a greater amount of diffused air near the head where the rate of biological metabolism and resultant oxygen demand are the greatest. A conventional activated-sludge aeration tank is shown in Figure 12.33.

The conventional activated-sludge process uses bubble air diffusers set at a depth of 8 ft or more to provide adequate oxygen transfer and deep mixing. Several different

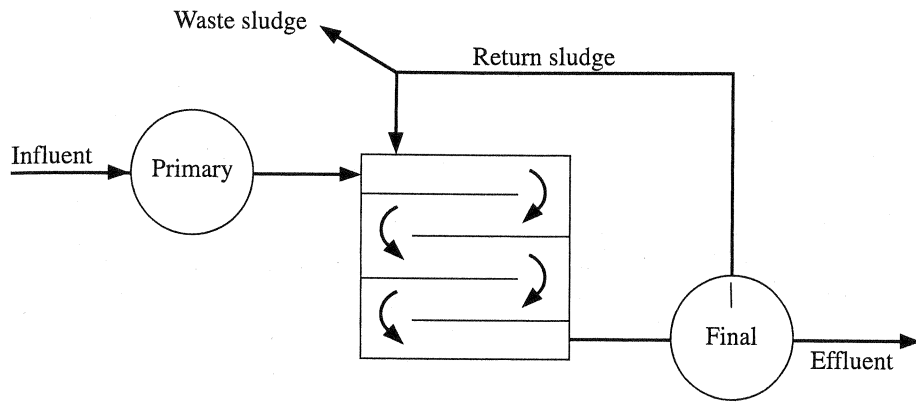

(a)

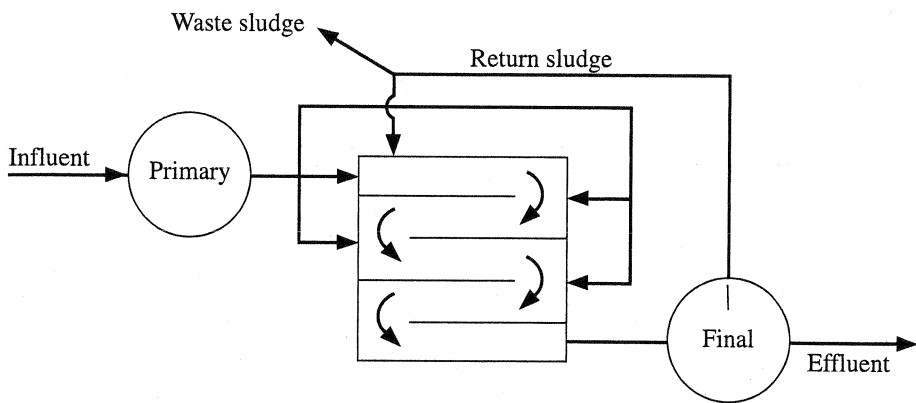

(b)

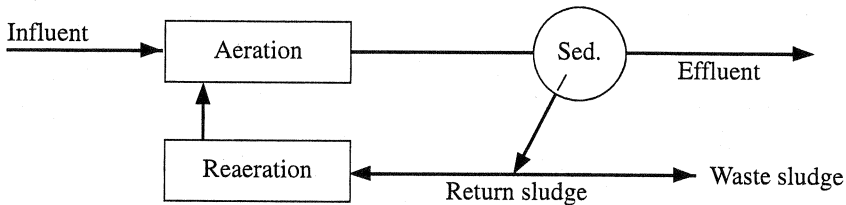

(c)

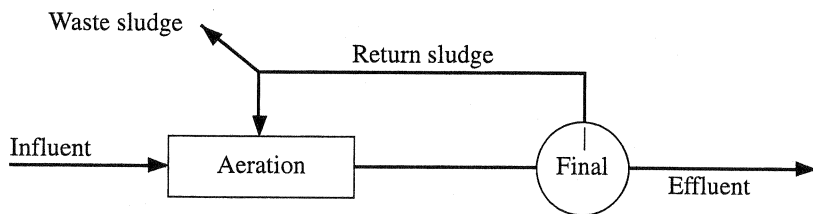

(d)

FIGURE 12.32 Flow diagrams for common activated-sludge processes. (a) Conventional activated-sludge process. (b) Step-aeration activated-sludge process. (c) Contact stabilization without primary sedimentation. (d) Extended aeration without primary sedimentation.

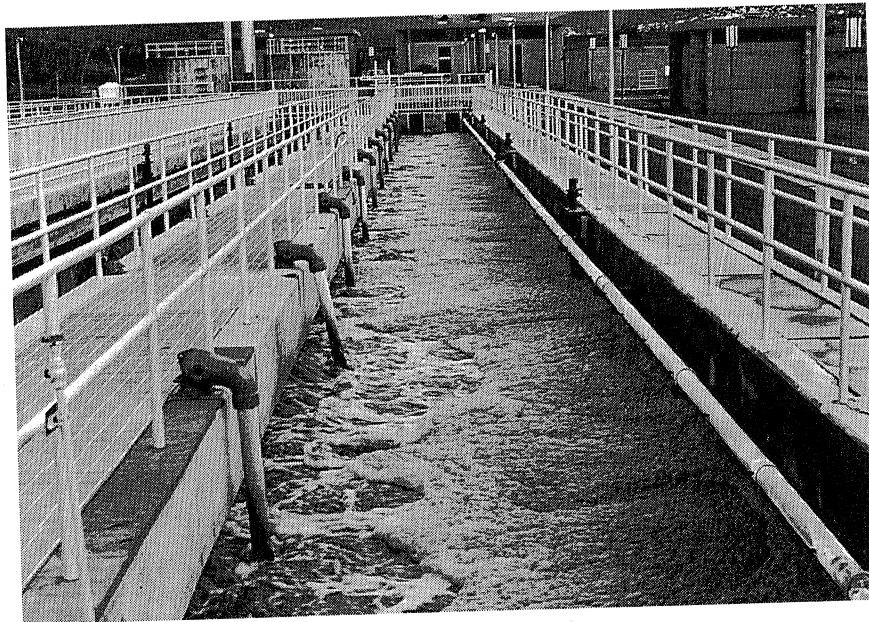

(a)

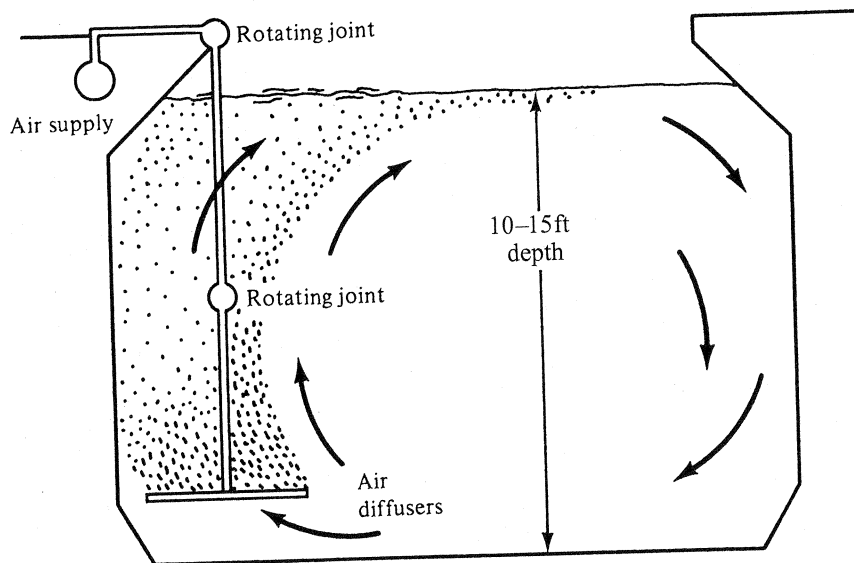

(b)

FIGURE 12.33 Conventional activated-sludge process. (a) Long rectangular aeration tank with submerged coarse-bubble diffusers along one side (Santee, CA). (b) Cross section of a typical aeration tank illustrating the spiral flow pattern created by aeration along one side.

bubble diffusers are manufactured; common kinds are stainless-steel or hollow-cylinder porous tubes 1–2 ft in length or porous disks about 6 in. in diameter. These individual diffusers are attached along a submerged air header about 10 ft in length attached to an air-supply hanger pipe. For maintenance of the diffusers, the hanger pipe can be designed with rotating joints (a swing-diffuser arm) so the header can be retracted using a portable jack. The tops of swing-diffuser hanger arms can be seen in Figure 2.33(a) along the aeration tank.

Step-Aeration Activated-Sludge Process

The *step-aeration process* [Fig. 12.32(b)] is a modification of the conventional process. Instead of introducing all raw wastewater at the tank head, raw flow is introduced at several points along the tank length. Stepping the influent load along the tank produces a more uniform oxygen demand throughout. While tapered aeration attempts to supply air to match oxygen demand along the length of the tank, step loading provides a more uniform oxygen demand for an evenly distributed air supply.

Both step-aeration and conventional processes can use fine-bubble aeration. Fine-bubble diffusers produce bubbles with a diameter of approximately 2–5 mm (0.08–0.20 in.) in clean water. The three general categories of fine-pore media are ceramics, porous plastics, and perforated membranes. As illustrated in Figure 12.34, individual diffusers are mounted on holders attached to air piping on the tank bottom. Each membrane or ceramic disc, either 9 in. or 7 in. in diameter, is sealed to a holder by a screw-on retainer ring with an O-ring seal. With the diffusers over the entire floor area, the rising streams of fine bubbles mix and aerate the mixed liquor uniformly, keeping the microbial floc in suspension. The benefit of fine-bubble aeration is a power savings of 40%–60% when compared to coarse-bubble or mechanically aerated activated-sludge processes [16]. As a result of cost savings and system performance, use of fine-bubble aeration is now common in activated-sludge processes, particularly with automated control. Automated aeration control is the manipulation of the aeration rate by computer to match the dynamic oxygen demand and maintain the desired residual dissolved-oxygen concentration in the mixed liquor.

Example 12.10

A step-aeration activated-sludge process is being sized for a settled wastewater flow of 7.40 mgd (989,000 ft³/d) containing 7900 lb of BOD. The design maximum BOD loading is 40 lb/1000 ft³/day, and the design minimum aeration period is 6.0 hr. (1) Calculate the dimensions for 4 identical aeration tanks. (2) Calculate the dimensions for 4 circular final clarifiers. (3) If the proposed minimum operating MLSS is 2000 mg/l, what is the calculated F/M at design loading?

Solution:

$$1. \quad V \text{ (based on BOD loading)} = \frac{7900 \times 1000}{40} = 198,000 \text{ ft}^3$$

$$V \text{ (based on aeration period)} = \frac{7,400,000 \times 6.0}{24 \times 7.48} = 247,000 \text{ ft}^3$$

Use 247,000 ft³ with an aeration period of 6.0 hr, which results in a BOD loading of 32 lb/1000 ft³/day. Install 4 aeration tanks with 13 ft liquid depth and 24 ft width for fine-bubble aeration.

$$\text{length of each tank} = \frac{247,000}{4 \times 13 \times 24} = 198 \text{ ft}$$

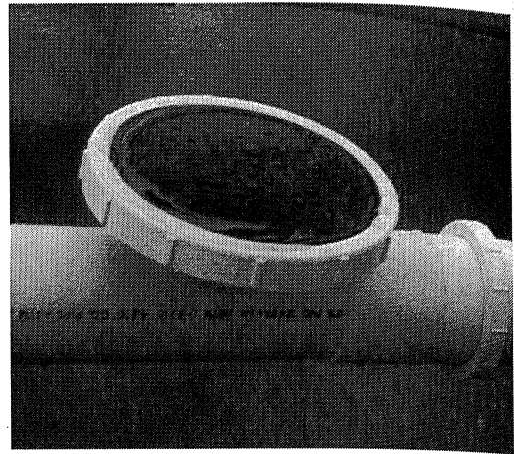
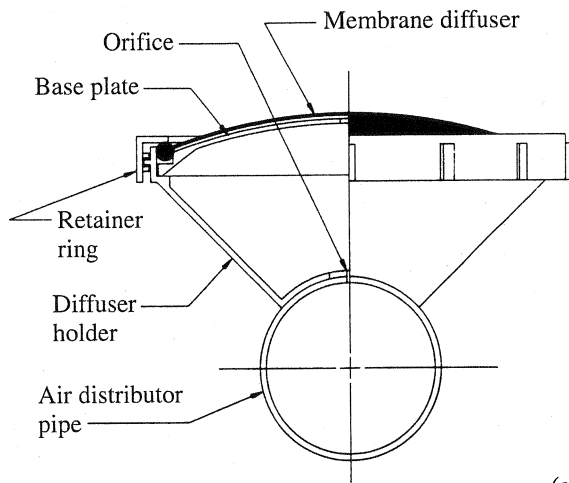

(a)

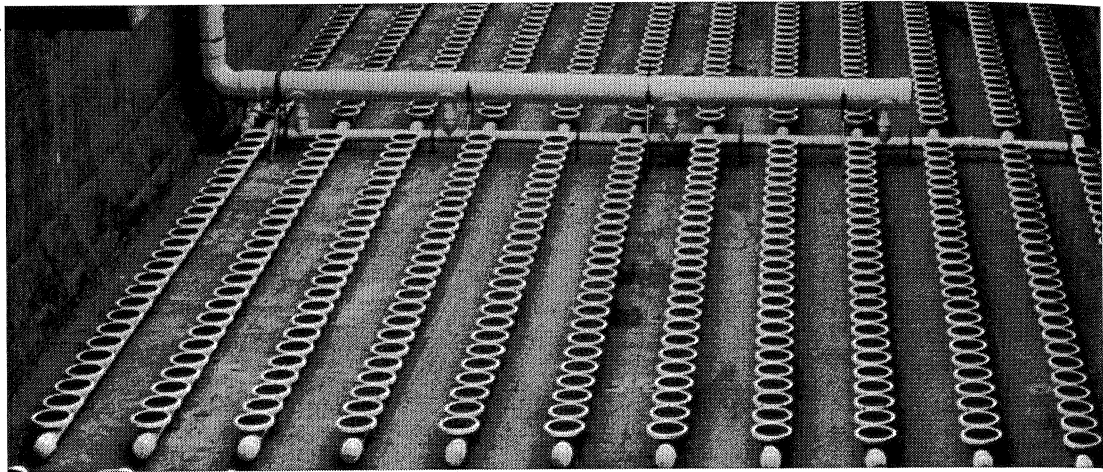

(b)



(c)

FIGURE 12.34 Fine-bubble diffuser for wastewater aeration. (a) A disc diffuser mounted on top of an air distributor pipe. (b) A grid of diffusers attached to air pipes mounted on the floor of an aeration tank. (c) Long rectangular aeration tank with uniform mixing and oxygenation by a grid of fine-bubble diffusers. *Source:* Courtesy of Sanitaire, a division of ITT Industries, Inc.

2. From Section 10.16, use an overflow rate of 800 gpd/ft² and side-water depth of 11 ft to size 4 circular clarifiers.

$$\text{surface area} = \frac{7,400,000}{4 \times 800} = 2310 \text{ ft}^2 \quad (\text{diameter} = 54 \text{ ft})$$

$$\text{detention time} = \frac{2300 \times 11 \times 24}{989,000/4} = 2.5 \text{ hr}$$

3. $F/M = \frac{7900}{2000 \times 1.85 \times 8.34} = 0.26 \text{ lb BOD/day/lb of MLSS}$

Contact-Stabilization Activated-Sludge Process

This process [Fig. 12.32(c)] provides for reaeration of the return activated sludge from the final clarifier, allowing this process to have a smaller aeration tank. The sequence of aeration–sedimentation–reaeration has been used as a secondary treatment process in large plants but is rare in new design. Current use is of complete aerobic treatment without primary sedimentation in factory-built, field-erected plants with capacities of 0.05–0.5 mgd, as pictured in Figure 12.35. Using common walls for economical construction, the plant consists of two concentric circular tanks about 14 ft deep with the inner shell 15–30 ft in diameter and the outer tank 30–70 ft in diameter. The doughnut-shaped space between the two tanks is divided into three chambers for aeration, reaeration, and aerobic digestion. The circular chamber in the center is the final settling tank. The plant can also be segmented and constructed for extended aeration or step-aeration processes.

The sequence of operation for contact stabilization is aeration of the raw wastewater with return activated sludge, sedimentation to overflow clarified effluent, and reaeration of the settling tank underflow with a portion wasted to the aerobic digester. Supernatant drawn from the digester is returned to the aeration chamber. Periodically, aeration to the aerobic digester is stopped and suspended solids allowed to settle for withdrawal of gravity-thickened sludge for disposal.

Example 12.11

A contact-stabilization plant, similar to the one diagrammed in Figure 12.35(a), has compartments with the following liquid volumes:

$$\text{aeration chamber} = 85 \text{ m}^3$$

$$\text{reaeration chamber} = 173 \text{ m}^3$$

$$\text{aerobic digester} = 153 \text{ m}^3$$

$$\text{sedimentation tank} = 122 \text{ m}^3 \text{ (30.7-m}^2 \text{ surface area)}$$

If the plant is designed for an equivalent population of 2000 persons, calculate the BOD loading, aeration periods, and detention times.

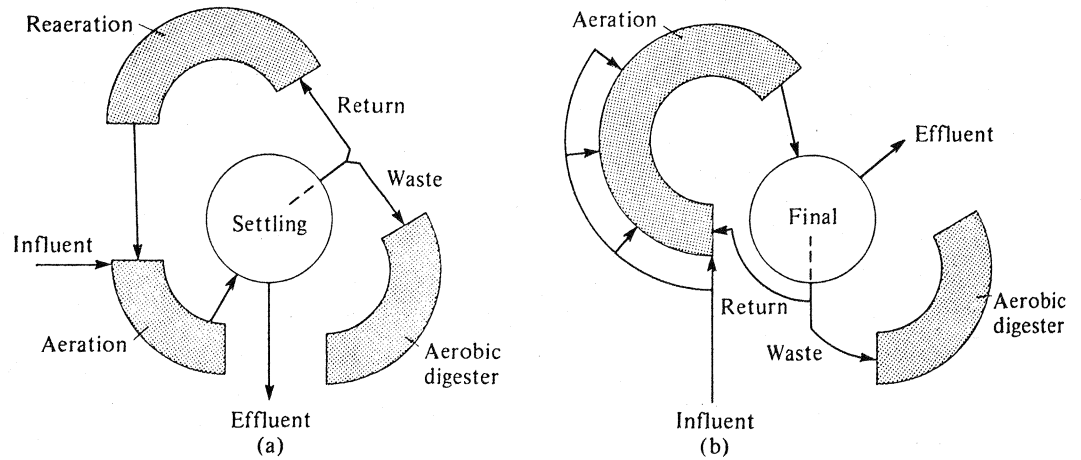
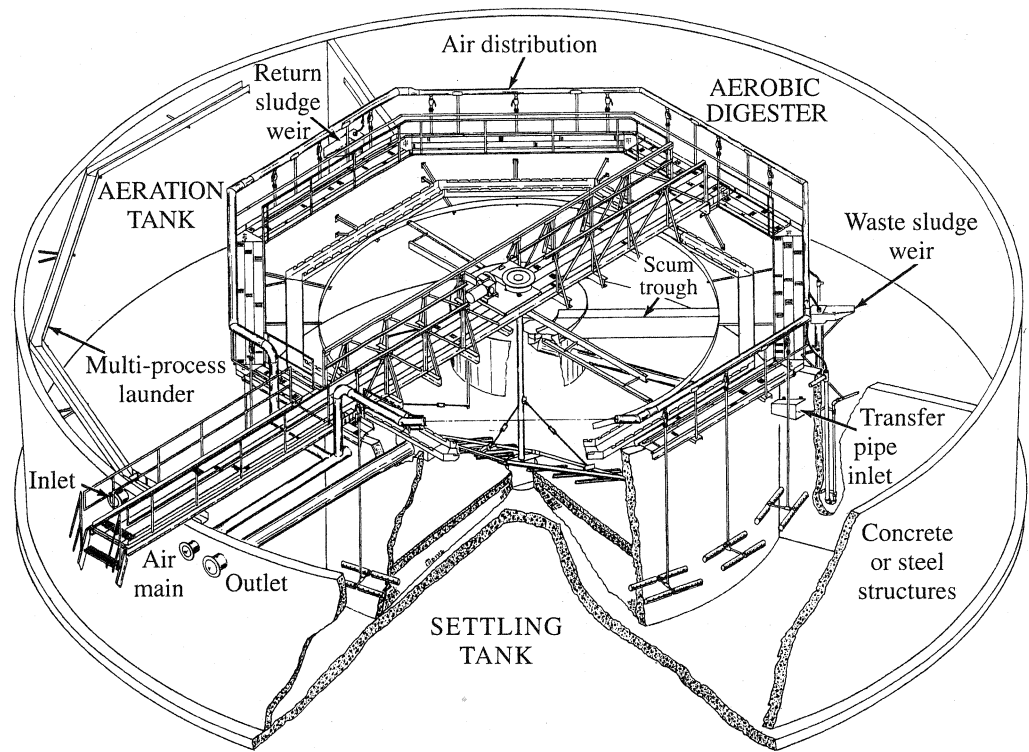

FIGURE 12.35 Field-erected circular steel wastewater treatment plant for extended-aeration, step aeration, or contact stabilization processes. Drawing shows a cutaway view of the aeration tank and clarifier. (a) Contact stabilization (b) Extended or step aeration. Source: Courtesy of Sanitaire, a division of ITT Industries, Inc.

Solution:

$$\begin{aligned}
 \text{hydraulic load} &= 2000 \times 450 \text{ l/person} \\
 &= 900,000 \text{ l/d} = 900 \text{ m}^3/\text{d} \\
 \text{BOD load} &= 2000 \times 91 \text{ g/person} \\
 &= 182,000 \text{ g/d}
 \end{aligned}$$

$$\text{BOD loading on aeration tanks} = \frac{182,000}{85 + 173} = 705 \text{ g/m}^3 \cdot \text{d}$$

$$\text{aeration period (based on raw wastewater flow)} = \frac{85 \times 24}{900} = 2.3 \text{ h}$$

$$\text{reaeration period (based on raw wastewater flow)} = \frac{173 \times 24}{900} = 4.6 \text{ h}$$

The detention time for sedimentation (assuming 100% recirculation flow) is

$$\frac{122 \times 24}{2 \times 900} = 1.6 \text{ h}$$

The overflow rate on final clarifier (based on effluent flow) is

$$\frac{900}{30.7} = 29.3 \text{ m}^3/\text{m}^2 \cdot \text{d}$$

Extended-Aeration Activated-Sludge Process

The extended-aeration process [Fig. 12.32(d)] is used primarily to treat wastewater flows from residential communities and small municipalities. The aeration period is 24 hr or greater, with complete mixing of the aeration tank and, because of low BOD loading, the activated-sludge process operates in the endogenous growth phase. As a result, the biological process is very stable and can accept variable loading. Waste sludge is discharged to an aerobic digester for stabilization prior to disposal. Final settling tanks are conservatively sized for a long detention time and a low overflow rate, generally in the range of 200–600 gpd/ft² for aeration tank volumes in the range of 5000–150,000 gal.

A well-known extended-aeration process is the closed-loop reactor, or oxidation ditch, aerated and mixed by horizontal rotors, as illustrated in Figure 12.36. The modern reactor is an elongated oval with vertical walls and a center dividing wall; earlier ditches had sloping side walls with a center island. In reactor design, the wastewater depth is up to 16 ft with 2-ft freeboard, and channel width is up to 31 ft, with the horizontal rotors spanning the full width of the channel. The flow diagram in Figure 12.36(a) shows parallel operation of two reactors, which can be changed to series operation by adjusting slide gates. Also, if one reactor is to be taken out of service temporarily for inspection, operation of the plant can continue, although at higher volumetric loading.

Dimensions of the reactor must conform to design criteria established by the manufacturer of the horizontal rotors. For example, for the horizontal rotor with individual blades illustrated in Figure 12.36(b) (Lakeside's *Magna Rotor*), the maximum liquid depth of channel is 16 ft, rotor diameter is 42 in. with minimum design immersion of 5 in., and available length is 5–30 ft. Manufacturers also provide design data on rate of oxygen transfer and installation requirements. As pictured, rotor covers are available to contain spray and to reduce cooling of the mixed liquor in low-temperature operation.