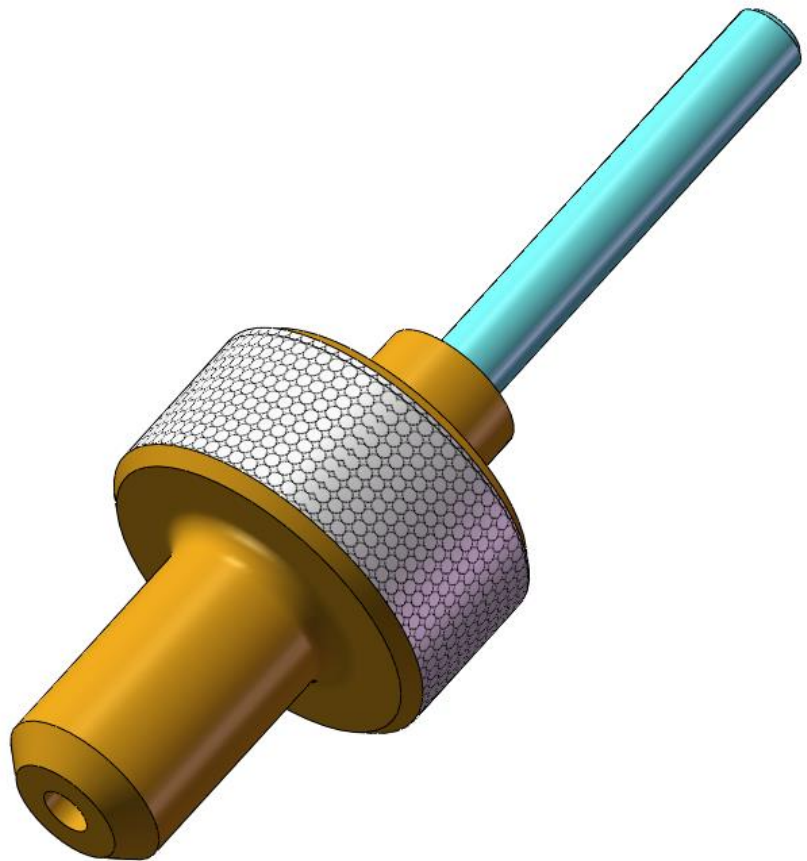


# **DESIGN**

**for**

# **FIT**

**Applications of Geometric Tolerancing  
to Machine Design**



**Second Edition**

**Faryar Etesami  
Portland State University**

# **Design for Fit**

Applications of Geometric Tolerancing to Machine Design

Second Edition

Faryar Etesami

Mechanical and Materials Engineering Department  
Portland State University

ISBN 978-0-9914638-0-0

Copyright © 2016 by Faryar Etesami

All rights reserved. No part of this book may be reproduced or transmitted electronically or otherwise without permission in writing from the publisher.

The information presented in this book and any associated software is included for educational purposes only. The author and publisher make no warranties of any kind with regard to applicability or validity of the materials presented in this book.

Send Correspondence to: [Design4Fit@gmail.com](mailto:Design4Fit@gmail.com)

## Preface

This book is written for students enrolled in an undergraduate program in mechanical engineering (BSME) or similar programs. The material presented is based on my notes for teaching mechanical tolerancing for nearly thirty years. The book's emphasis is on fit and alignment requirements for machine components. Fit assurance makes up the majority of challenging applications in tolerancing. Design for specific functions is easy by comparison. For design engineers, knowing how to apply geometric tolerances has been a challenge even for engineers who have practiced geometric tolerancing for a long time. The syntax and meaning of geometric tolerancing statements can be learned easily and quickly but knowing how to use them correctly is much more difficult. For years I taught the geometric tolerancing standards in great detail as one may teach a foreign language using a dictionary. That method of training was fine for those on inspection or manufacturing career paths but was not very useful to design engineers. Finally, I decided to teach the subject not as a geometric tolerancing class but as a design-for-fit class. I found this new method to be far more effective and useful to design engineers than covering every detail of the GDT standard.

The objective of this book is to present the subject of design-for-fit in a format that is suitable as a college-level course. I believe students learn in the context of simple examples free of distractions. They are then able to apply what they learned in more complex applications. For that reason, I have done my best to convey the concepts of design for fit in the context of simple examples. **Graduating mechanical engineers who design and document parts and assemblies should have a basic understanding of the design-for-fit principles presented in Chapters 1-9.** The book can be used to support a junior-level or senior-level class in a BSME program or it can make a companion textbook for capstone design classes. Interested students or practitioners can follow up with the more advanced topics in Chapter-10 and Chapter-11 on multipart fits and fit analysis. Since this book does not cover every detail of the geometric tolerancing standard I recommend having a copy of the standard document as an official and legal reference. Low-cost pdf versions of the GDT standard can be found online.

Faryar Etesami  
January 2016

# CONTENTS

## Chapter-1

### Dimensions and Tolerances..... 5

1.1.	Overview.....	5
1.2.	Evolution of tolerancing .....	6
1.3.	Geometric versus dimensional tolerances.....	10
1.4.	Importance of clear geometry communication practices.....	15
1.5.	Functional feature vocabulary.....	16
1.6.	Preferred practices in dimensioning .....	20
1.7.	Figures of accuracy for dimensions and tolerances.....	38

## Chapter-2

### A Design Engineer's Overview of Tolerance Statements - Part-I..... 44

2.1.	Overview .....	44
2.2.	Interpretation of geometric tolerances .....	44
2.3.	Dimensional tolerances .....	46
2.4.	Geometric tolerances.....	47
2.5.	Tolerances of form.....	50
2.6.	Flatness .....	50
2.7.	Meaning of $\textcircled{M}$ symbol next to the tolerance value .....	53
2.8.	Straightness .....	55
2.9.	Circularity.....	56
2.10.	Cylindricity.....	58
2.11.	Tolerances of orientation .....	59
2.12.	Parallelism.....	61
2.13.	Identifying the axis of an imperfect cylinder .....	62
2.14.	Perpendicularity.....	67
2.15.	Angularity .....	70

## Chapter-3

### A Design Engineer's Overview of

#### Tolerance Statements - Part-II..... 77

3.1.	Overview .....	77
3.2.	Tolerances of location .....	77
3.3.	Position tolerance.....	77
3.4.	Meaning of $\textcircled{M}$ modifier applied to datum features .....	91
3.5.	Composite position tolerance – multiple segments .....	93
3.6.	Composite position tolerance – single segment.....	96
3.7.	Runout tolerances.....	98
3.8.	Profile tolerances.....	107
3.9.	Profile tolerances in place of $\pm$ tolerances .....	112

## Chapter-4

#### Default Tolerances.....128

4.1.	Overview.....	128
4.2.	Default tolerancing methods.....	128
4.3.	Datum targets.....	133
4.4.	Default tolerancing and small features .....	137
4.5.	Default tolerances for fillets and rounds.....	138
4.6.	A different way of dealing with small features .....	139

## Chapter-5

### Tolerance Design for Unconstrained Fits Between Two Parts

#### Part-I .....150

5.1.	Overview.....	150
5.2.	Unconstrained fits versus constrained fits.....	150
5.3.	Fit assurance between two parts .....	154
5.4.	Theoretical gages for tolerance statements that use the $\textcircled{M}$ symbol .....	160
5.5.	Fit formula .....	161
5.6.	Default form control implied by limits of size .....	164
5.7.	Use of zero geometric tolerance at MMC.....	165
5.8.	Fit formula when using zero geometric tolerancing at MMC.....	167
5.9.	Defining a fit boundary without the $\textcircled{M}$ modifier .....	167
5.10.	A note on the use of modifiers.....	168

5.11.	<i>Unconstrained fits and Rule#1</i> .....	169
5.12.	<i>Unconstrained interference fits</i> .....	171

## Chapter-6

### Tolerance Design for Unconstrained Fits Between Two Parts

#### Part-II .....176

6.1.	<i>Overview</i> .....	176
6.2.	<i>An overview of the limits and fits standard (ANSI B4.2)</i> .....	178
6.3.	<i>Preferred sizes</i> .....	180
6.4.	<i>Offsets letters (fundamental deviations indicator letters)</i> .....	181
6.5.	<i>International tolerance grades</i> .....	183
6.6.	<i>Preferred fits</i> .....	183
6.7.	<i>Dependency of offsets and tolerance grades on basic size</i> .....	194
6.8.	<i>Tolerance design examples in precision fit applications</i> .....	194

## Chapter-7

### Tolerance Design for Orientation-constrained Fits

#### Between Two Parts .....208

7.1.	<i>Overview</i> .....	208
7.2.	<i>The fit boundary and the theoretical gage</i> .....	210
7.3.	<i>A word on inspection</i> .....	216
7.4.	<i>MMC boundary as fit boundary</i> .....	217
7.5.	<i>Situations where MMC modified tolerances cannot be used</i> .....	219
7.6.	<i>Datum feature flatness</i> .....	220
7.7.	<i>Is it necessary to specify axis straightness?</i> .....	225
7.8.	<i>Defining a fit boundary without the <math>\textcircled{M}</math> modifier</i> .....	227

## Chapter-8

### Tolerance Design for Location-constrained Fits

#### Between Two Parts .....230

8.1.	<i>Overview</i> .....	230
8.2.	<i>The fit boundary and the theoretical gage</i> .....	231
8.3.	<i>Datum priority</i> .....	236
8.4.	<i>Datum frame precision</i> .....	241
8.5.	<i>Imperfect geometry relationships are not intuitive</i> .....	243

8.6.	<i>Fit of feature patterns</i> .....	245
8.7.	<i>Simultaneous fit of different features</i> .....	248
8.8.	<i>Additional alignment fit features</i> .....	252
8.9.	<i>Situations where the use of <math>\textcircled{M}</math> is not possible or recommended</i> .....	255
8.10.	<i>Defining a fit boundary without the <math>\textcircled{M}</math>modifier</i> .....	256

## Chapter-9

### **Assemblies with Threaded Fasteners.....267**

9.1.	<i>Overview</i> .....	267
9.2.	<i>Fits using threaded studs or screws</i> .....	267
9.3.	<i>Fits using threaded press-fit studs</i> .....	269
9.4.	<i>Assembly with cap screws and threaded holes</i> .....	271
9.5.	<i>Assembly of two plates with loose bolts and nuts</i> .....	272
9.6.	<i>Fastener applications - Example-1</i> .....	274
9.7.	<i>Fastener applications - Example-2</i> .....	277
9.8.	<i>Fastener applications - Example-3</i> .....	279
9.9.	<i>Fastener applications - Example-4</i> .....	282
9.10.	<i>Tolerance design of press-fit inserts</i> .....	287

## Chapter-10

### **Tolerance Design of Multipart Fits.....295**

10.1.	<i>Overview</i> .....	295
10.2.	<i>Application of profile tolerances</i> .....	296
10.3.	<i>Fits involving features-of-size</i> .....	301

## Chapter-11

### **Tolerance Analysis of Multipart Fits .....338**

11.1.	<i>Overview</i> .....	338
11.2.	<i>Tolerance analysis overview</i> .....	338
11.3.	<i>Examples</i> .....	339

# Chapter -1

## Dimensions and Tolerances

### 1.1. Overview

This chapter presents an introduction to tolerancing practice and suggests guidelines for clear graphics communication. After a part's exact geometry is defined in a CAD system a design engineer must also specify the part's geometric tolerances. Tolerances define allowable deviations of part features from their theoretical definitions. Since manufacturing variations are inevitable, tolerancing information allows production personnel to select suitable processes and methods to meet part precision requirements at minimum cost.

Tolerancing specifications include tolerance types and tolerance values. For example, if a surface is to be flat with high precision, then the designer applies a standard flatness tolerance symbol and specifies a tolerance value. The smaller the tolerance value, the more flat the surface would be manufactured, but usually at a higher cost. The geometric tolerancing standard to which the material in this book refers to is the ASME Y14.5-2009 standard, which from now on, will be referred to as the GDT standard. The GDT standard provides a variety of symbols a designer can use to control various geometric aspects of a part.

The design engineer's challenge is to create a set of precision specifications that is just enough to assure proper fit and function of a part in an assembly. The ability to create well-toleranced parts is an important skill for a mechanical design engineer. Improper use of tolerance types or tolerance values can affect the cost of production as well as the fit and function of assemblies. To be safe, many designers resort to over-specification of tolerances. Tolerance types that are not needed or tolerance values that call for unnecessary precision would lead to higher production costs and delays in a variety of ways such as:

- The need for more expensive processes or machines
- The need for additional or more time-consuming processing steps
- Lack of in-house capability
- The need for more expensive tooling
- A reduction in throughput
- The need for more expensive inspection tools
- An increase in rework and reject rates
- Excessive lead-times

On the other hand, lack of necessary tolerance types or tolerance values that do not call for enough precision reduce the cost of production at the risk of non-assembly or functional compromises. Some of the more common failures associated with lack of sufficient geometric precision are:

- Risk of parts not fitting properly into an assembly

- Improper performance
  - Improper sealing
  - Loss of operation accuracy
  - Loss of power
  - Loss of functionally critical alignments
  - Improper thermal or electrical conduction
- Structural Failures
  - Improper load distribution
  - Unexpected dynamic loads
  - Unexpected loading modes
  - Unacceptable changes of stiffness
- Reduced service life
  - Excessive friction or wear
  - Excessive noise
  - Excessive heat
  - Excessive vibration

The great majority of tolerancing needs for typical parts relate to their fit requirements or their alignment requirements necessary for fit. For that reason, this book primarily discusses tolerancing needs for proper fit.

Like other engineering specifications, good tolerancing is not merely about what works but what works at minimum cost. Geometric tolerances have a significant impact on the final production costs.

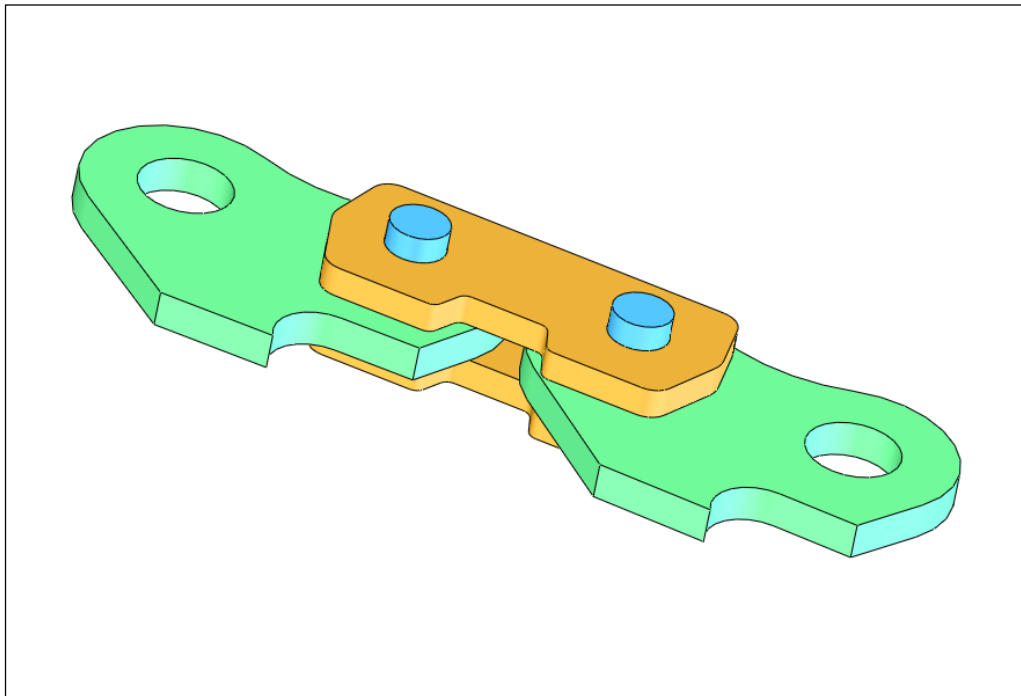
## **1.2. Evolution of tolerancing**

Before the industrial revolution, craftsmen often made the necessary parts of an assembly and fit them together in their shops. Each part was custom made to fit where it needed to fit. It was neither necessary nor wise to make all of the parts first and hope they would fit together properly at the end. The practice of build-and-fit was possible because the entire assembly was made by the same skilled worker in the same shop. Customers simply expected the entire assembly to work as described with some desired overall dimensions. Even today prototypes are often made this way because this method requires less precision work than building all of the parts first and fitting them together later. It is also easier and quicker for the design engineers to leave all the details to the manufacturing personnel as long as the assembly works at the end.

Mass production made the build-and-fit scheme impractical. Parts needed to be made on different machines and task specialization allowed high throughputs. Other skilled workers or machines put the parts together forming the final assemblies. The necessity of faster product introduction also resulted in specialization of skills. Shape design became the responsibility of the designers, draftsmen assisted designers by creating detailed drawings, production specialists designed the tooling and produced parts most efficiently, and quality control specialists checked the accuracy of the parts. Drafting guidelines

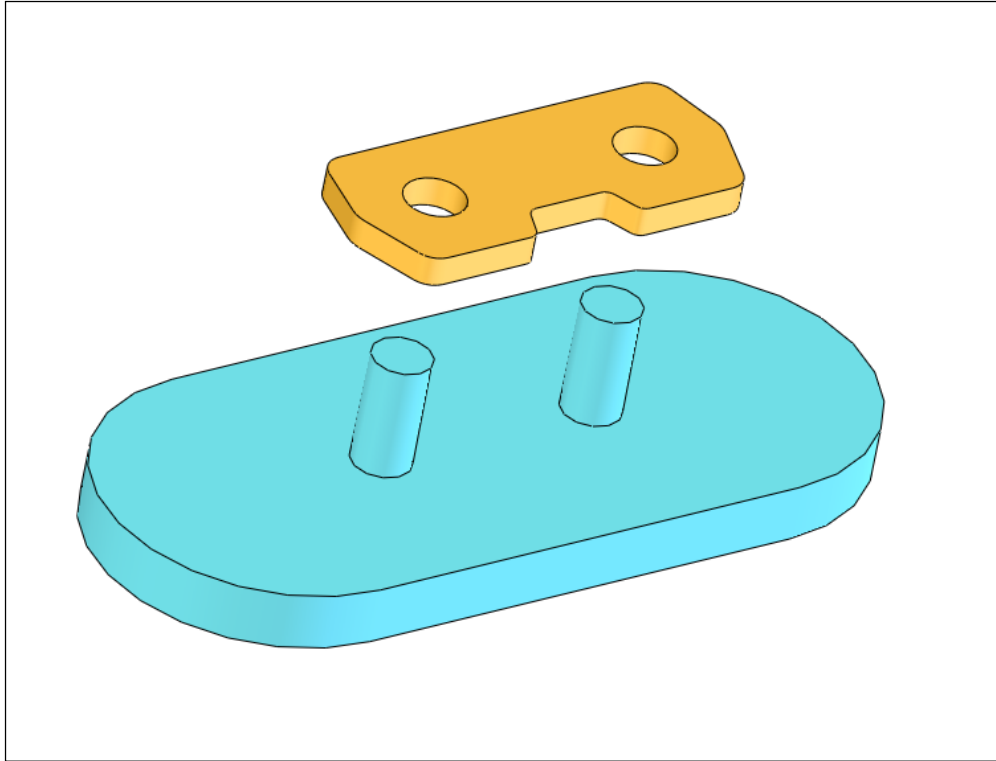
were introduced to standardize the graphical communication of geometric information between designers, manufacturing, and quality control people.

To make sure that the parts were made with sufficient accuracy to fit together during assembly, design engineers had functional gages built and sent with their drawings that described the part dimensions. Each functional feature of a part was to be checked with two types of physical gages, a GO gage and a NOT GO gage. A part that would fit the GO gage was assured to fit a mating part in the assembly. The GO gage, sometimes made of wood, simply represented the worst-case geometry of a mating part for fit purposes. Figure 1-1 shows a portion of a chainsaw assembly.



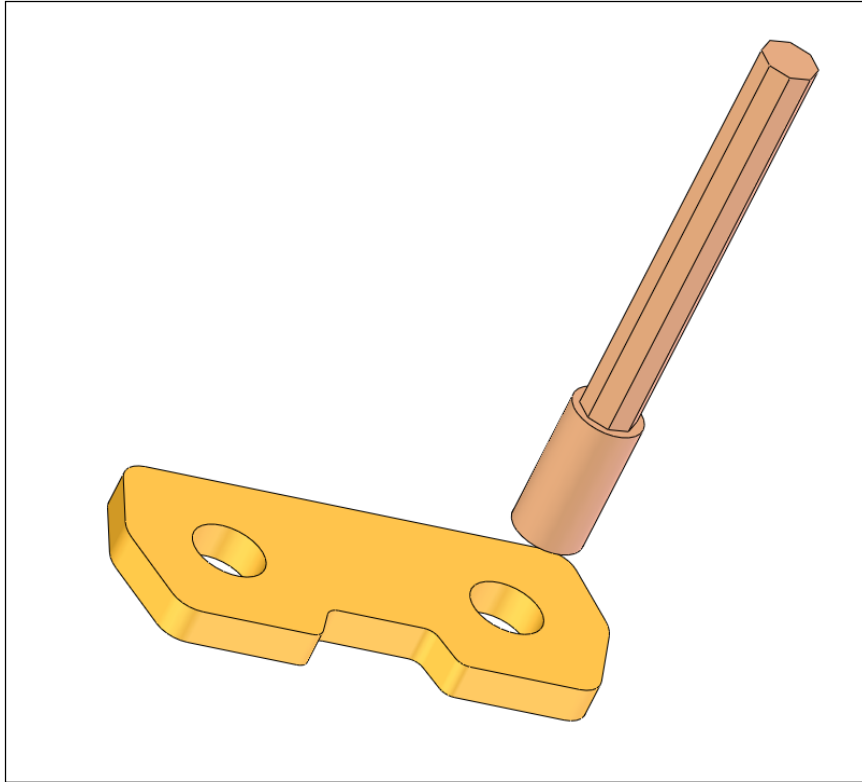
**Figure 1-1. A portion of a chainsaw assembly**

Figure 1-2 shows a chainsaw link with its two critical holes along with a GO gage which is a flat plate with two pins. GO gages simulate the contacting surfaces and fitting features of a mating part.



**Figure 1-2. The chainsaw link and a GO gage checking its fit to a mating part**

GO gages check the fit of a feature into assembly but they do not check for excessive play in the fit when the holes are too large. NOT GO gages were used to make sure the holes were not too large. A hole that would go through a NOT GO gage was too large leading to a loose fit and creating too much slack or play to be functionally acceptable. The NOT GO gage for the chain link is a plug gage that is used individually on each hole. The chain link and the plug gage are shown in Figure 1-3.



**Figure 1-3. A NOT GO plug gage for checking the size of each hole in the chainsaw link**

An acceptable part feature would clear the GO gage, assuring fit, but not the NOT GO gage, assuring acceptable play and proper function. Other non-critical features of parts were assumed to be acceptable as made when the tools and workmanship conformed to established standards of good manufacturing. No gages were made for non-critical features.

Building and sending physical gages with part drawings were difficult to do in a design environment. In later years, design engineers simply created separate drawings necessary to build the gages at the manufacturing site with some added precision instructions. The precision instructions, or tolerancing instructions, were in the form of  $\pm$  variation limits on the dimensions of the gages to be made. With this additional description of accuracy, the gages could be built at the manufacturing site where the parts were being made. Eventually, these  $\pm$  limits were directly applied to the part dimensions from which appropriate gages could be made to verify the fit and function of precision features. This eliminated the need for the designers to create multiple sets of drawings, one for the part and others for the gages. It also became easy to simply check the dimensions of the part for conformance. Unfortunately, this practice led to serious unintended consequences. Applying dimension limits by designers and checking dimensions by inspectors became the norm in tolerancing until it was replaced by geometric tolerancing practices that once again introduced the concepts of functional gaging back into the tolerancing standards and tolerancing practice.

### 1.3. Geometric versus dimensional tolerances

At the time of its introduction, the geometric variation control based on  $\pm$  limits on part dimensions and angles were logical extensions of dimensioning, easy to apply, easy to understand, and easy to verify. However, the ease of dealing with dimension limits is true only when the geometry of the part remains free of deformations and distortions. Deformations and distortions make it difficult to interpret the meaning of dimension limits without subjectivity. As more knowledge was gained regarding the geometric requirements of fit and function, it became clear that dimensional tolerances alone did not provide the best specification toolbox for assuring fit and function.

The concept of gaging and gage description is at the heart of what constitutes geometric tolerancing. A simple example can highlight the advantage of geometric tolerancing over just using dimension limits. Consider rolling a heavy, tall refrigerator on casters past a doorway. The width of the refrigerator is just below 835 mm and the width of the doorway is just over 835 mm. There is a good chance, however, that the refrigerator would not fit through. Figure 1-4 highlights the point.

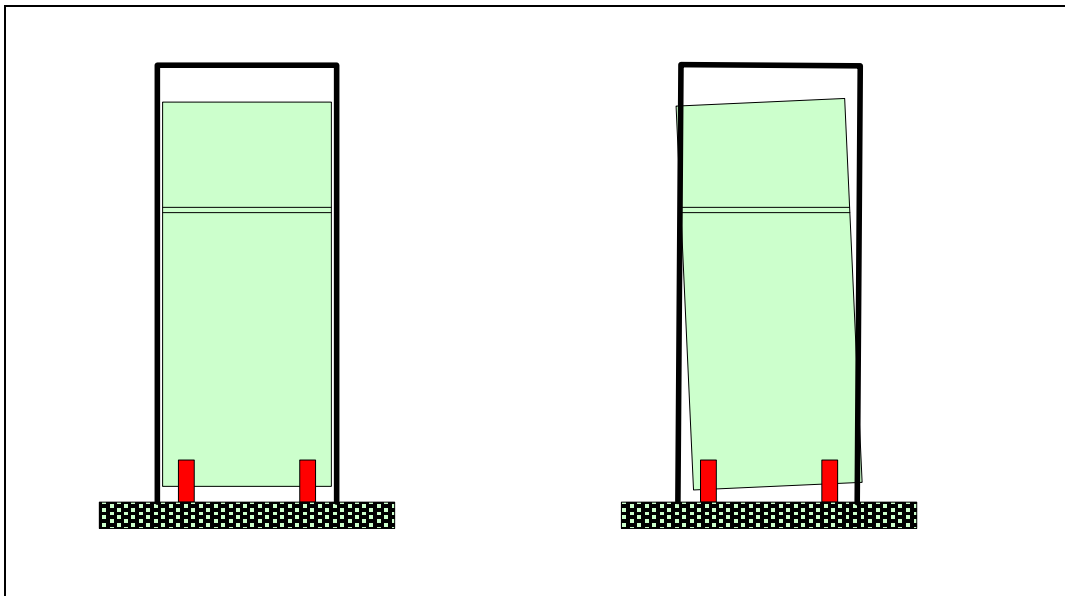
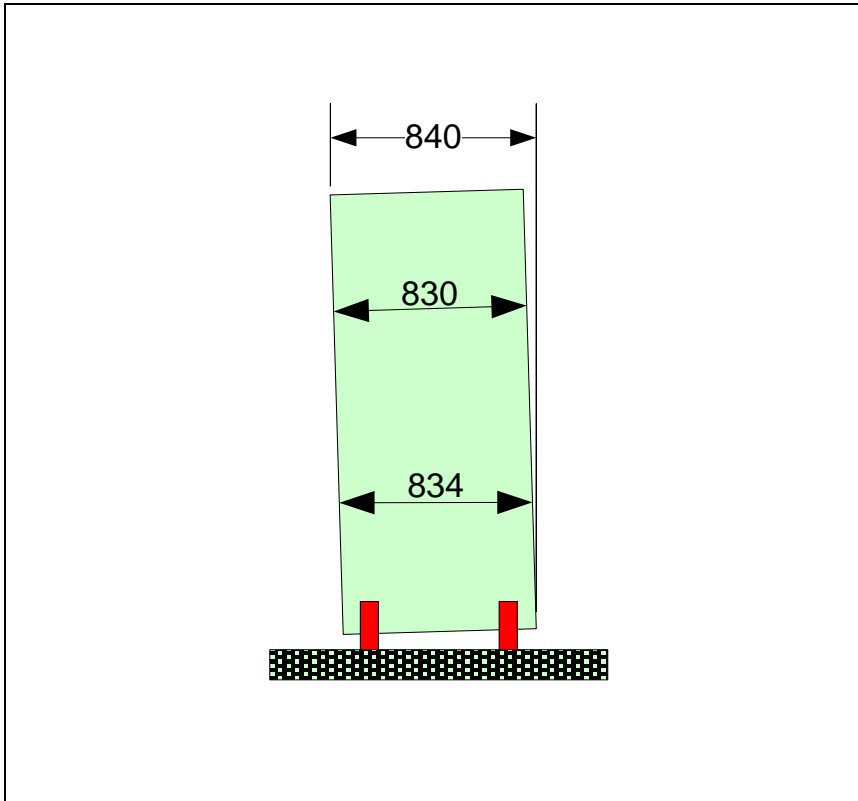


Figure 1-4. The width of the refrigerator alone may not be sufficient to assure fit

On the left figure, the refrigerator and the doorway are shown to be free from all distortions. In reality, however, this never happens. On the right figure the refrigerator is tilted slightly to the left with respect to the plane of casters, while the doorway is assumed to be free of distortions. The resulting arrangement leads to interference.

You can imagine how specifying the “width” dimension limits alone can put fit ability in jeopardy. The homeowner who wants to assure fit using dimension limits must also specify or explain to measure the width correctly as shown in Figure 1-5.



**Figure 1-5. The width of the refrigerator must be measured in a way that is meaningful for fit**

Of the three methods of measurement shown, only the 840 mm value is functionally correct for fit. The other two measurements, albeit both reasonable measurements of the “width” of the refrigerator, lead to incorrect values for fit. A tolerancing scheme based on dimension limits simply ignores the reality that parts can have deformations and distortions. You may describe the required method of measurement by notes but the GDT standard provides an elegant way of describing exactly such a fit requirement using a compact symbolic notation.

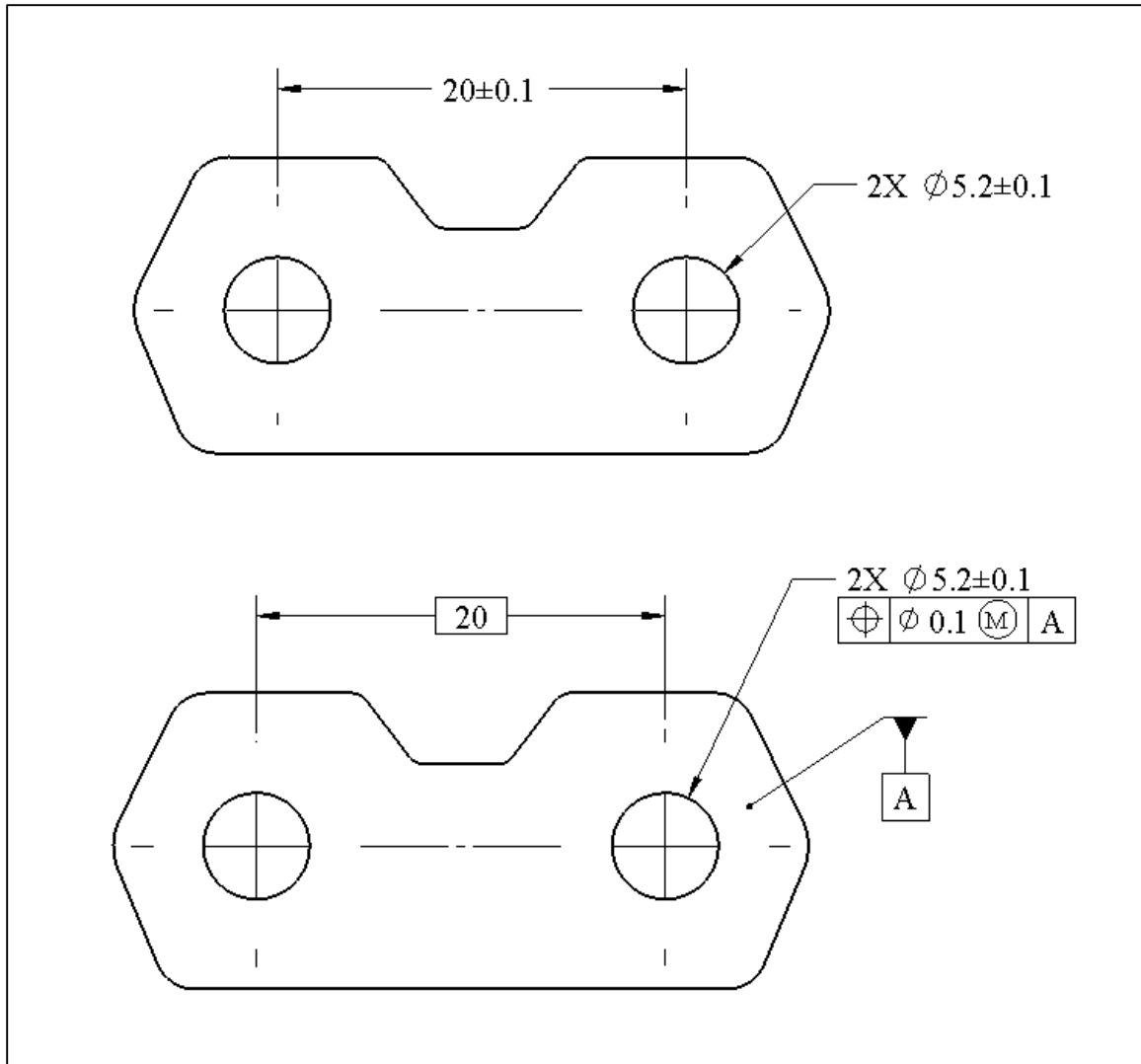
By making gages, the dimensional measurement confusion would never happen. The gage for the refrigerator would be a perfect 835 mm doorway as high as the refrigerator and made nearly perfectly with gage-making tolerances. If the refrigerator passes through this gage properly, it would also pass through the real doorway. Note that the gage geometry description by itself is not sufficient to assure a correct fit. The gaging instructions are necessary to ensure the refrigerator passes through the gage while casters are in contact with the floor. The GDT standard provides a set of symbols to easily describe the gages and the gaging methods for common fit applications in assemblies. The strength of the GDT standard specifications is that it allows a designer to specify the

precision needs of a part by following and mimicking the way the part is intended to fit into an assembly.

Unlike dimensional tolerances, geometric tolerancing statements do not ask for any numerical measurements at all. They simply describe the geometry of the necessary gages to assure fit and function. Of course an inspector who does not want to build a gage, for cost or practical reasons, is forced to make the necessary measurements to be able to judge with confidence whether the feature would pass such a gage if it had been made. In the case of the refrigerator, the inspector may easily measure the width of 830 mm and also measure the angle of tilt. Combining the two measurements would come close to the functional dimension of the refrigerator.

In design, the basic elements of function are features. Features are collections of surfaces that, as a whole, can be associated with a particular function. This is similar to the use of language in which the basic elements of communication are words not individual letters. A feature-based geometric specification language directly deals with features and their functions. The geometric tolerancing standard provides this feature-based language and a gage-based methodology for geometry control. Geometric tolerancing allows the design engineers to separately control various geometry aspects of features when needed. Such aspects include feature size, form, orientation, and location.

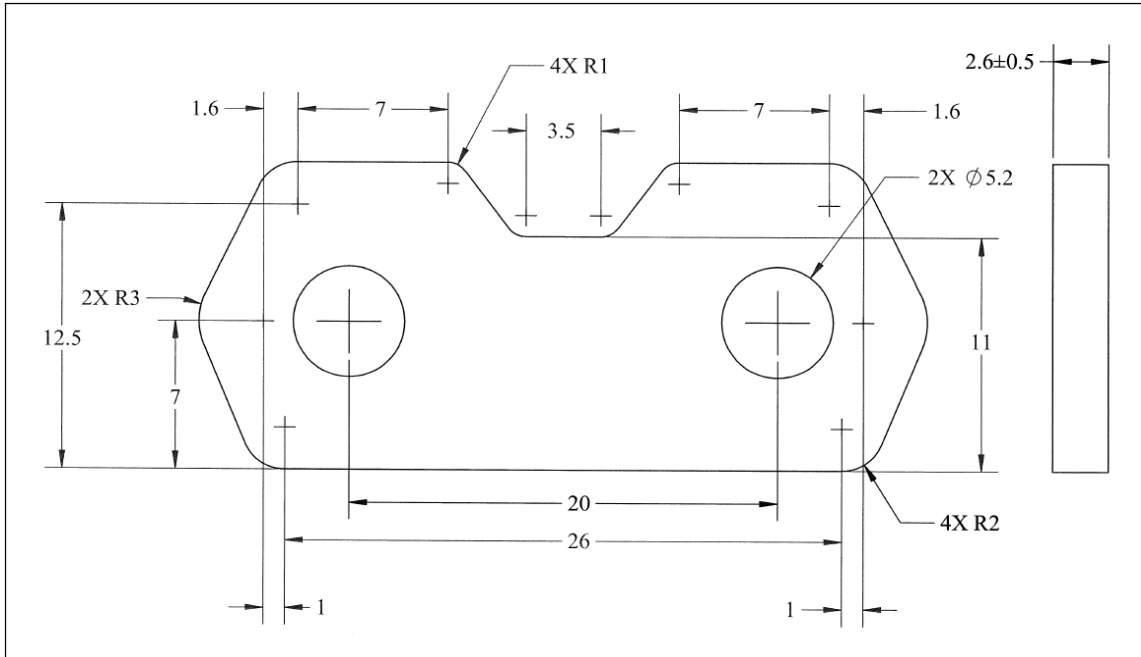
Today, the preferred method of specifying acceptable manufacturing tolerances is a combination of geometric and dimensional tolerances. Dimensional tolerances are mainly used to describe size limits of cylindrical features or width features (slots and rails). Figure 1-6, for example, shows both the dimensional and the geometric tolerancing methods of controlling the size and the distance between two holes. The geometric method will be explained later in detail.



**Figure 1-6. Specifying the tolerance on the distance between two holes using dimensional tolerancing (top) and geometric tolerancing methods (bottom)**

The two schemes both control the size and distance between the two holes but they do not have the same meaning. The specification shown in the bottom figure is functionally more meaningful and preferred to the method shown on the top figure. The details will be presented in later chapters.

Figure 1-7 shows the dimensions necessary to define the geometry of the chainsaw link previously discussed. In a tolerancing scheme based on  $\pm$  limits on dimensions, each dimension needs to have an associated tolerance either explicitly or implicitly through default tolerances in order to create a production drawing. The chainsaw link requires a lot of  $\pm$  tolerances to be fully toleranced. Except for the plate thickness tolerance, these tolerances are not shown on this figure because the drawing becomes difficult to read.



**Figure 1-7. The chainsaw link dimensions**

Figure 1-8, on the other hand, is a complete tolerancing scheme using feature-based geometric tolerancing specifications. Notice that only two dimensions are toleranced using  $\pm$  values. The rest of the dimensions are not shown because they are theoretical design dimensions and available in the CAD model of the part and can be automatically inserted into the drawing. The details of this tolerancing process will be presented in the later chapters but the fact that a design engineer need not break down features into surfaces and pay attention to every single dimension of a part is a significant time saver.

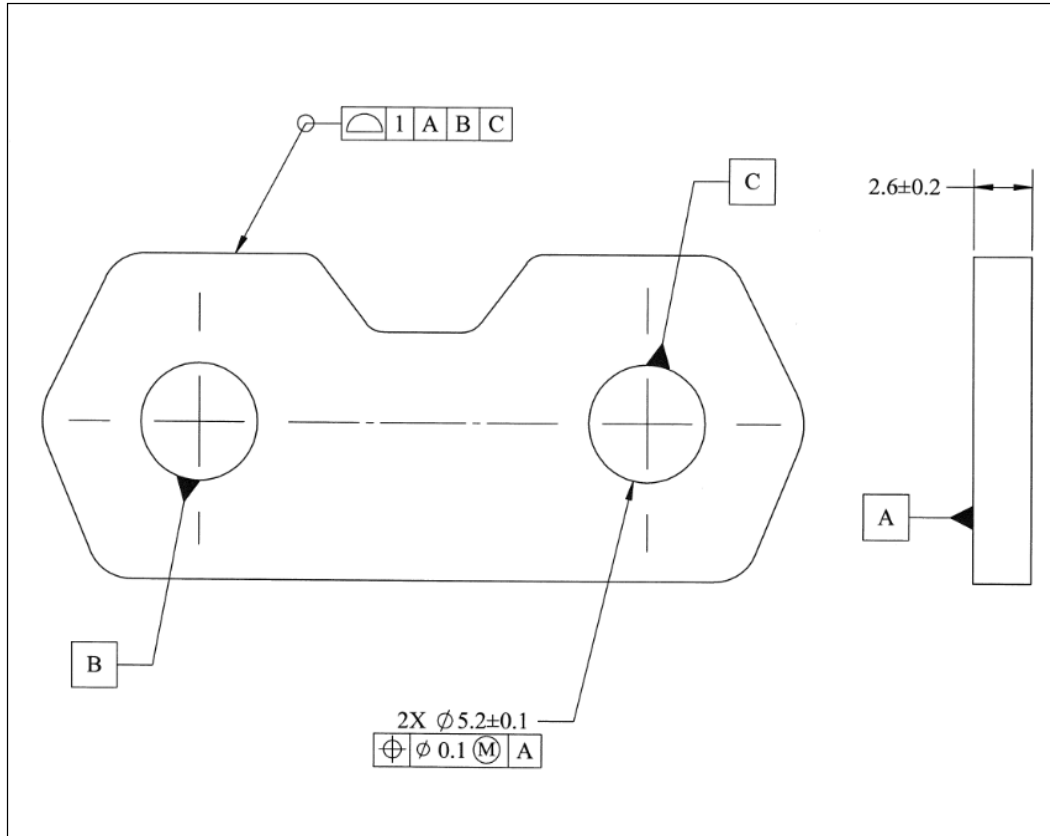


Figure 1-8. The chainsaw link fully toleranced with geometric tolerances

Geometric tolerancing promotes a feature-based and functional approach to tolerancing and allows a design engineer to control feature size, form, orientation, and location with varying degrees of precision as needed for fit and function. For example, in a feature-based way of thinking about tolerances, the chainsaw link has only three functional features. The first feature is the entire outer profile and is controlled with a single tolerance statement with low precision. The second feature is the pattern of two holes controlled by another geometric tolerance statement at high precision. The third feature is the plate thickness controlled by a dimensional tolerance at medium precision.

#### 1.4. Importance of clear geometry communication practices

Design engineers communicate the theoretical shape of parts to manufacturing through dimensioning. While the complete geometry of a part can be accessed through its 3D CAD model without effort, the use of 2D drawings is still quite common for geometry communication. It is perfectly fine for production to only create the tolerance requirements of a part along with the CAD model describing the theoretical geometry of a part. Note that a paper drawing is a legal document that can be used to settle quality disputes. The rest of this chapter is mainly for readers who need to be able to create high-quality 2D drawings. CAD systems can also create 2D drawings automatically from the parameters and dimensions entered during modeling. If care is exercised to model the

part using the dimensions that are intended to be on the final drawing, then little work remains after the CAD system generates the 2D drawings automatically.

Poorly dimensioned parts can lead to incorrect geometry interpretations or delays due to the need to clarify vague or missing information. Part drawings are not just to communicate information to manufacturing as design engineers often discuss the merits of different design alternatives using 2D dimensioned drawings as well. Poorly dimensioned parts reduce the effectiveness of design work as well. Today, the old engineering graphics courses are quickly disappearing as a part of the mechanical engineering curricula, replaced by 3D solid modeling classes. The lack of basic graphics training has led to new design engineer's inability to create well-dimensioned parts. Improper dimensioning often leads to frequent conflicts with manufacturing personnel.

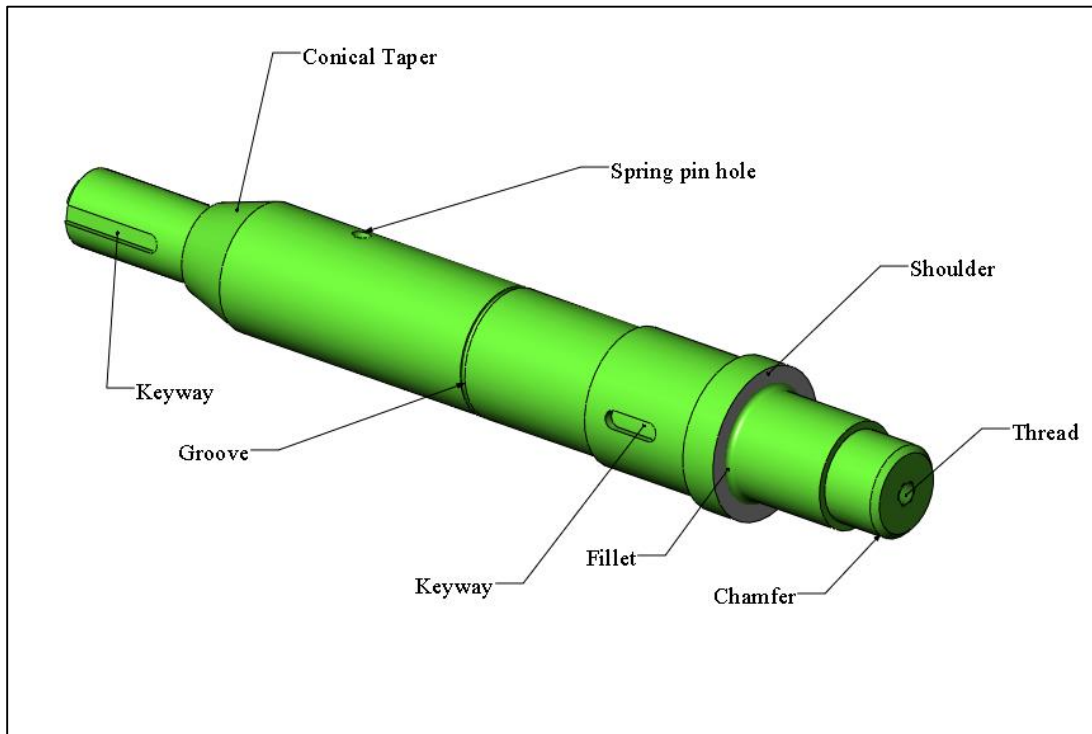
A well-dimensioned part drawing is like a well-written report. Good writing is about conforming to good writing principles that give a reader easy access to the information presented in a report. Likewise, a well-dimensioned part drawing presents the geometry of every part feature in a format that is easy to understand completely and quickly. As a badly written report is often an indication of poorly-understood ideas, a badly dimensioned part drawing is often a sign of poorly-understood fit and function needs.

To avoid unnecessary communication problems with manufacturing and others, design engineers should learn the simple rules of good dimensioning practice and develop the habit of delivering high-quality drawings to manufacturing and other design engineers. At first, conforming to good dimensioning rules may appear burdensome but with practice the methods become natural, intuitive, and easy to follow. The ability to conform to good dimensioning practices is also helpful in adhering to good tolerancing practices.

A lazy approach to dimensioning is to take a part drawing and randomly add dimensions to it until it is fully defined. This approach often leads to under-defined or over-defined parts with information scattered without any logic or organization. This method conveys little understanding of fit and function needs. A better approach to dimensioning is to recognize that each part is made up of a collection of features. Each feature (or feature pattern) can be described by a set of dimensions that define the shape of the feature itself and a set of dimensions that locate the feature with respect to other part features. In this respect, the word "feature" refers to a collection of part surfaces with a particular function. The function need not be precision as long as the feature has a particular purpose.

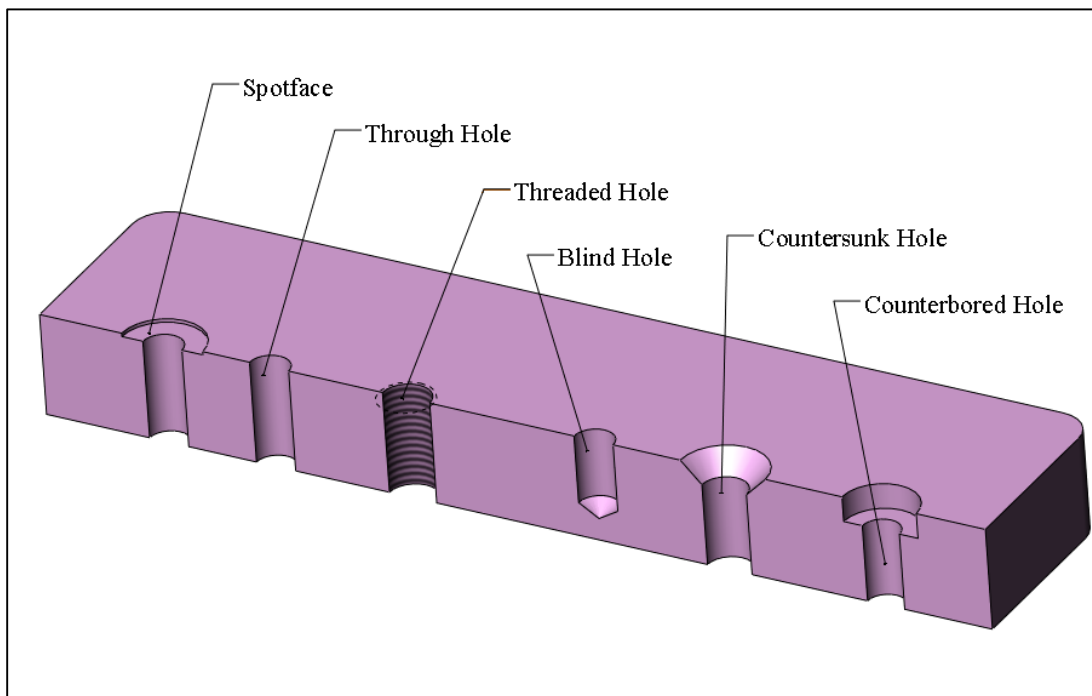
## **1.5. Functional feature vocabulary**

It is helpful to use the proper feature vocabulary when dimensioning or communicating geometry information to other engineers. Figure 1-9 shows the typical features of a shaft in power transmission applications. Using a functional feature vocabulary helps thinking in terms of features and not just individual surfaces.



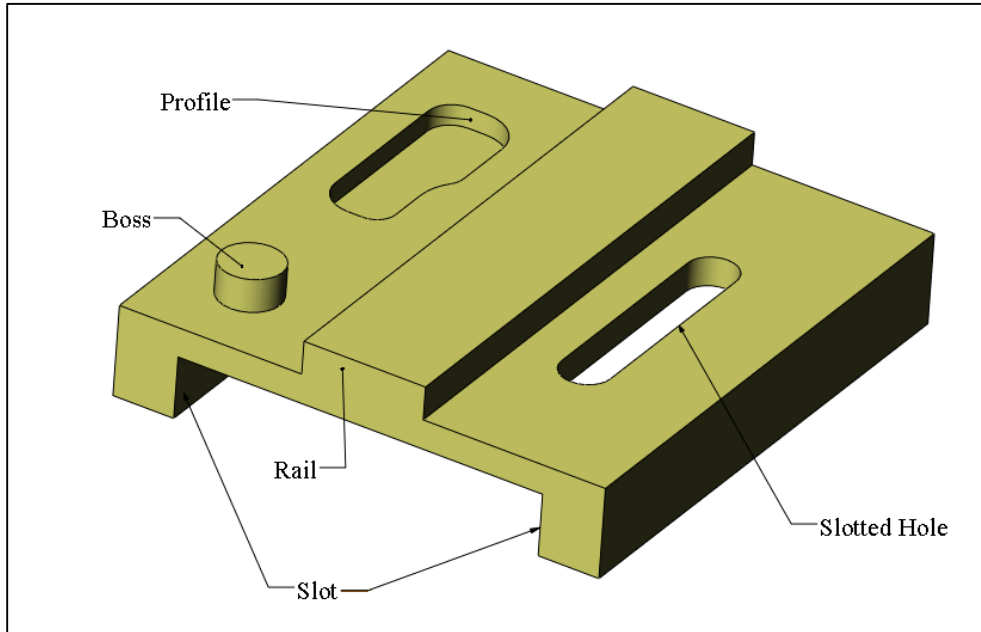
**Figure 1-9. A transmission shaft with its associated functional features**

Grooves and holes are often used with other identifiers such as snap-ring grooves or spring pin holes. Common features associated with fasteners are shown in Figure 1-10.



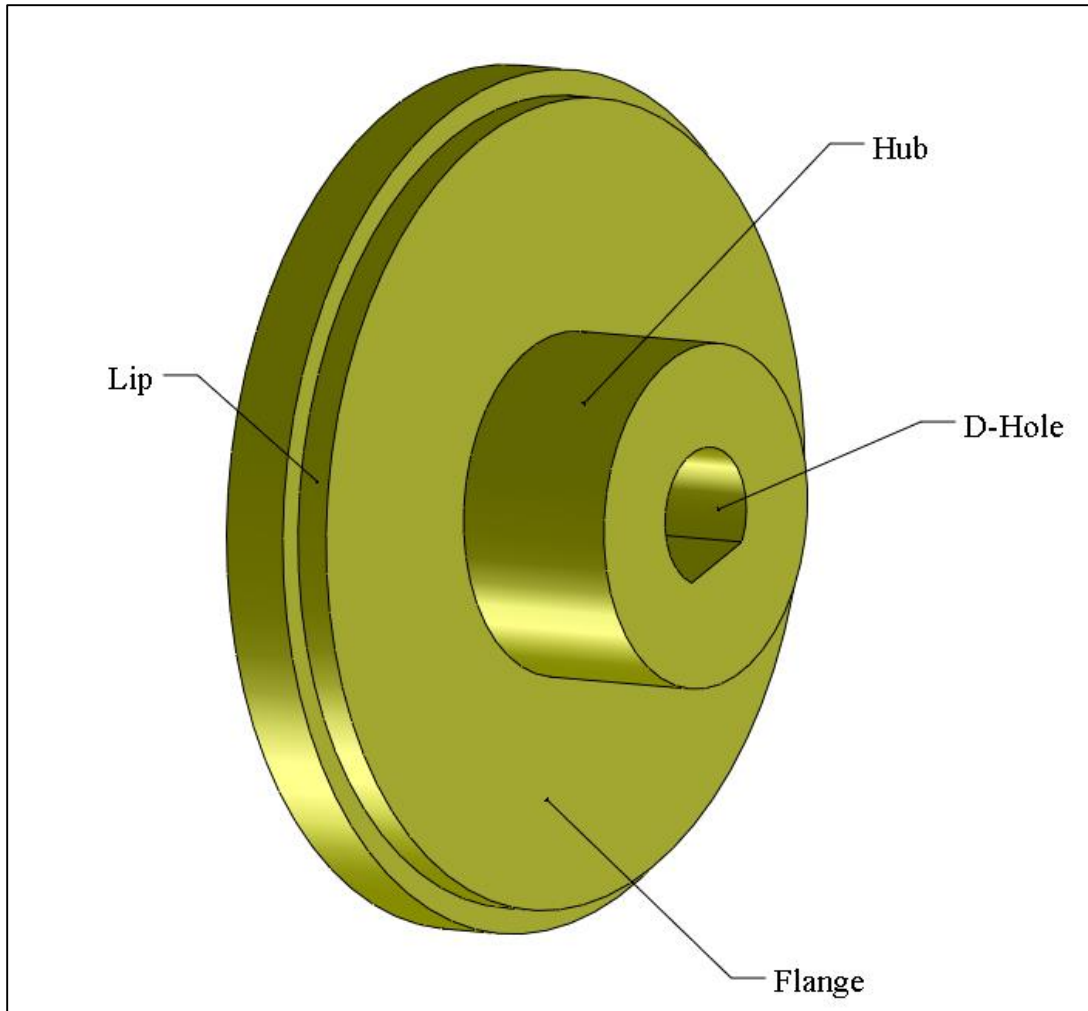
**Figure 1-10. Various kinds of fastener-related features**

Figure 1-11 shows some other common features on plate-like parts. A boss is a short raised surface of any shape. A profile is any combination of surfaces grouped together for functional and tolerancing purposes. Profiles can be internal (pockets) or external.



**Figure 1-11. Other common features of plate-like parts**

Figure 1-12 shows some of the common features of parts that usually fit onto rotating shafts.



**Figure 1-12. Common features of parts used with rotating shafts**

The hub is the bulky part in the center of a wheel or a gear. The flange is the relatively thin disk attached to a hub. A D-hole is a hole with a flat face that fits into a D-shaped shaft for torque transmission. A lip is a small recess that fits a mating hole to create a fit with minimal play.

Figure 1-13 shows a shaft with several geometric features in addition to the main cylindrical shapes. A good approach to dimensioning this part is to recognize its functional features and completely dimension each feature's internal geometry and location until no features remain. Thinking like manufacturing, a feature that is fully dimensioned is like a feature that is fully made. It is a good practice to check every feature of a part to make sure they are properly defined before sending the drawing to manufacturing. It is also a good practice to change your role and see the part as a virtual machinist who is going to make the part you designed. When dimensioning the part features, complete a feature's dimensioning before going to the next one.

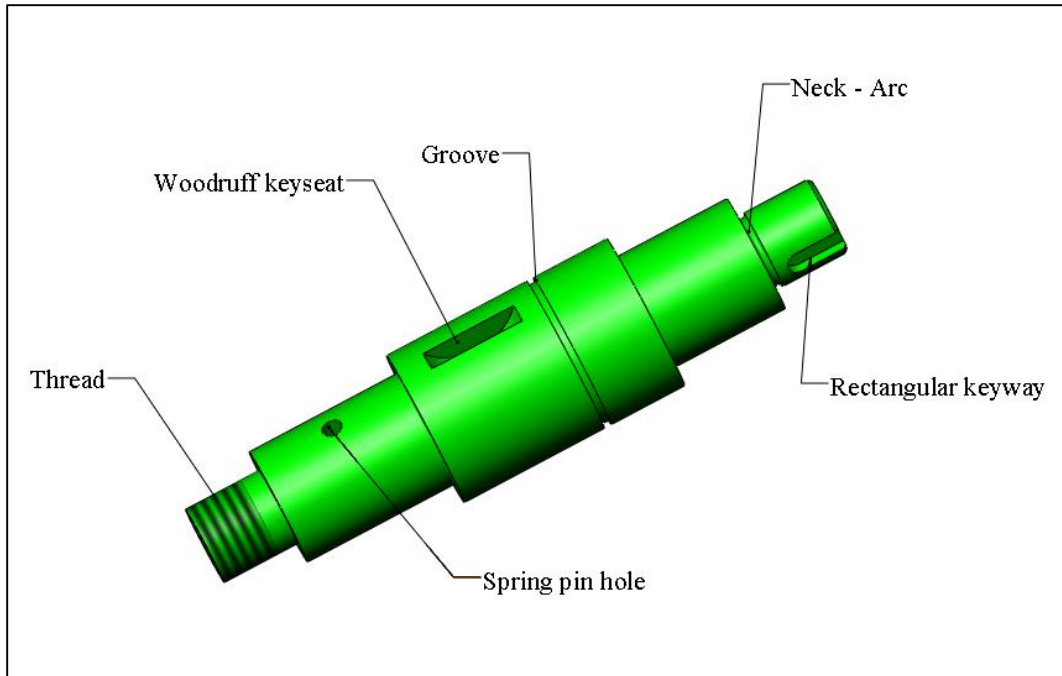


Figure 1-13. A transmission shaft with its associated functional features

A neck is a groove between two different shaft diameters. The drawing and dimensioning for this part will be presented later in this chapter. The next section presents the necessary guidelines to create well-dimensioned parts.

## 1.6. Preferred practices in dimensioning

Most of the rules of dimensioning are developed to communicate complete geometry information clearly with minimal clutter. It is emphasized again that a drawing should not be viewed as a collection of lines and curves but as a collection of features. Once every feature is properly dimensioned, the dimensioning task is complete. The drawing reader should not only find all the necessary information to construct each feature of the part but find them easily and quickly where he/she expects them to be placed. If you have had no drafting training I suggest that you visit some web sites where more drafting rules and examples are presented.

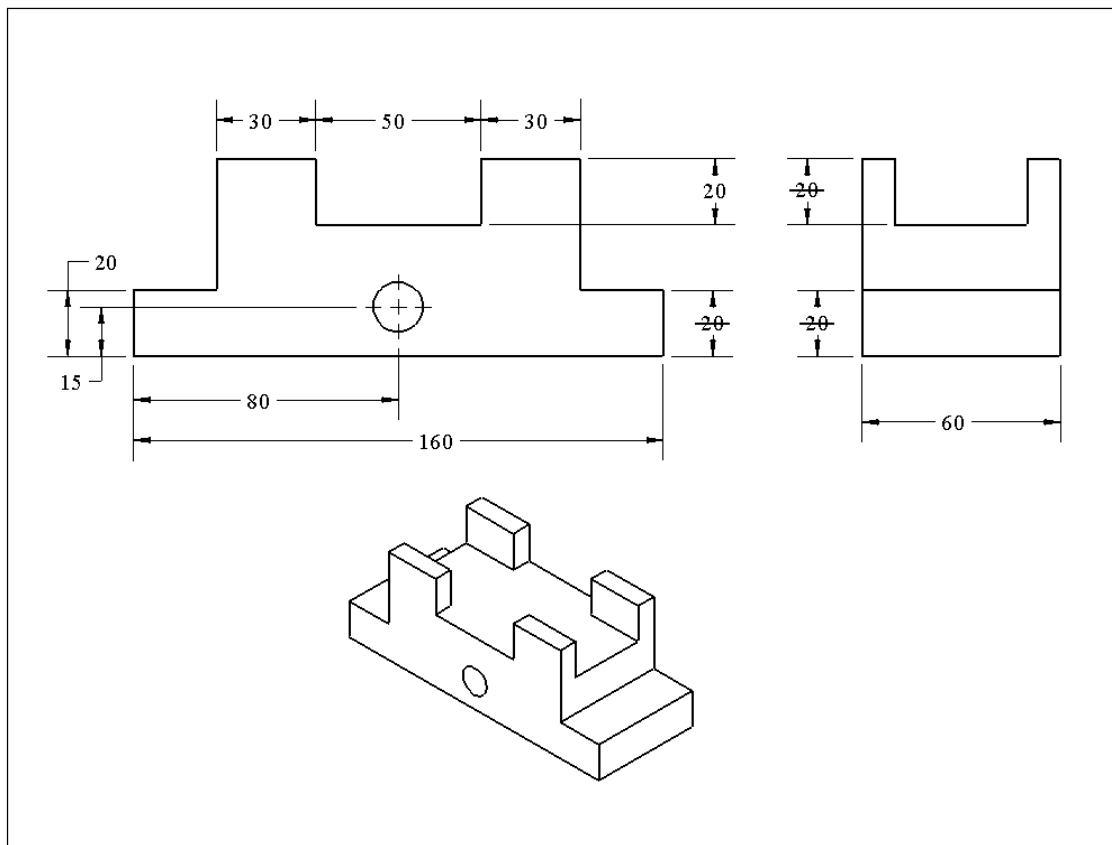
In order to reduce the number of needed dimensions, the following geometric relationships are true in a part drawing. When no information is provided to indicate otherwise, the following relationships are implied:

- Lines that appear to be perpendicular are perpendicular.
- Lines that appear to be parallel are parallel.
- Lines that appear to be collinear are collinear.
- Lines and curves that appear to be tangent are tangent.
- Cylindrical features that appear to be coaxial are coaxial.

Lines mentioned in the above rules also include the centerlines connecting the features of a pattern, such as a pattern of holes, whether such connecting lines are shown or not. The following geometric relationships are *not* implied when left unspecified.

- Lines that appear to have equal lengths are not implied to have equal lengths.
- Diameters and radii that appear to be equal are not implied to be equal.
- Features that appear to be symmetrically located with respect to a center plane or axis are not implied to be symmetrically located unless other information is provided.

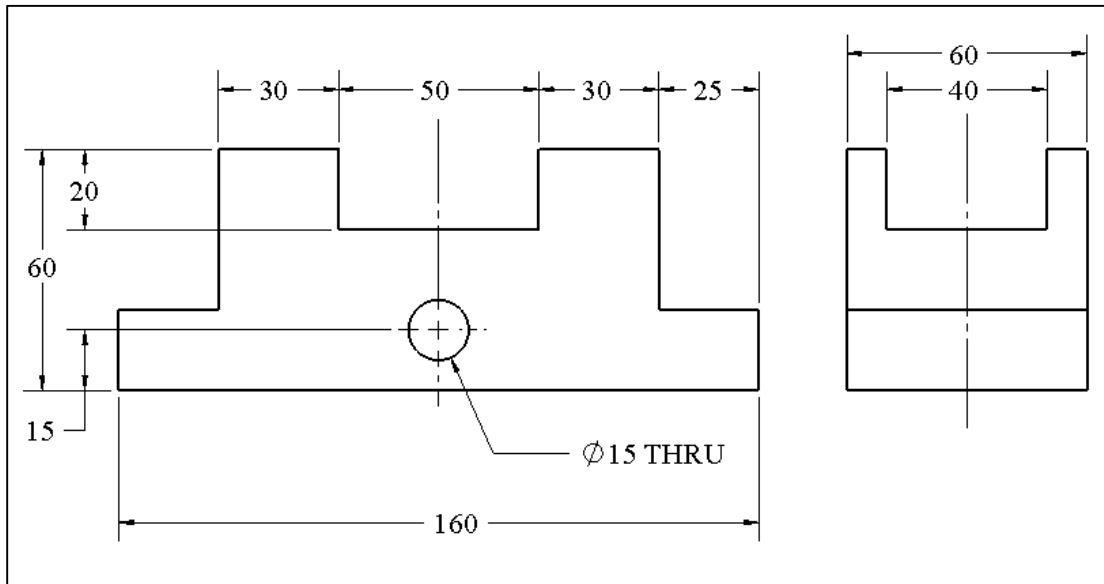
Figure 1-14 illustrates some of the above rules. The dimensioning of this and other example parts shown in this section may not be complete to better illustrate certain key points.



**Figure 1-14. Avoid double dimensioning. Lines that appear collinear are collinear**

The crossed out dimensions represent repeated dimensioning and should be removed. The 30 mm dimensions are both necessary as the appearance of equal length lines does not imply equal length lines. Similarly, the hole feature appearing in the middle of the part does not imply that it is in the middle and must be located both horizontally and vertically. If the 80 mm dimension is not shown, as in Figure 1-15, then the center plane of another feature should be shown to imply that the hole axis is aligned with the center plane of another feature. A geometric tolerance statement would also be necessary to

identify which feature the hole is aligned with as multiple features may qualify. The procedure for applying such tolerances will be presented in later chapters. It is worth noting that centering or alignment implies a dimension of zero which is not shown on a drawing. Therefore, in strictly dimensional +/- tolerancing, there is no ability to indicate how precisely the features are to be centered or aligned. Fortunately, that is not a problem in geometric tolerancing. The side view also shows that the 40-mm slot is to be centered to the 60-mm outer rail feature. A tolerance statement is necessary to show the level of centering precision. If in the side view a dimension of 10 mm is shown then the center plane lines should be removed.



**Figure 1-15. Extended centerlines should be drawn to indicate that a feature is centered with respect to another feature**

A smaller scale 3D view is often added to a drawing but the drawing interpretation must not rely on such 3D images. Three dimensional models can be dimensioned but the practice is not uniform or widespread. In this book dimensions are not shown on 3D models or assembly drawings. This book uses the 3<sup>rd</sup> angle projection format which is commonly used in the United States.

Views that are not needed should be removed. You may insert additional views that you feel would be needed to correctly interpret the drawing or to provide additional dimensions. However, adding unnecessary views and dimensions may reduce the readability of a drawing.

When creating drawings you are expected to adhere to other rules and preferences listed below. Not following these rules usually reduces the efficiency of graphical communication. However, there are always cases where deviation from stated preferences may be justified. The most important rule is to provide a complete and clear description of part geometry.

## General Rules and Preferences

1. In the United States the American National Standards Institute (ANSI) drafting display format is preferred. This standard formatting controls all the display details such as the display of dimension text sizes, notes, line thicknesses, line formats, and symbol sizes. All dimension text and notes are to be horizontal. The CAD system will do this automatically when ANSI format is selected.
2. Draw and dimension the entire part. The use of the symmetry symbol to reduce the number of required dimensions is not a preferred practice.
3. Select a front view that best shows most of the important features of the part. When necessary, other views (top, bottom, right, left, and rear) are to be placed around the front view. The views must align and have the same scale.
4. Decimal millimeter values are used for dimensions in this book. When a value is less than one millimeter, a zero is to be shown before the decimal point. Trailing zeroes, however, are to be avoided.
5. Avoid odd dimensions or unusual precision unless well-justified. Most part dimensions can be adjusted slightly to make them more rounded. Using extra figures of accuracy where they are not needed would make the part more costly to make. A simple number rounding rule will be presented later in this chapter.

Figure 1-16 shows a part with three dimension specifications. Unusual and unnecessary precision should be avoided and the trailing zeroes should not be shown.

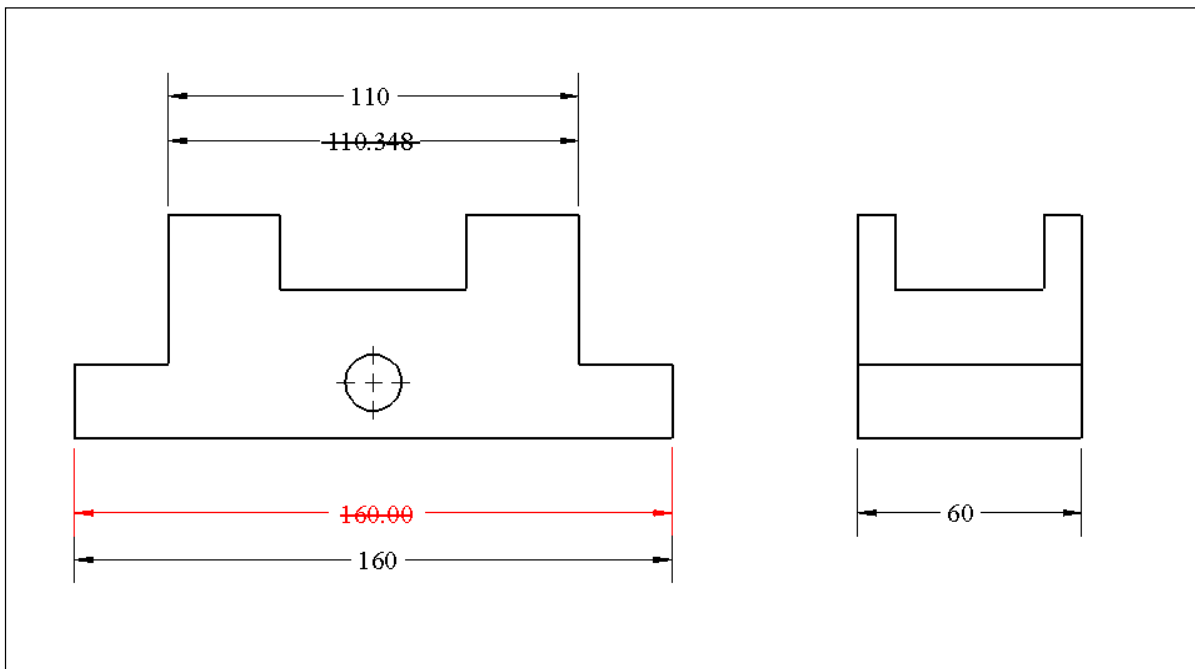
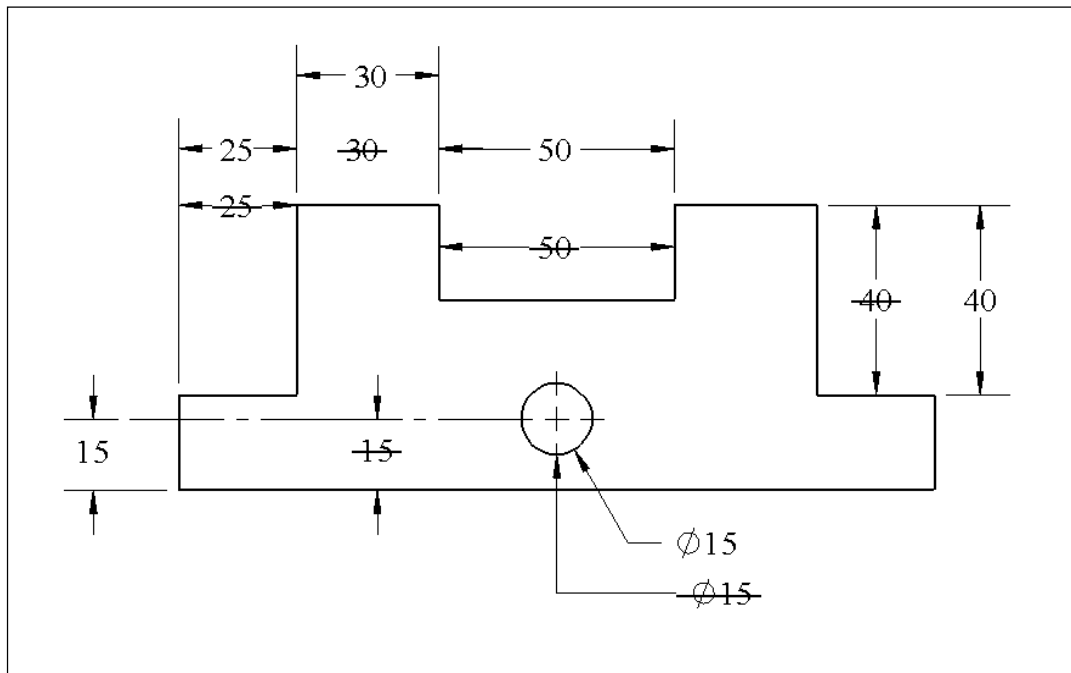


Figure 1-16. Avoid unusual precision or trailing zeroes

## Dimension and Extension Lines

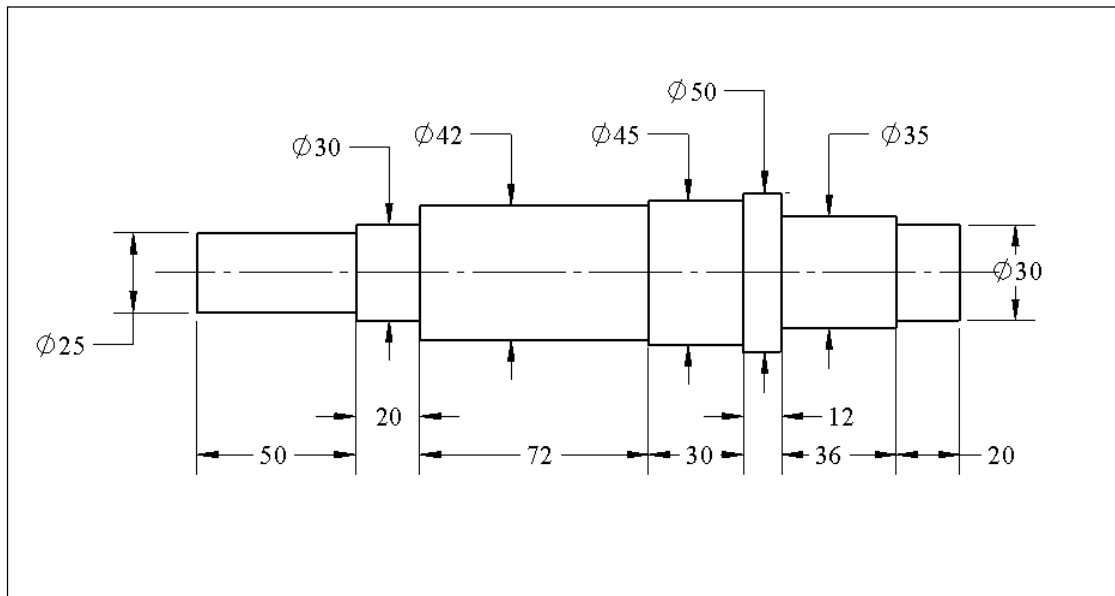
- Do not use an existing line as a dimension line. This includes part profile visible lines, continuation of visible lines, hidden lines, centerlines, or extension lines. All dimension lines must be separately drawn.
- Place dimension values centered between the arrows when there is sufficient space between the arrows.
- Place dimension lines so they do not intersect.
- Each dimension line must have its own end arrows. Arrows are not to be shared between dimensions.
- Avoid using part profiles as extension lines.
- When extending centerlines to be used as extension lines, use the centerline line format.
- Minimize intersection between dimension lines and extension lines. Also minimize intersecting extension lines.
- Point leaders to lines at an angle other than 0 or 90 degrees (preferably closer to 45 degrees).
- Leaders pointing to circular features are to be radial in direction.

Figure 1-17 shows examples of inappropriate placement of dimension values and use of part profile lines as extension lines.



**Figure 1-17. Place dimensions outside the part and do not use part boundary as extension lines. Do not share arrows between two dimension lines**

- Occasionally the part profile can be used as extension lines when separate extension lines become long and intersect many other lines creating confusion. A common example is in shafts with many features as shown in Figure 1-18.



**Figure 1-18. Using part profile as extension lines is preferred for shafts with several features**

The dimensions, however, are best to be placed outside the part profile.

## **Dimension Placement**

16. Place dimension text outside the part view boundary or at least outside the part outer profile box. When space allows, place dimensions between views.
17. When dimension lines are too close, stagger dimension values so the text is easy to read.
18. Align the dimension lines when possible. Note that each dimension must have its own dimension line and its own arrows.
19. Maintain a uniform distance of about one character height between parallel dimension lines. The closest line to the part profile is placed at a distance of about 1.5 character height.
20. Keep the dimensions that define a feature close together and close to the feature and preferably on the same view. The reader should easily locate all of the dimensions related to a feature.
21. When it is necessary to put words on the drawings they should be all capital letters. However, standard symbols have been developed to minimize the use of words – use words only when there are no symbols to convey the message. For example, the word THRU is commonly used to indicate clearance holes or cuts when section views or hidden lines are not used to show the feature depth.
22. Favor feature-based dimensioning in which dimensions define size and location of features. Identify the features, dimension their internal geometry, and then use functional dimensions to locate the entire feature with respect to other features.

## Repetition Symbol

23. Use the repetition symbol nX (such as 4X) for repeated features, preferably features that form a clear pattern and are countable on the same view. Do not use other text such as 4 PLCS or 4 HOLES, etc.
24. When features (referred to by nX) are not all visible on the same view, they should be clearly identifiable on other views. Common features for which nX is used are patterns of holes, bosses, slots, rails, fillets, and similar patterns.
25. Use nX when the referenced feature is clearly and uniquely identifiable, otherwise use separate dimensions.
26. Every feature count of nX must refer to a separate feature. The fillet that appears on the top and bottom of a shaft are the same feature and count as one.

Figure 1-19 shows a plate part with a pattern of four holes and a cross hole. Note that the use of THRU for the 6.6 mm cross holes is not appropriate because it is not clear whether the hole is through the first section of the plate or both. One may use THRU BOTH but the hidden lines are preferred here to indicate the extent of the cross hole. Also, the extended centerline on the side view indicates that the hole is centered relative to the thickness of the plate. The pattern of four holes is internally defined by 60 mm and 14 mm dimensions and then the pattern is located with respect to the left edges using 30 mm and 8 mm dimensions. The locating dimensions must be chosen to be functionally important. In this case the pattern location with respect the left face and bottom face are important.

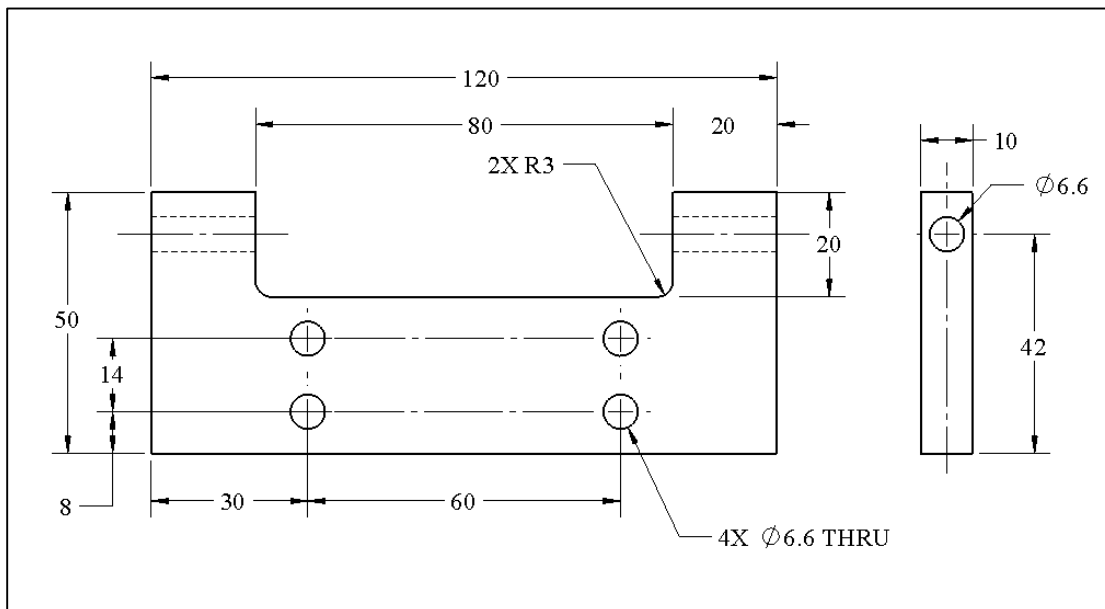
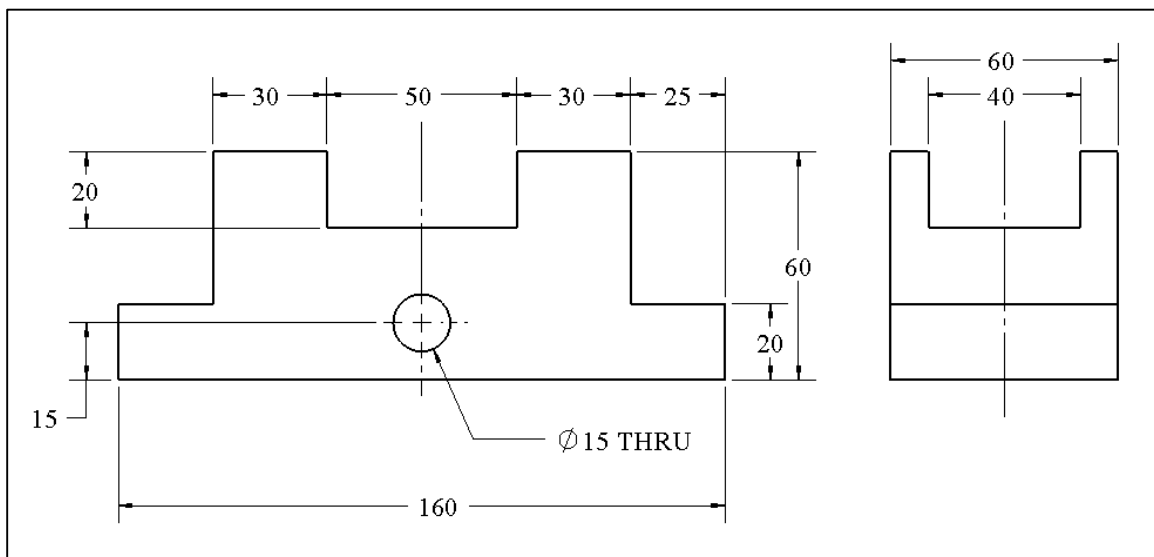


Figure 1-19. Dimensioning of feature patterns

27. Place all the related dimensions of a feature close to the feature, close together, and preferably on a single view. A person reading a drawing should mentally construct a feature quickly with one look.
28. Specify the important functional dimensions first. Never alter the functional dimensioning scheme of a part thinking that manufacturing prefers it in a different way. Manufacturing people are well-trained to find the best way to create the needed precision. Manufacturing method decisions depend on tolerances and not on theoretical dimensions. On the other hand, designers that discuss possible modifications of the design would like to see the most important and functional dimensions on the drawing.

Figure 1-20 shows some of the other dimensions for the example part shown earlier. When a dimension can be shown on two different views, select the view in which the dimension is easier to interpret. For example, the lower step height of 20 mm is easier to interpret on the front view than the side view.



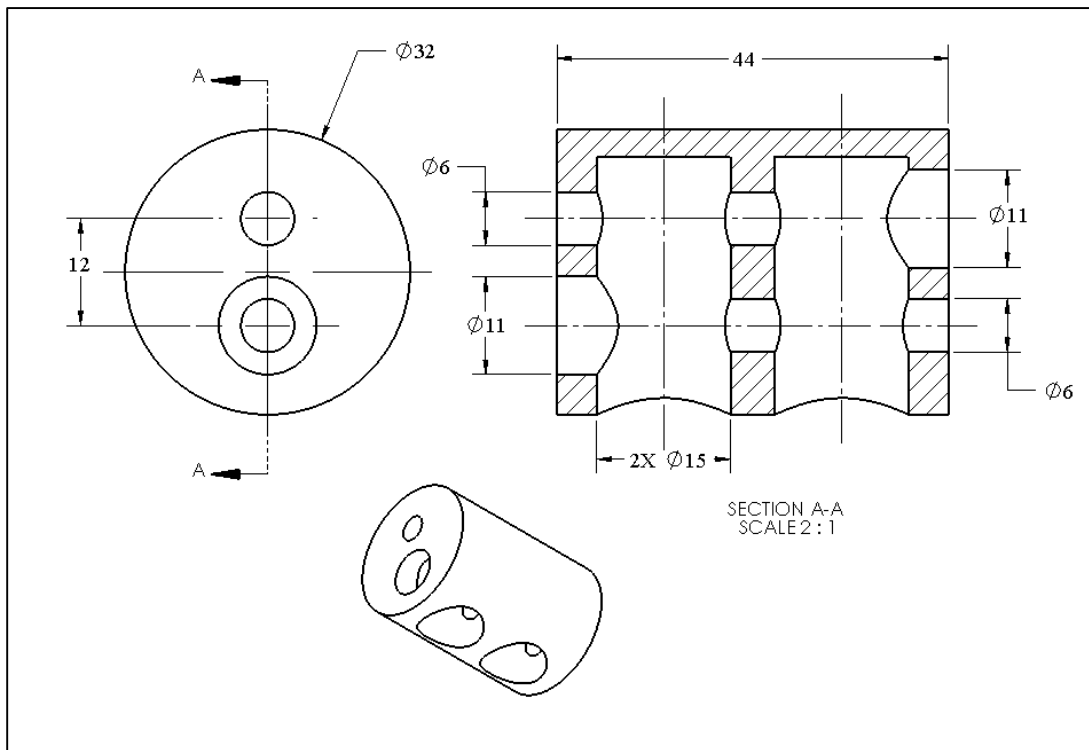
**Figure 1-20. Complete dimensioning of the part**

As mentioned before, the appearance of centerlines in the side view indicates that the slot feature is centered to the 60-mm thickness feature. Without the centerlines the part is not clearly defined. To avoid the appearance of missing dimensions a reference dimension can be applied when necessary. A reference dimension is a dimension in parenthesis. For example, a reference dimension of (80) can be added to the hole to emphasize that the hole location is defined by alignment.

29. You should avoid over-dimensioning or repeated dimensions for the same feature. Over-dimensioning means specifying a dimension or angle that can be calculated from the already specified dimensions and angles. In cases where it is not clear that two features have the same dimension, repeated dimensions can be used for clarity. Over-dimensioning, however, is not an error when used with geometric tolerances - it just makes the drawing busier.

30. Minimize the use of TYP which stands for “typical” unless the referenced features are obvious. A common application is for a part with a large number of fillets or rounds on its edges such as in molded parts.
31. Use section views to display internal features of a part, detailed views for small features, and cutout views for local hidden features.

Figure 1-21 shows a part with internal features best viewed as a cross-sectional view. Not all of the dimensions are shown on the figure.



**Figure 1-21. Internal features are best viewed by cross-sectional views**

32. Do not show tangent lines where a surface blends into another surface such as for fillets and rounds. An example is shown in Figure 1-22.

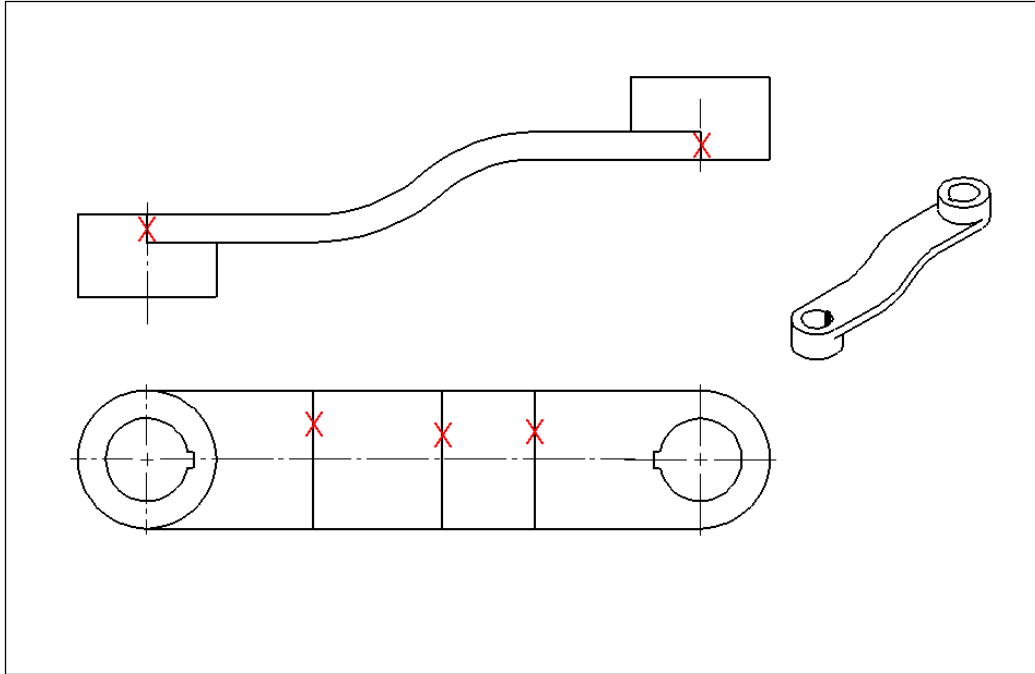


Figure 1-22. Do not show tangent lines

33. Use compact specification formats to efficiently dimension common features such as counterbored holes, countersunk holes, blind holes, chamfers, keyways, etc. In a compact format all of the feature dimensions are placed in the same spot.

The part shown in Figure 1-23 is a plate with a pattern of five countersunk holes, four chamfered edges, and a blind cross hole.

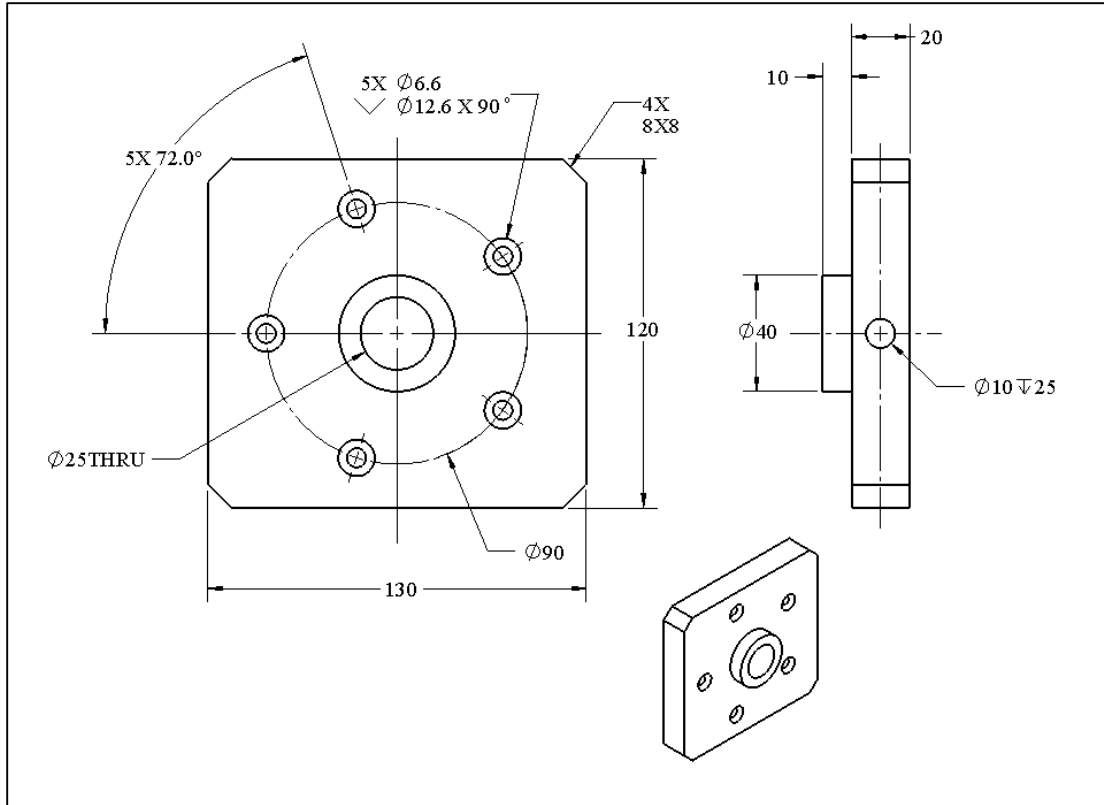
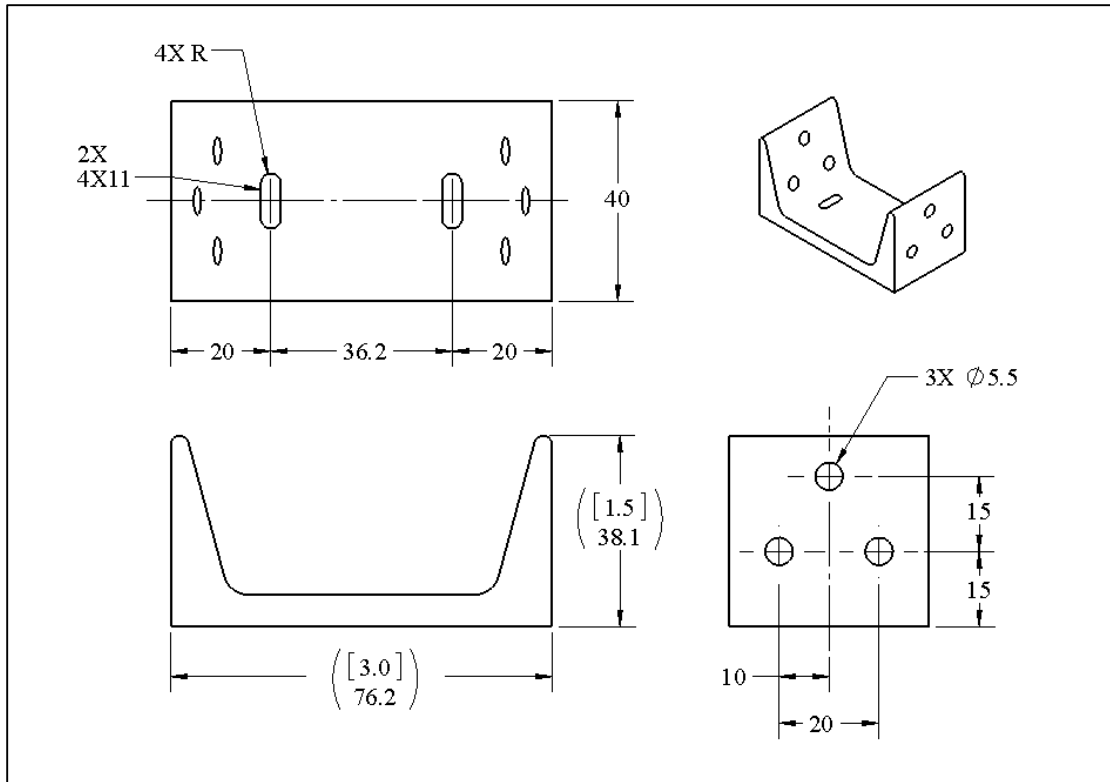


Figure 1-23. A plate with countersunk holes

The pattern geometry is defined by the diameter of the pattern circle and the number of holes and their angular separation. The pattern is located relative to the two side faces defining the width of the plate. The compact notation for holes is usually used for small holes and fastener holes.

34. Minimize the use of reference dimensions (dimensions enclosed in parentheses) which can be calculated from other existing dimensions. Reference dimensions are appropriate when they refer to identifying dimensions of standard stock or standard parts that are intended to remain as is. Reference dimensions can also be used when features are aligned and there is an appearance of missing dimensions.
35. Use dual dimensioning on features that have standard sizes in a different unit system than the one used on the drawing. Some companies require dual dimensioning for all dimensions.

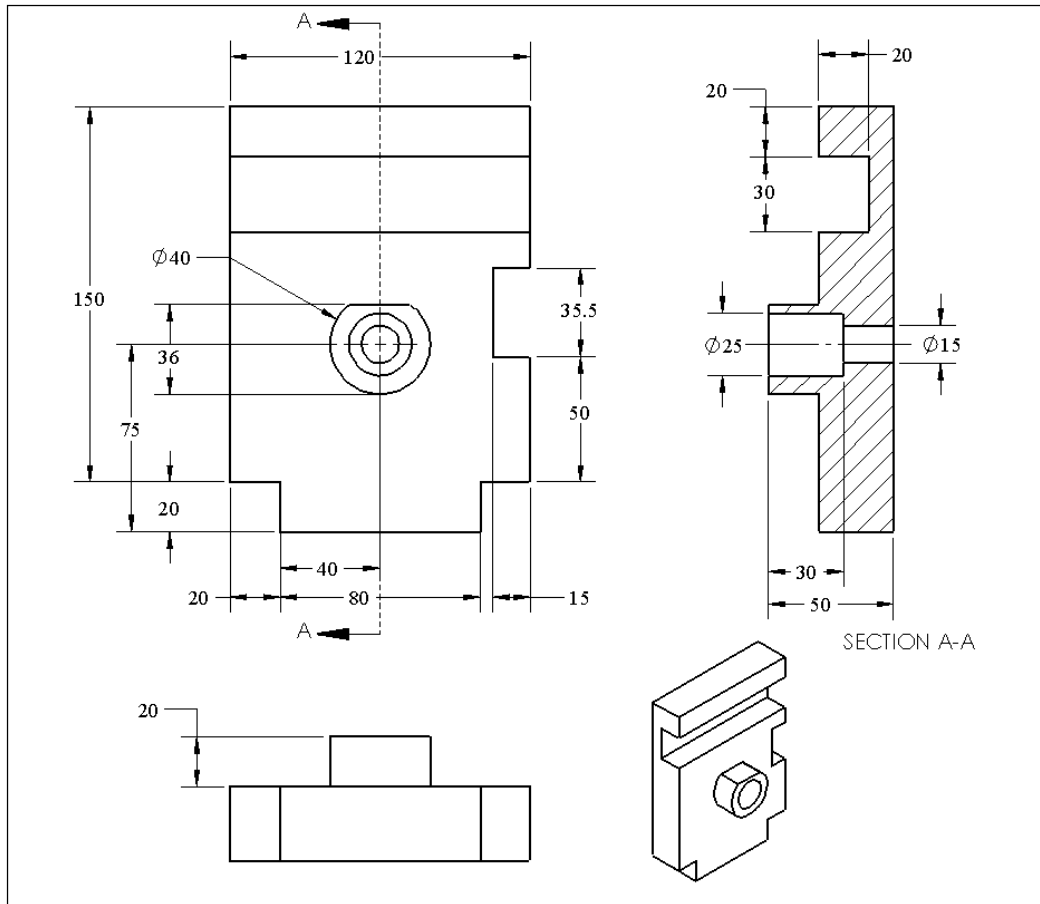
In the channel drawing in Figure 1-24, reference dimensions (3 inch by 1.5 inch) are used as identifying dimensions to indicate the channel standard size – these values are not to be altered. These dimensions are also shown in dual dimension format as inch units refer to the identifying dimensions. Also note the compact dimensioning scheme of the slotted holes. Search the internet for the “dimensioning of slotted holes” to see plenty of examples. You can also search the internet for compact dimensioning of other common features.



**Figure 1-24. Use of reference dimension and dual dimensioning on a standard C-channel**

36. When specifying threads, use the standard thread designations such as M6 x 1. Do not separately dimension the diameter of such threaded features.
37. Do not use process information to convey geometry information. For example, do not specify “USE 10-mm DRILL” in lieu of actual hole dimension limits. Also, do not use specifications that refer to standard parts like “CUT FOR #205 WOODRUFF KEY” as a substitute for specifying Woodruff keyway’s dimensions.
38. Show preference to dimensioning distances rather than angles. Angles are usually not shown unless the angle is functionally important.
39. Place feature dimensions on the views where the feature shape information is best seen. For example, when dimensioning the width of a slot feature, dimension the view in which it is clear whether the feature is a slot or a rail. When dimensioning the size of a cylindrical feature, place the dimensions on the view in which it is clear whether the feature is a hole or a boss.
40. Do not use center marks for fillets or arcs when no dimensions are necessary to locate their centers. Always show the center marks for cylindrical holes or bosses that fit other features and show the axis of cylindrical features.
41. When a partial cylindrical feature is used as a fit feature (i.e. something fits into that feature), use diameter dimension – otherwise use radius dimension.

Some of the points mentioned above are illustrated in Figure 1-25.



**Figure 1-25. Dimension slot and rail features in views where their depth can be seen**

Note that the slots and the rail are dimensioned in views where their depth can be seen. The slot and rail depths, widths, and locations are shown close together. The holes are dimensioned in the section view where the feature type, size, and depth can be seen together. The geometry of the D-shaped boss is shown in the profile view where the D-shape is best seen. The center feature is located to the bottom edge (75 mm) and to the edge of the rail (40 mm).

## **Pattern Dimensioning**

42. Use dimensions to fully describe the internal geometry of a pattern and then use dimensions to locate the pattern with respect to other functionally relevant features.
43. Connecting the centerlines of holes in a pattern is preferred but they can be implied and left out when the pattern lines reduce the readability of the drawing.

The part shown in Figure 1-26 has a pattern of four counterbored holes. The pattern is 170 mm by 55 mm and it is located with respect to the lower left corner edges. The pattern connecting lines are not shown in this case. The shape of the slotted hole is defined by its length (120 mm) and its width (15 mm) while its location is specified by its distance to the left face (40 mm) and the lower face (40 mm).

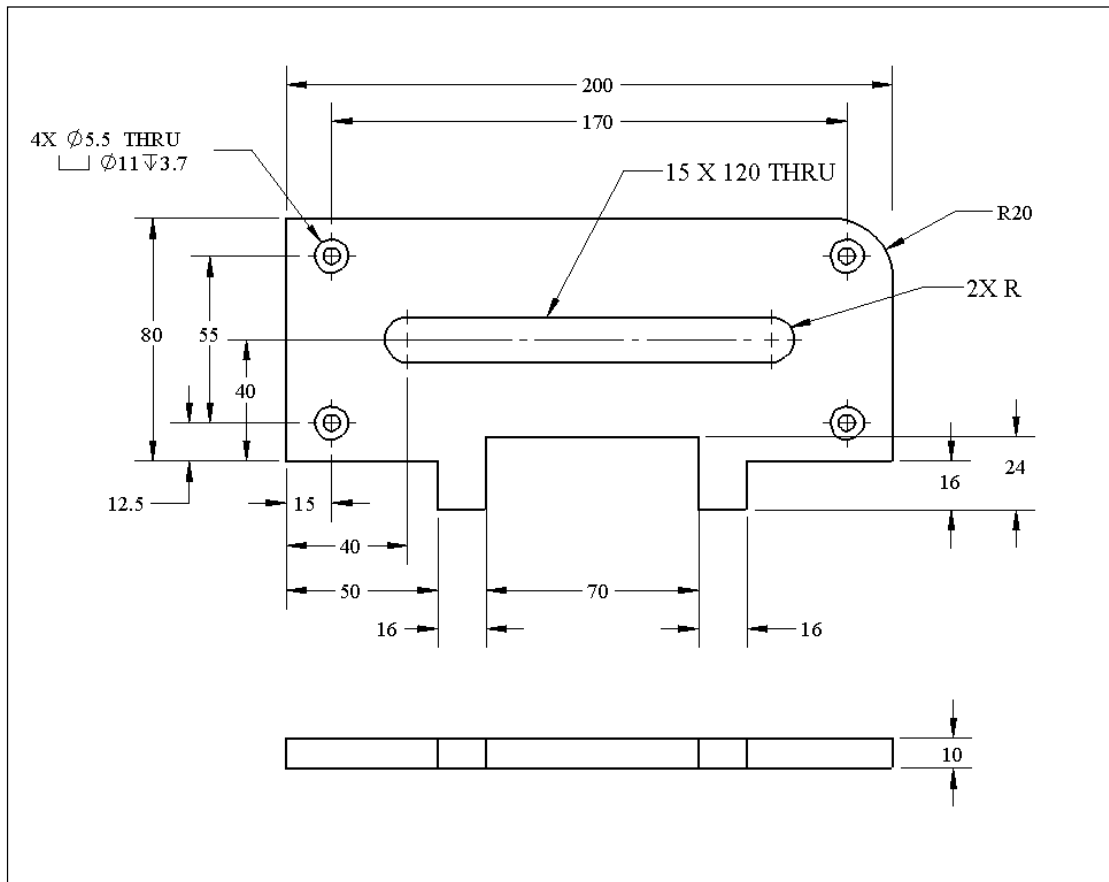


Figure 1-26. A plate with a pattern of counterbored holes

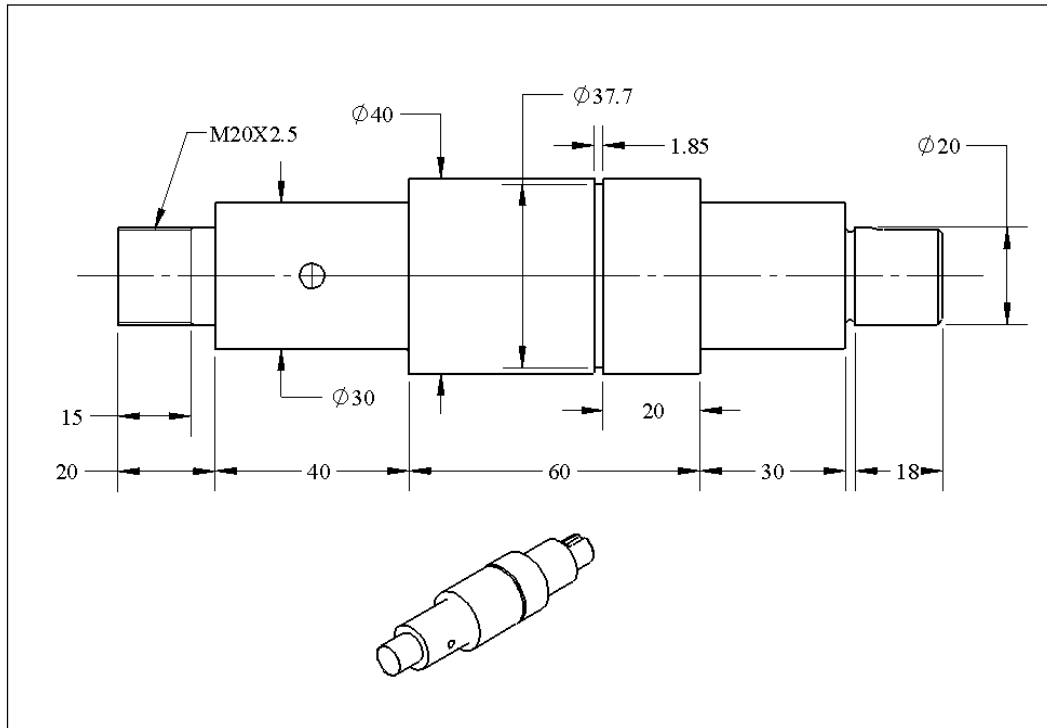
You can think of a feature pattern as a solid piece like a piece of furniture such as a dining table. When locating a piece of furniture we pick two edges and specify the distance of these edges to the walls with two numbers. The rest of the dimensions are defined by internal dimensions. Always use a minimum number of dimensions to locate a pattern.

### Hidden Lines

44. Do not show hidden lines unless they help show the extent of features not visible in other views. When required, only show the hidden lines for the necessary features.
45. Do not dimension to hidden lines unless it is clear and simplifies the dimensioning or when it reduces the number of views.

### Additional Examples

Figure 1-27 shows the first dimensioning step for the shaft shown previously. The shaft has a number of features associated with power transmission application. The first step is to describe the shaft diameters, lengths, and functionally important shoulder-to-shoulder distances.



**Figure 1-27. Dimensioning of shaft diameters and shoulder-to-shoulder distances**

After the dimensioning of the shaft diameters, including the left threaded diameter, the other features need to be dimensioned. Each feature should be identified and completely described before going to another feature. The first two selected features are:

- The rectangular keyway on the right end of the shaft
- The shaft neck close to the rectangular keyway

Figure 1-28 shows the necessary views to dimension the rectangular keyway and the shaft neck. The width and depth of the keyway are described in the V-V section view while the length is shown in the top view. The neck detail is shown in a detailed view for clarity. To save space the detailed view and section view are not labeled.

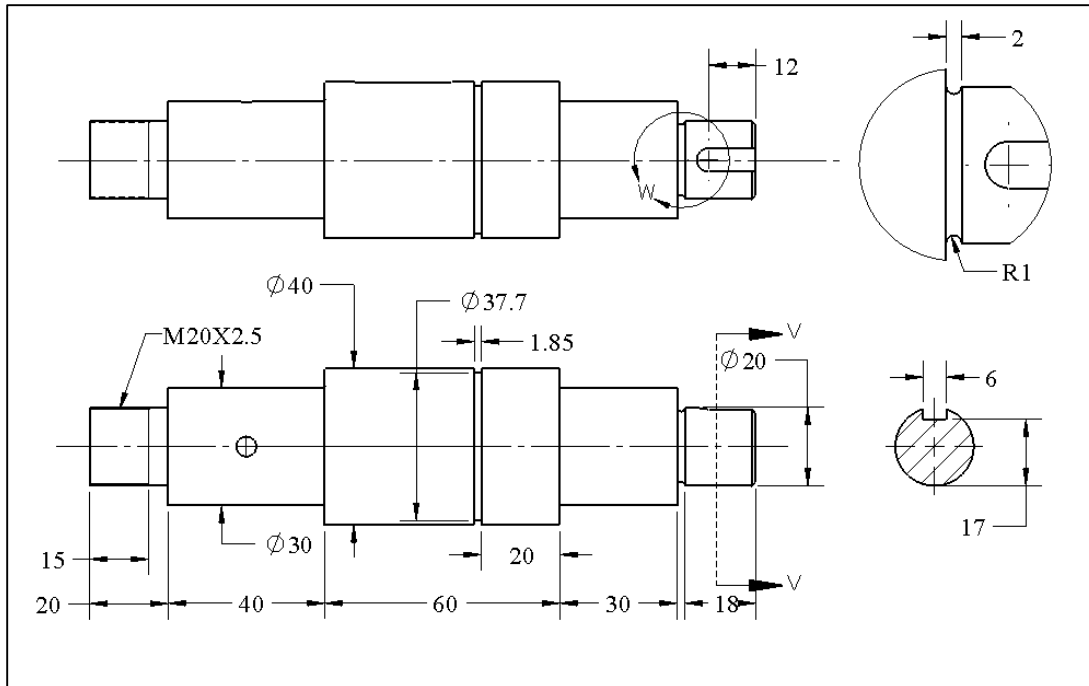


Figure 1-28. Dimensioning of the rectangular keyway and the 2 mm wide neck

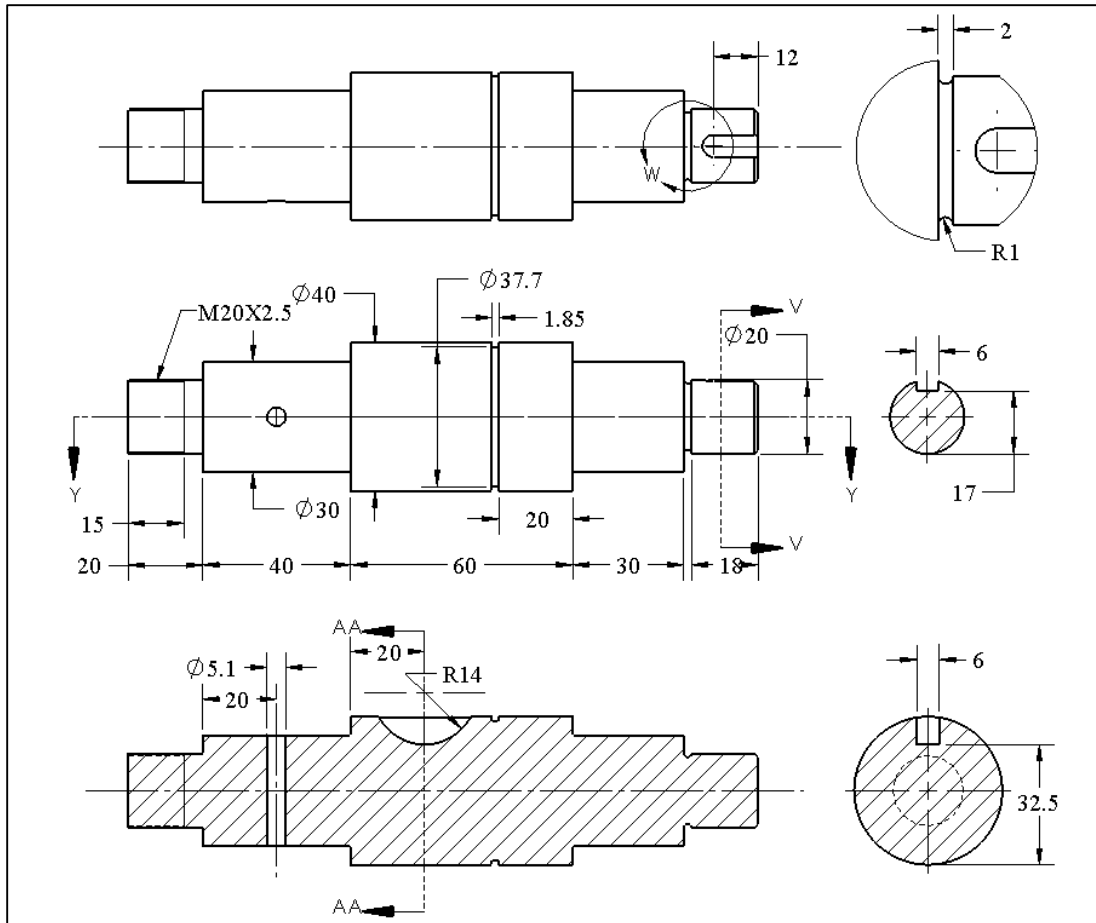
Note that the center plane of the keyway slot coincides with the axis of the shaft. This means the two features are aligned. We can also show the 3 mm distance between the edge of the slot and the center lines.

Two additional features of the shaft are:

- The cross hole for a spring pin
- The Woodruff keyway

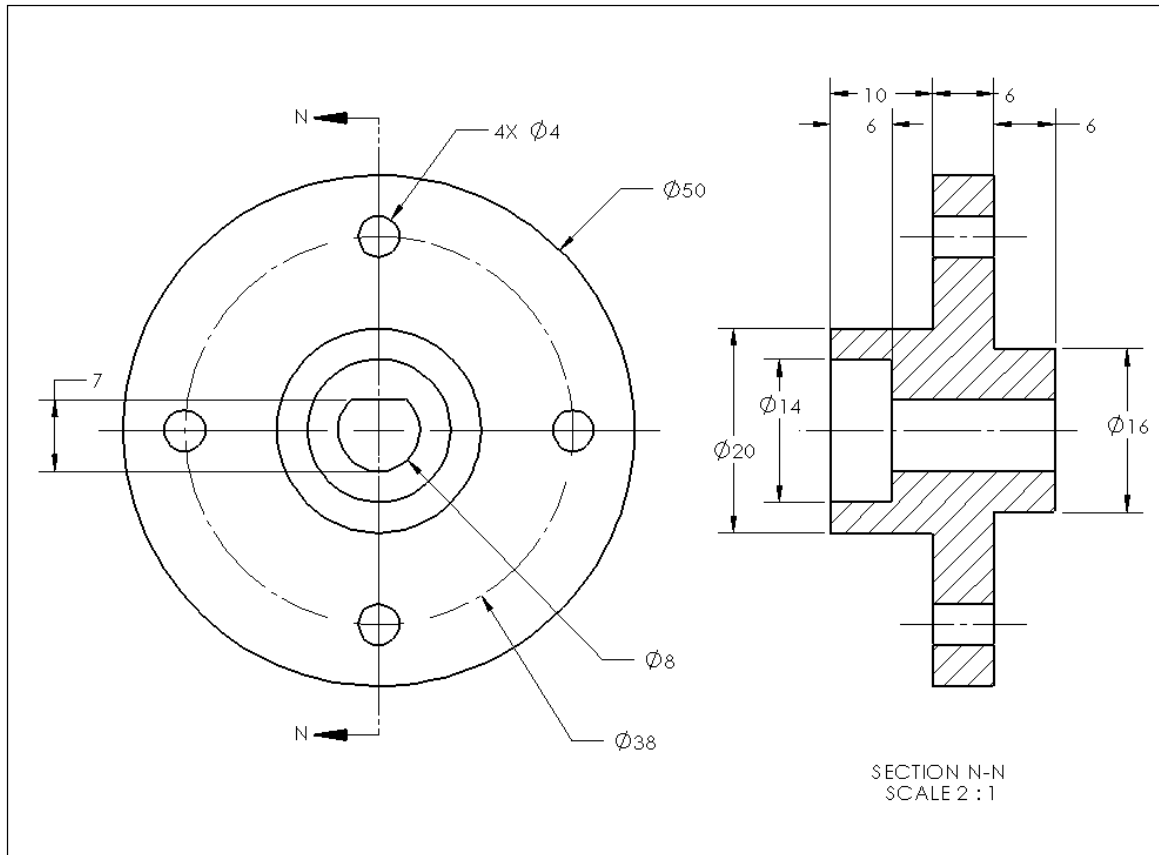
Figure 1-29 shows two additional section views to dimension the cross hole and Woodruff keyway. The Woodruff key is a standard key with a 28 mm diameter, 6 mm thickness, and 11 mm height. The manufacturer calls for the width of the keyway to be 6 mm, the radius of the keyway to be 14 mm, and the depth of the keyway to be 7.5 mm below the surface. The 7.5 mm depth leads to a distance of 32.5 mm between the keyway bottom and the opposite face of the shaft. Search the internet for “dimensioning of Woodruff keyways” for some examples.

The size of the spring pin hole is indicated to be 5.1 mm to match the manufacturer’s recommendation for a 5 mm spring pin. The 20 mm functional location is specified on the section view. Finally, the compact chamfer notation should be added to describe the chamfer detail at the end of the shaft. The internal geometry of all the features is now defined and each feature is adequately located.



**Figure 1-29. Dimensioning of the spring pin hole and the Woodruff keyway**

The part shown in Figure 1-30 is the drawing for a flange shape representing parts that attach to a shaft and usually have hubs, keyways, bearing holes, centering bosses, and fastener hole patterns. Flange-type parts are best shown using front and section views. Note that the inner D-shaped cylindrical hole is dimensioned as a diameter because this hole is intended to fit a shaft. Other cylindrical dimensions are shown in the section view where it is clear whether they are bosses or holes.



**Figure 1-30. A typical flange-type component that often fits shafts and bearings**

Missing dimensions and vague geometry information are serious errors and must be avoided. Always check for missing dimensions at the end by pretending to be a virtual machinist attempting to build all of the part's features using a virtual milling machine and a virtual lathe. Going through this virtual building procedure catches missing or vague information and also alerts you about features that may be difficult to make economically. Subsequently the design may be altered for easier manufacturing.

Figure 1-31 shows the dimensioning method used to describe the geometry of the crank part. While dimensioning to the points of tangency between lines and curves is not preferred, in this case the 70 mm flat side distances are dimensioned to define the theoretical shape of the part.

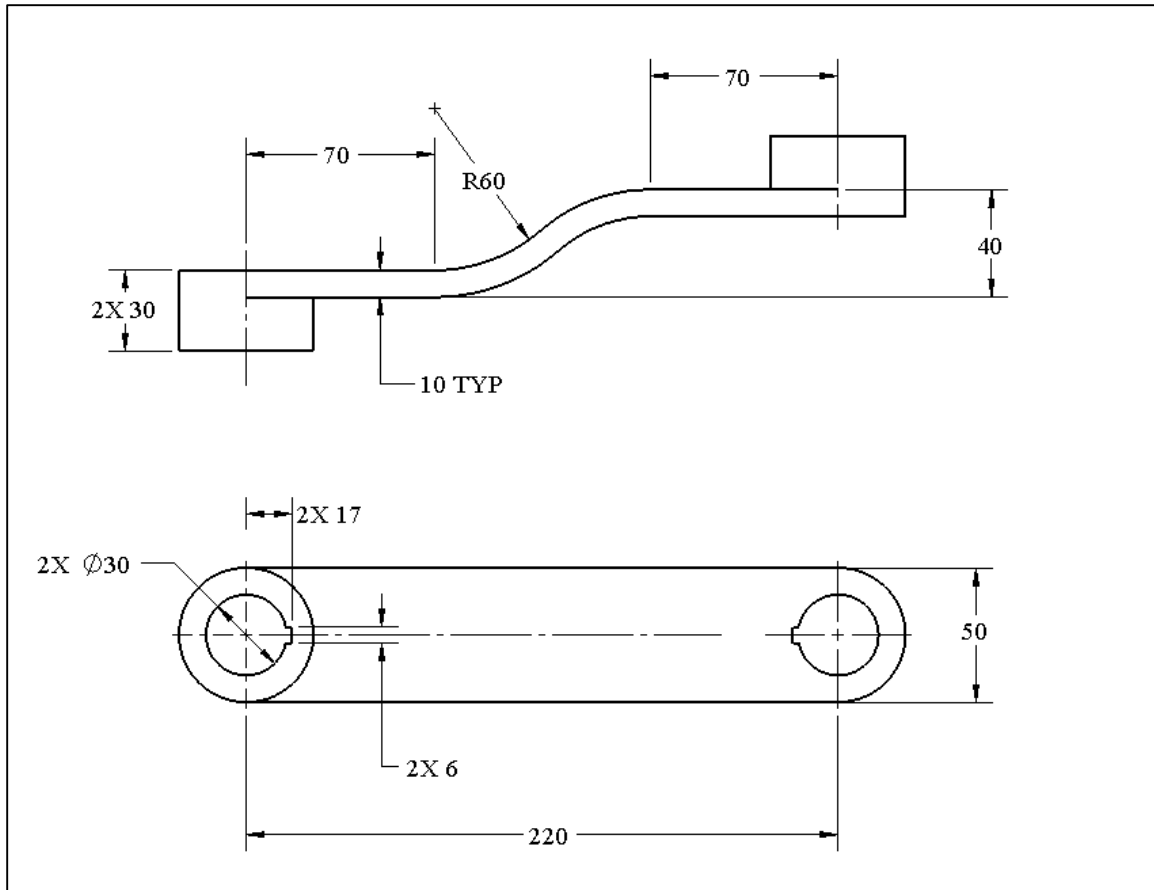


Figure 1-31. Dimensioning of a part with bent features

## 1.7. Figures of accuracy for dimensions and tolerances

When a theoretical dimension need not be controlled with precision, it is a good practice and often most economical to round the dimension value up or down as much as possible without being objectionable for other reasons. For example, if the theoretical model for a holding bracket happens to have a precise dimension without a particular reason, consider dropping the unnecessary figures of precision. For example, if a bracket dimension, based on some strength calculations, comes out to be 247.652 mm, consider using 247, 250, or 240 mm instead. If the dimension is the result of some analysis other than those associated with precision fits, apply the 1% dimension rule. Simply calculate 1% of the dimension (in this case about 2.47 mm) and round the number up or down to within the 1% value. In this case, a rounded value can be any number between 245 and 250 mm.

If the theoretical dimension is a result of precision fit calculations, apply the 1% rule to the tolerance value to get a more rounded value for the theoretical dimension. For example, suppose the tolerance applied to a 247.652 mm size dimension is to be  $\pm 0.8$  mm. One percent of the tolerance is  $\pm 0.008$  mm. Add and subtract this 1% of the tolerance value to the theoretical dimension to obtain a high and a low acceptable value.

In this case the high value is 247.660 and the low value is 247.644 mm. Use the roundest number between these limits. In this case 247.65 mm is a good choice. The resulting specification becomes  $247.65 \pm 0.8$  mm.

### Exercise Problems

1. Use a CAD system to model and fully dimension the housing endcap shown in Figure 1-32. The outer diameter of the part is 52 mm. The other dimensions are up to you.

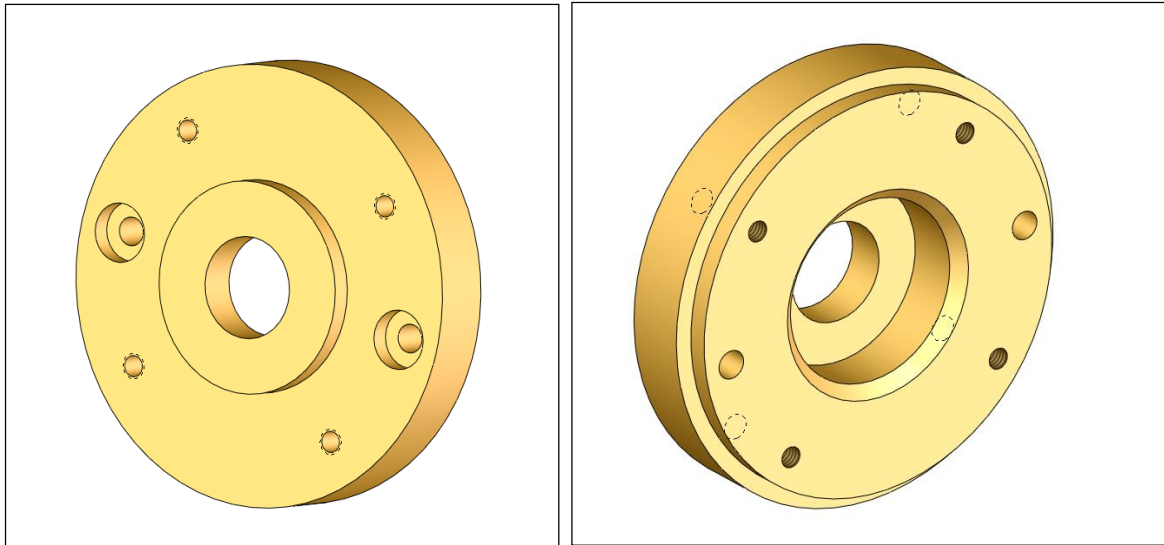


Figure 1-32. The front and back views of the housing endcap

2. Use a CAD system to model and fully dimension the turning support shown in Figure 1-33. The overall width of the part is 80 mm. The other dimensions are up to you.

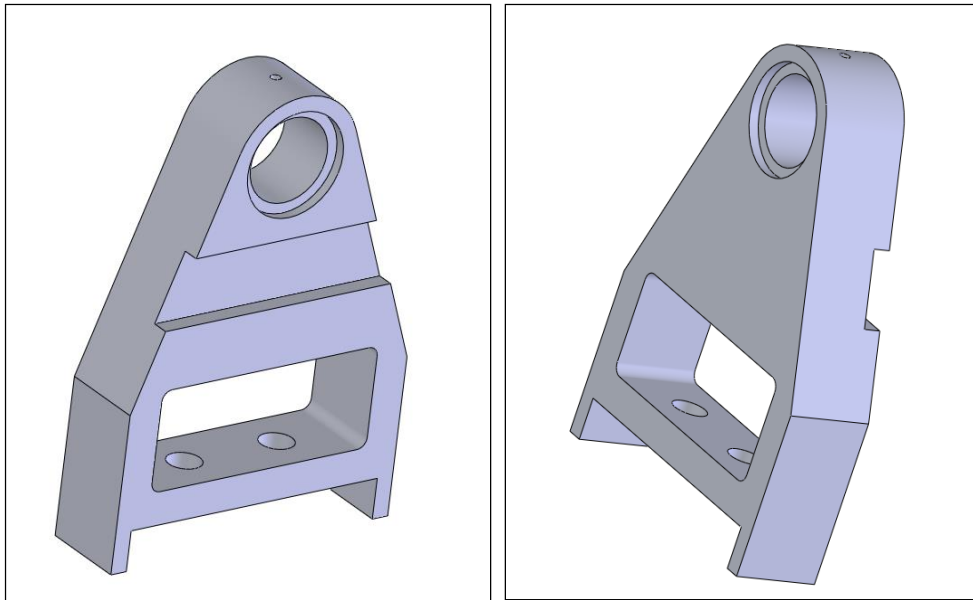
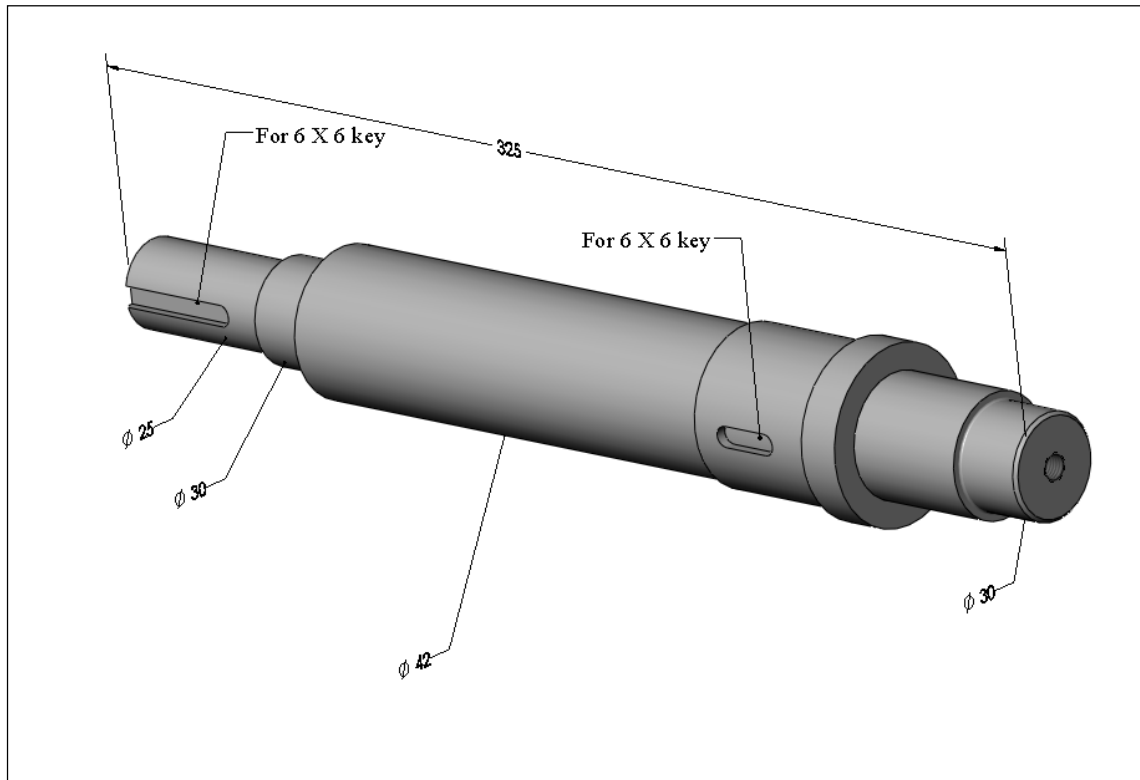


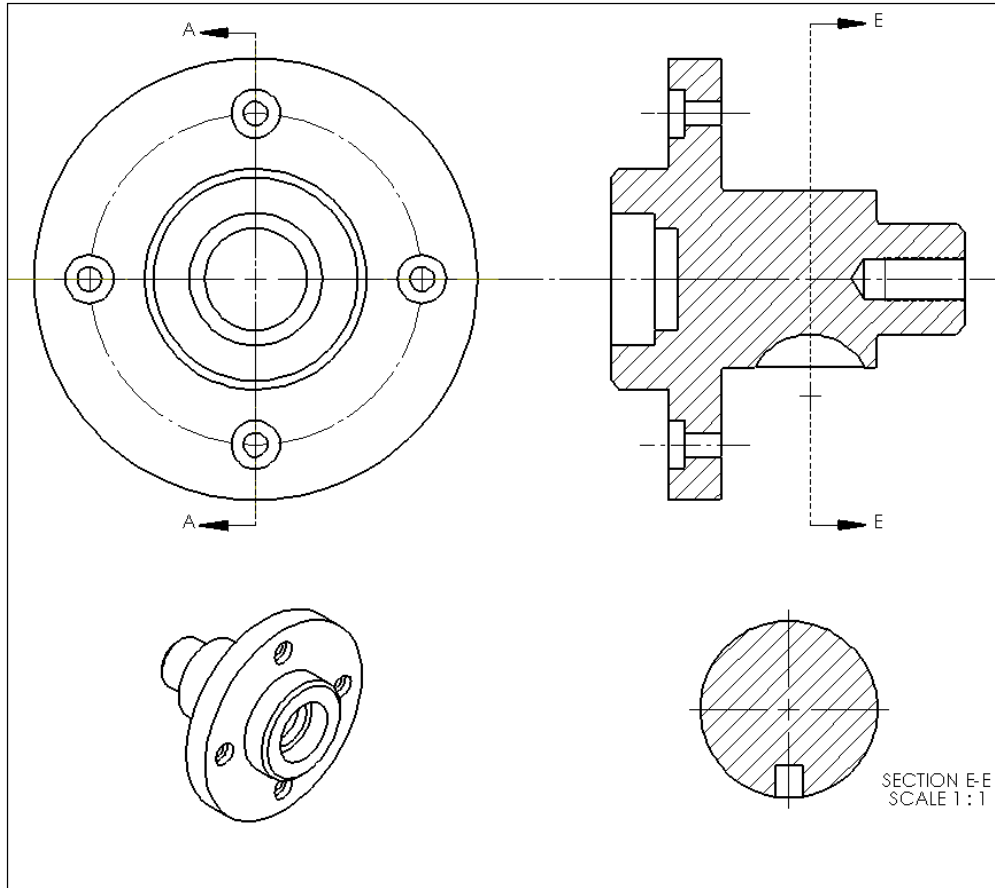
Figure 1-33. The turning support

- Use a CAD system to model and fully dimension the part shown in Figure 1-34. The shaft is 325 mm long. The 30 mm diameter cylinders fit to ball bearings. The keyway in the middle supports a gear and the keyway at the end of the shaft supports a belt pulley. There is a M8x1 threaded hole on one end of the shaft as shown in the figure. The drill hole for the threaded hole is 19 mm deep and the thread is 16 mm deep. The rest of the dimensions are up to you.



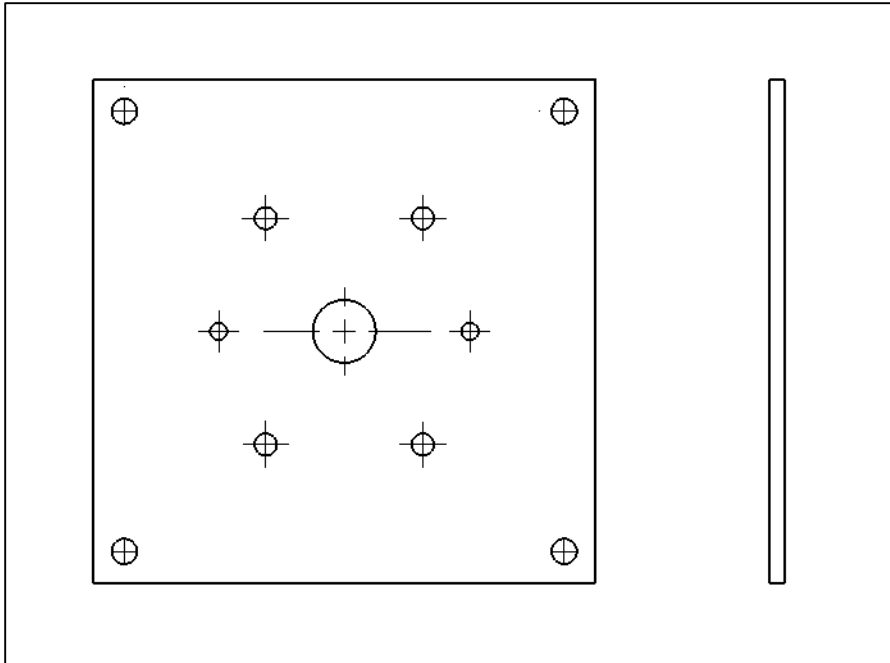
**Figure 1-34.** A power transmission shaft

- Use a CAD system to model and fully dimension the part shown in Figure 1-35. The plate length is 200 mm and the counterbored holes are for 6 mm screws.



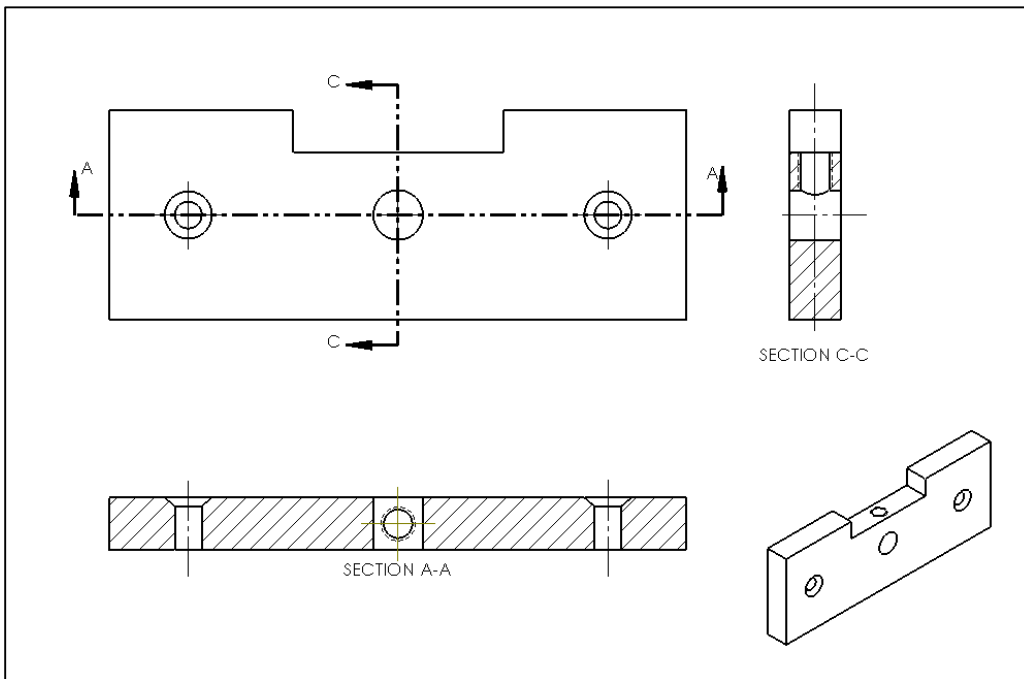
**Figure 1-35. A flange with counterbored holes**

5. Use a CAD system to model and fully dimension the plate part shown in Figure 1-36. The plate is purchased as 4 inch by 4 inch with a thickness of 0.125 inch. Display these dimensions as reference and as dual dimensions. The corner holes are 5 mm. The pattern of four holes in the middle are 4 mm threaded holes. The pattern of two holes are 3 mm threaded holes. The center feature is a through hole.



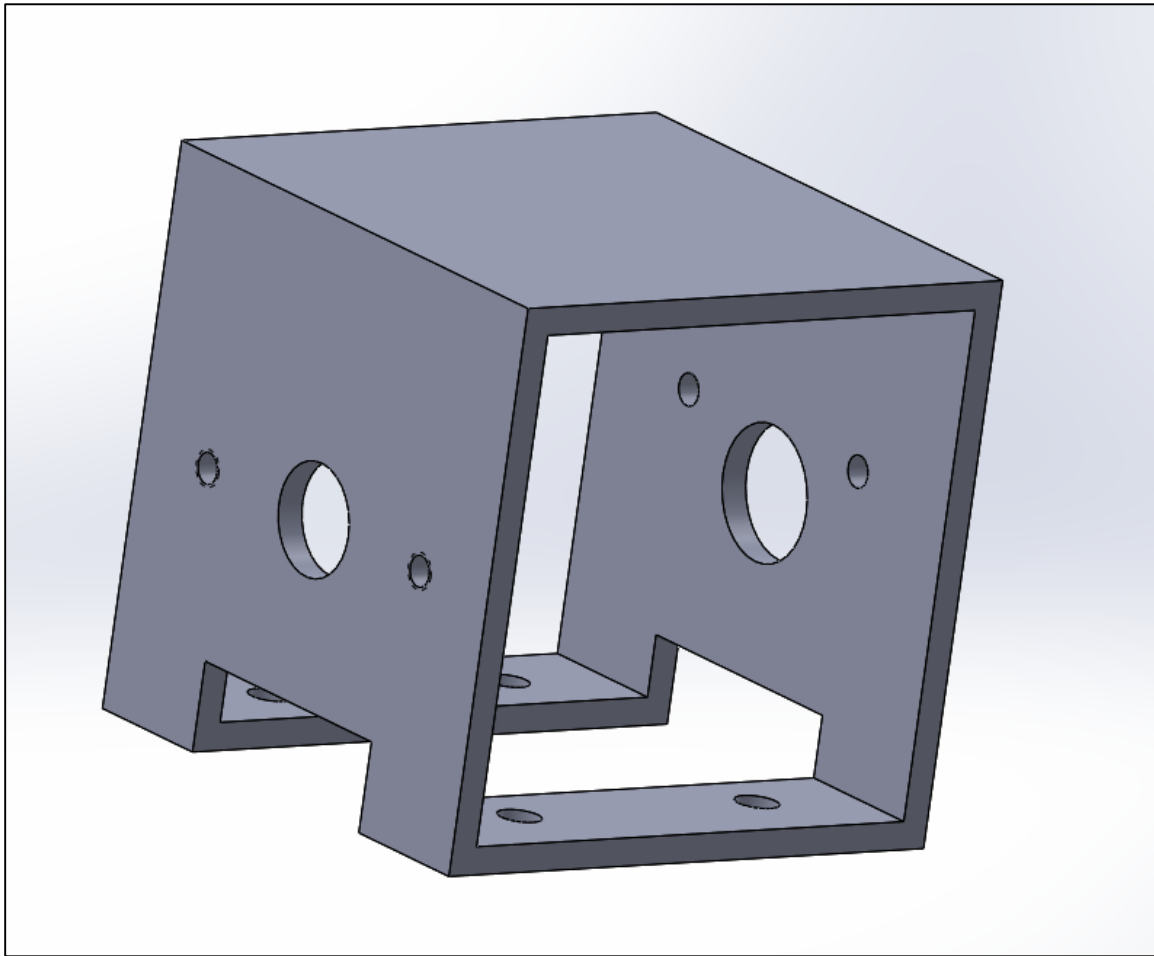
**Figure 1-36. A plate with threaded and through holes**

6. Use a CAD system to model and fully dimension the plate part shown in Figure 1-37. The plate is 1 inch wide and 0.25 inch thick. Display these dimensions as reference and as dual dimensions. The pattern of two countersunk holes are for 3 mm screws. The set screw hole is also for a 3 mm screw.



**Figure 1-37. A plate with threaded holes and countersunk holes**

- Use a CAD system to model and fully dimension the square tubing shown in Figure 1-38. The square tubing is 2.5 inch by 2.5 inch in outer dimensions. The thickness is 0.25 inches. Show these dimensions as reference in dual dimension format. The center holes are aligned but have different sizes. There is a pattern of two threaded holes and two clearance holes on each side face of the tubing. There is a pattern of four clearance holes on the bottom surface. Create appropriate drawings for this part and complete its dimensioning.



**Figure 1-38. A square tubing with patterns of holes and a slot**

- Find a real machine part and measure its features. Then, use your CAD system to model and fully dimension the part. Include an actual picture of the part.
- Search the internet for recommended dimensioning methods of other common features. Use your CAD system to model a simple part with a variety of common features and fully dimension the part.

# Chapter -2

## A Design Engineer's Overview of Tolerance Statements - Part-I

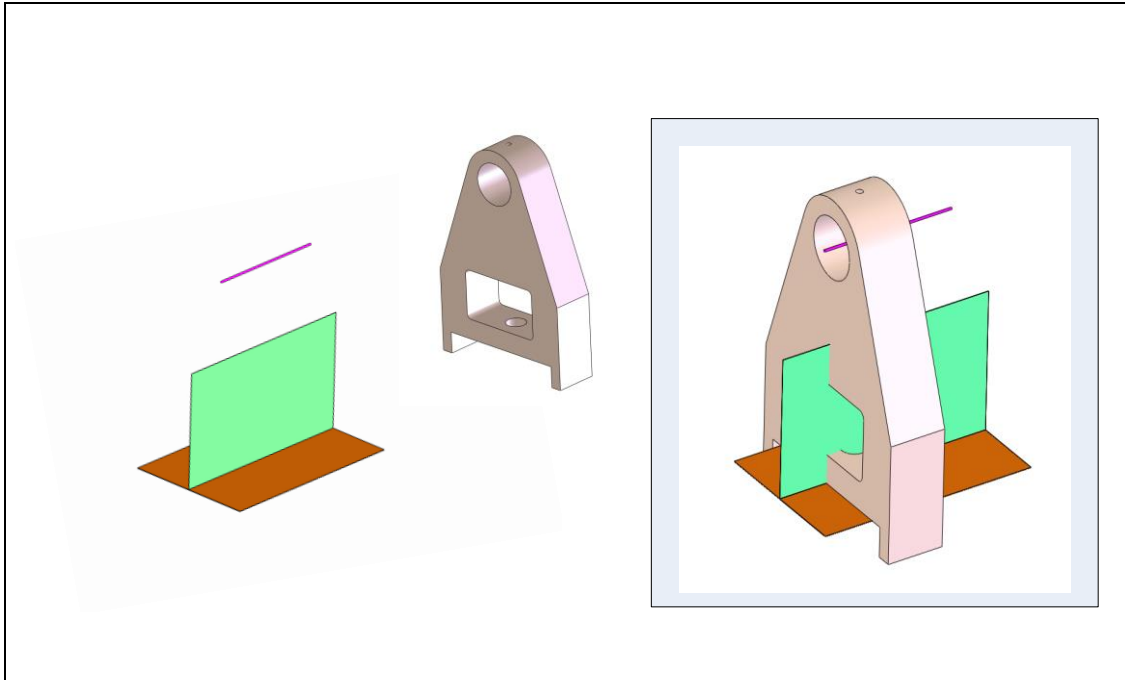
### 2.1. Overview

The next two chapters present a designer-oriented overview of the GDT standard tolerance specification statements. The objective here is to provide a basic understanding of how a designer can call for geometric accuracy and how geometric tolerancing statements are interpreted. Geometric tolerances along with dimensional tolerances ( $\pm$  or dimension limits) comprise the designer's toolbox for controlling the geometric aspects of part features needed to ensure fit and function. This chapter presents the tolerances of form and orientation. The following chapter continues with tolerances of location and profile.

### 2.2. Interpretation of geometric tolerances

The interpretation of most geometric tolerancing statements is straightforward and intuitive. Each tolerance statement can be interpreted by creating a theoretical gage which serves as an acceptance template. The gage dictates how close the features should be to their perfect geometry in order to be acceptable. The gage be conceptually held against the actual part to check the part's acceptability. Not only is the gage geometry important but the manner of holding the gage against the actual part can be important as well. Tolerance control statements disclose the information necessary to build the theoretical gages and define the method of gaging. Theoretical gages reflect the true meaning of tolerance statements but they may not be practical to build or use. Inspection personnel are trained to use alternative procedures and come up with decisions that conform to those obtained by theoretical gaging.

As an example, Figure 2-1 shows a theoretical gage and the theoretical gaging procedure.



**Figure 2-1. Theoretical gage (left) and theoretical gaging (right)**

The left side of the figure shows a theoretical gage made up of two planes and a small diameter cylinder that appears like a line. The right side of the figure shows the gaging process in which the gage is aligned against the actual part. This chapter and the next chapter present the details of how to define theoretical gages for each tolerance statement and how to align them against actual parts.

Most theoretical gages are three-dimensional. They are created from planes and cylinders and other 3D features. There are also tolerance statements that control feature cross-sections. These tolerance statements lead to two-dimensional gages or planar templates that are constructed on a plane.

When tolerance statements are applied to part surfaces or cross-sectional curves, the tolerance verification is straightforward and simply requires checking the subject feature surfaces or cross-sectional curves against a tolerance zone. When tolerance specifications are applied to axes or center planes, the tolerance interpretation must prescribe how the subject feature is to be derived from the surface features. The method of identifying the derived features is a part of the gaging process.

Theoretical gages along with the gaging instructions capture the true meaning of the tolerancing specifications. In describing a tolerance statement, designers only need to explain the gage geometry and the gaging procedure. Theoretical gages are easy to define as their geometry closely mimics the tolerance specification. Geometric tolerances allow design engineers to control a feature's size, form, orientation, and location with respect to other features.

### 2.3. Dimensional tolerances

Dimensional tolerances refer to the direct dimension limits or  $\pm$  tolerance values and can be applied to any dimension that defines a part. When dimension limits are applied to features known as features-of-size (FOS), the meaning of the dimension limits is explained in the GDT standard in terms of acceptance gages. Regular FOS are cylindrical, spherical, or width features (slots and rails) that are toleranced with dimension limits. When dimension limits are used to control size or location of other features, their meaning is not defined in terms of gages - they are defined in terms of measured dimensions. This means the inspector has to make a measurement that corresponds to the toleranced dimension and compare that against the limits. Since manufactured features have deformations and distortions, it is impossible to assign a unique measured value to such dimensions without subjectivity. For that reason, the use of dimension limits on features other than FOS is discouraged. A simple design guideline is that if the feature does not fit into anything then it should not be dimensioned using  $\pm$  dimension limits even if the feature is a complete cylinder or slot.

In this section, the meaning of dimension limits is explained when they apply to regular features-of-size. Precision fits usually involve regular FOS as these features are easier to manufacture with high accuracy. Dimension limits applied to regular FOS apply to all feature cross-sections. The theoretical gage for a cylindrical feature is made up of two circles on a plane – one at each limit of size as shown in Figure 2-2.

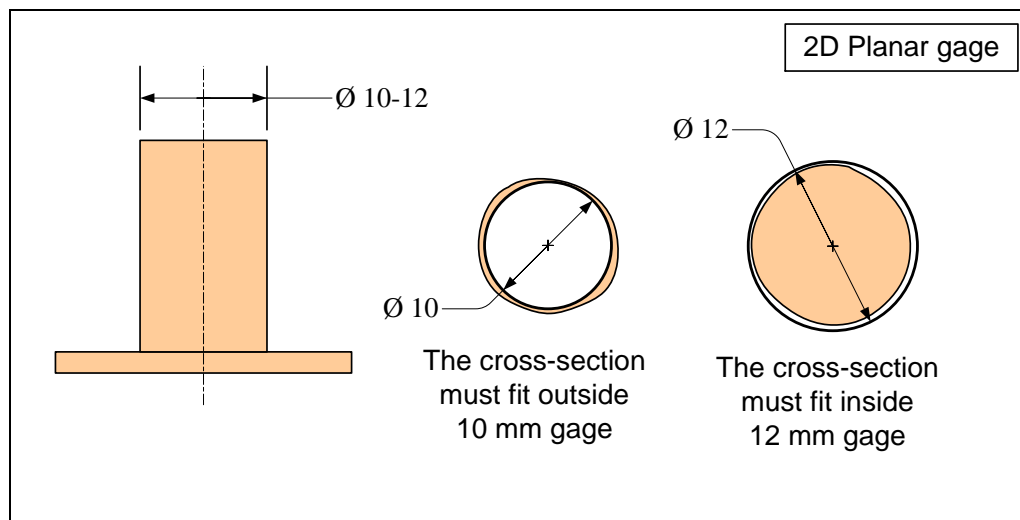


Figure 2-2. Theoretical gages for checking the size limits of a pin

The gaging procedure requires maneuvering the 2D gages to determine if the actual feature cross-sections can fit inside the larger circle and outside the smaller one. An inspector may use a caliper as an approximation of this theoretical gaging procedure. The caliper can be set to 10 mm to define the smaller gage and to 12 mm to define the larger gage. The 12-mm caliper must clear all the cross-sections (GO gage) while the 10-

mm gage should not clear any cross-section (NOGO gage). For width features, the gages are composed of pairs of parallel planes as shown in Figure 2-3.

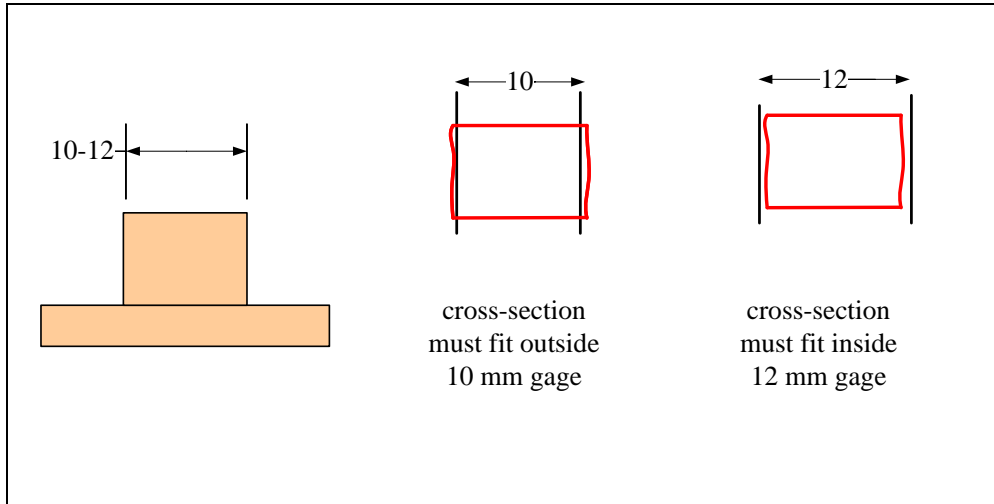
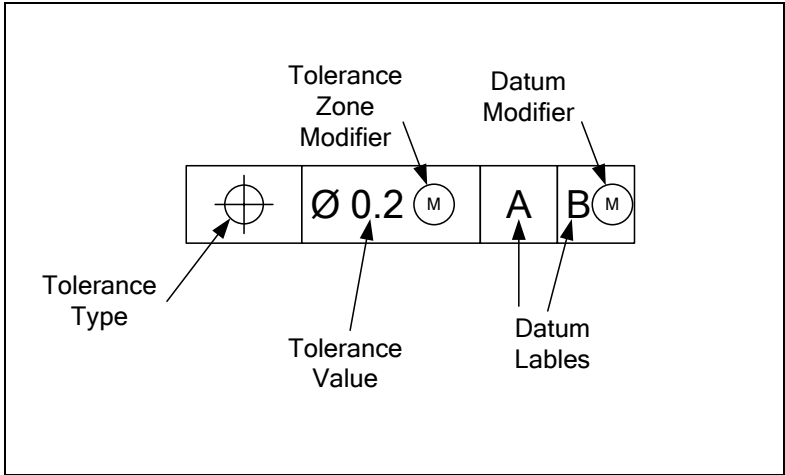


Figure 2-3. Size of a rail feature checked by two gages

In this case, the cross-sections are to be smaller than 12 mm and larger than 10 mm. A partial cylindrical surface, such as a shaft with a keyway, is also a regular FOS as long as the cross-section is defined enough such that a mating cylinder can fit in it without falling out. A cylindrical fillet, for example, is not a regular feature-of-size.

## 2.4. Geometric tolerances

Geometric tolerances are applied to features using a tolerance control box as shown in Figure 2-4. The feature that receives the specification is the *subject feature*. Note that in geometric tolerancing practice, the CAD model defines the exact, theoretical, or basic shape of a part and tolerance statements define the degree of deviation allowed from such a theoretical geometry. The deviations can be with regard to size, form, orientation, location, or any combination of these geometric aspects.



**Figure 2-4. Tolerance control box**

Table 2-1 shows the GDT standard tolerance types along with one example of their syntax.

	Sym	Specification	Example		
Form	—	Straightness	—	Ø 0.25	
		Flatness		0.25	
	○	Circularity	○	0.25	
		Cylindricity		0.25	
Orientation	∠	Angularity	∠	0.25	A
	⊥	Perpendicularity	⊥	Ø 0.25	Ⓜ A
	//	Parallelism	//	0.25	A
Location	⊕	Position	⊕	Ø 0.2	A B C
	◎	Concentricity	◎	0.25	A
	≡	Symmetry	≡	0.25	A
		Circular Runout		0.25	A
		Total Runout		0.25	A
Profile		Profile of a Line		Ø 0.2	A B
		Profile of a Surface		Ø 0.2	A B

**Table 2-1. Tolerance types and examples of their usage format**

The following sections will present the meaning of the tolerances of form and orientation.

## 2.5. Tolerances of form

Tolerances of form limit the geometric deviations of feature form relative to their perfect or theoretical geometric form. Form is a geometric characteristic independent of size. The best distinction between form and size can be observed in the shape of sport balls such as a basketball. A basketball can be functional over a considerable range of sizes, but if it is not round or circular enough, it would not bounce predictably and becomes useless. To be useful, a basketball requires much higher circularity precision than size precision. Table 2-2 shows the tolerances of form and the frequency of their use in fit-related applications by machine designers. A 5-star frequency rating means the usage is very high, and a 1-star rating means rare usage.





Symbol	Specification	Typical Features	Frequency of Use
	Flatness	Flat surfaces Center planes of slots or rails	*****
	Straightness	Axis of cylinders Straight edges Straight cross-section lines	***
	Circularity	Circular cross-sections	**
	Cylindricity	Cylindrical surfaces	*

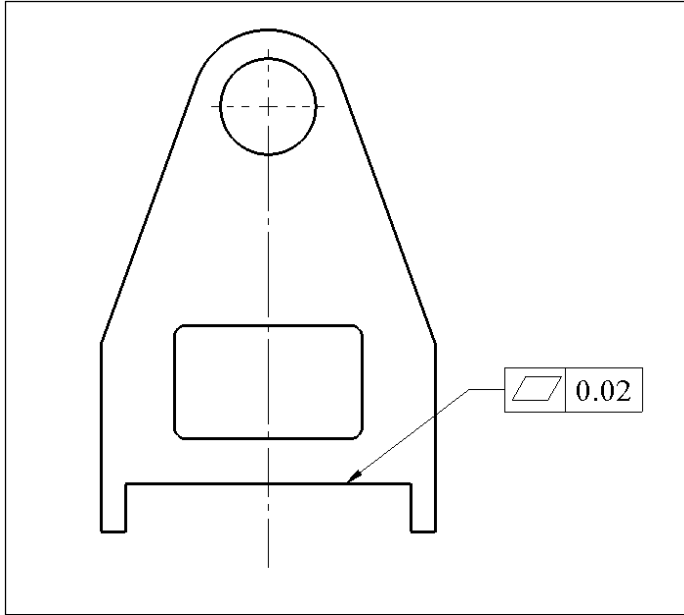
Table 2-2. Tolerances of form

Flatness and straightness are important fit-related specifications while circularity and cylindricity are needed for specific functional reasons such as sealing or lubrication-related applications.

## 2.6. Flatness

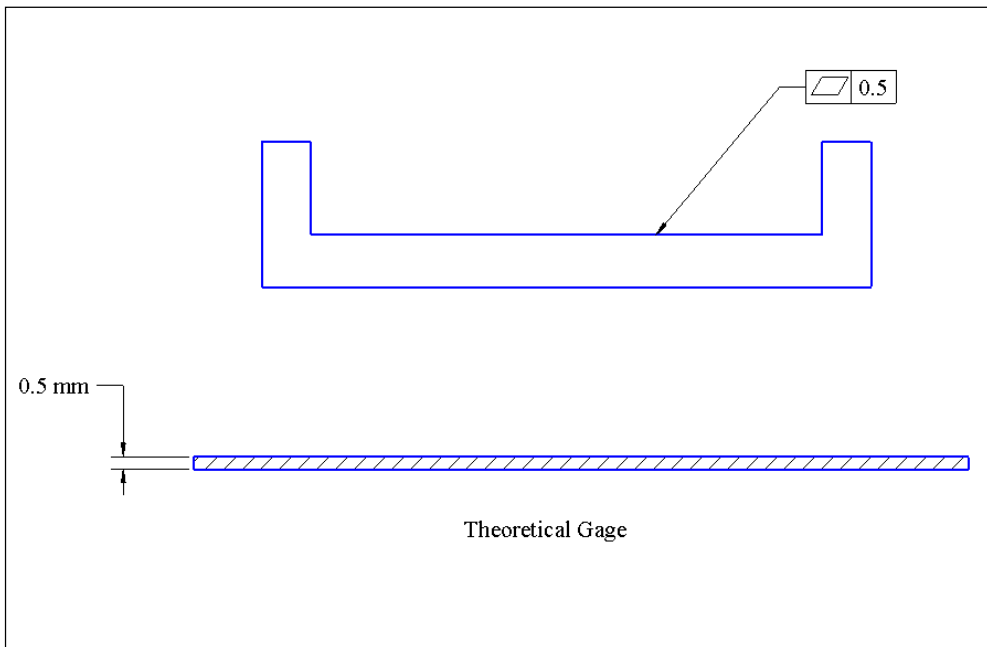


Flatness requires a planar surface, or the center plane of a width feature (a slot or rail), to be flat to within the specified tolerance value. An example of flatness specification is shown in Figure 2-5. In many manufacturing sites it is a more common terminology to use the phrase “call out” instead of “specification”. For example, the flatness tolerance is called out to be 0.02 mm.



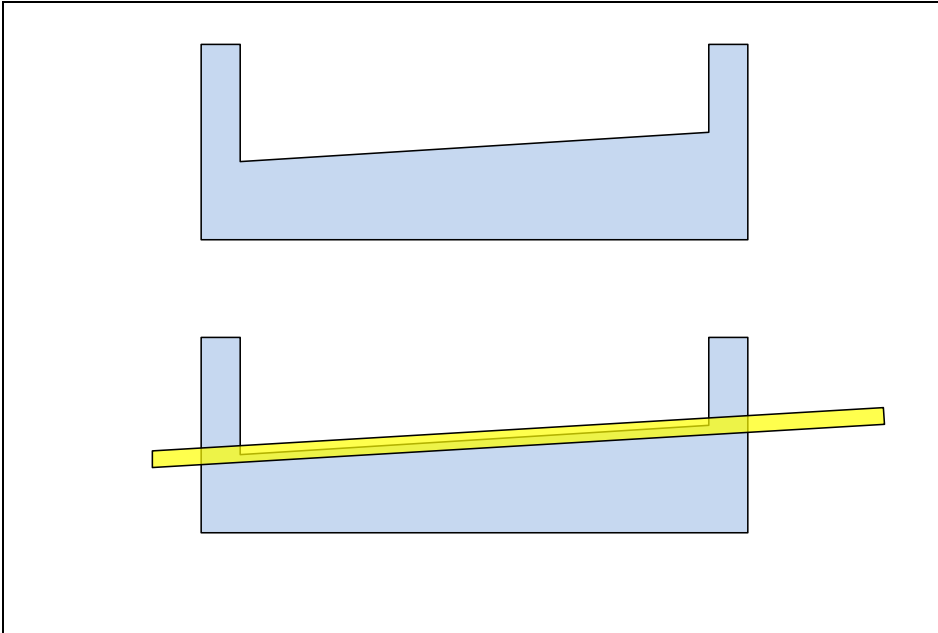
**Figure 2-5. Specification of flatness control**

The theoretical gage for flatness is a pair of parallel planes defining an acceptance zone or a tolerance zone. The flatness tolerance value defines the separation between the tolerance zone planes. The theoretical gaging procedure for flatness requires maneuvering the gage to determine if the entire surface of the feature can fit inside the tolerance zone of the gage. Figure 2-6 shows a flatness specification and its theoretical gage.



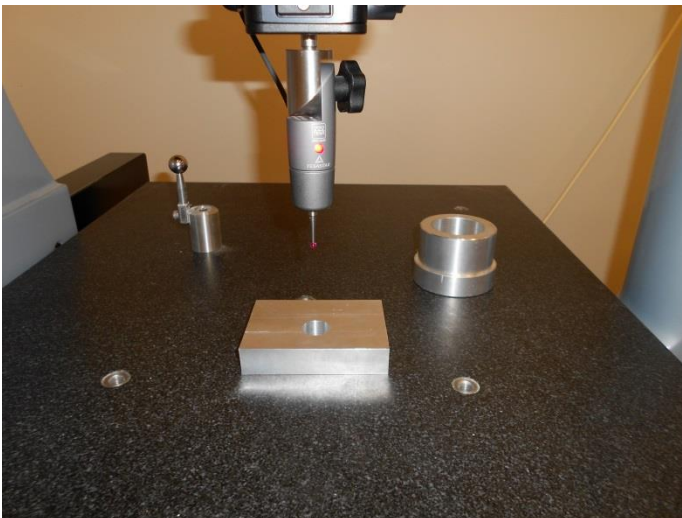
**Figure 2-6. Theoretical gage for flatness tolerance specification**

Note that flatness does not check parallelness and therefore a feature like the one shown in Figure 2-7 has acceptable flatness as it entirely fits within the gage.



**Figure 2-7.** A feature with acceptable flatness as the entire surface fits inside the gage

A common method for inspection of geometric tolerances is by using a coordinate measuring machine (CMM). A CMM can sample a surface at many points and use mathematical procedures (soft gaging) to simulate a theoretical gaging process. Using CMMs with soft gaging programs come closest to inspecting features according to the theoretical gages. Figure 2-8 shows the inspection probe of a coordinate measuring machine.



**Figure 2-8.** A coordinate measuring machine probe

The stylus of the machine touches the feature surface at many points and sends the coordinates to the computer. For example, for inspecting the flatness of the surface in Figure 2-6, the machine can collect ten or fifteen coordinate points on the feature surface. Soft gaging is a mathematical procedure that can determine whether the collection of the points can fit inside a pair of parallel planes with a separation of 0.5 mm.

## 2.7. Meaning of (M) symbol next to the tolerance value

Flatness control can also be applied to the center plane of width features. Figure 2-9 shows the meaning of the flatness control specification applied to a slot feature. The tolerance zone is as before, a pair of parallel planes with a separation defined by the tolerance value. The center plane points are identified by mid points of all intersecting lines extending between the two side faces of the slot. These intersecting lines are perpendicular to the sides of the widest parallel planes that fits inside the slot. The widest parallel planes are shown in red.

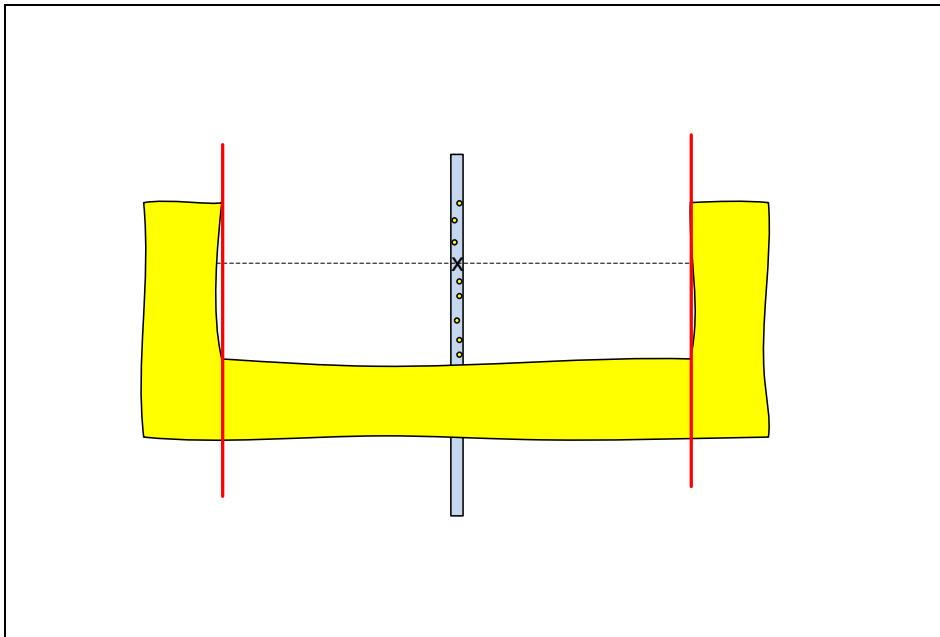
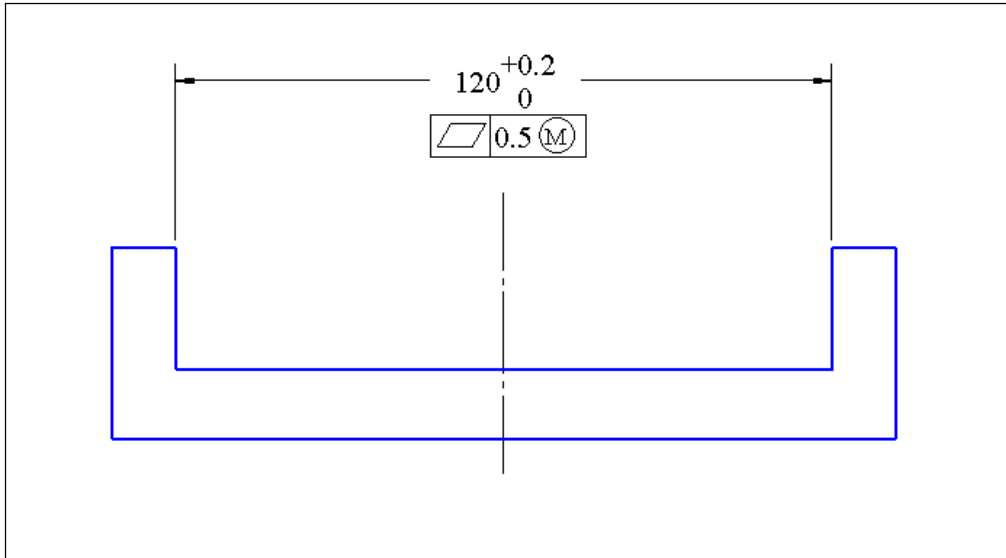


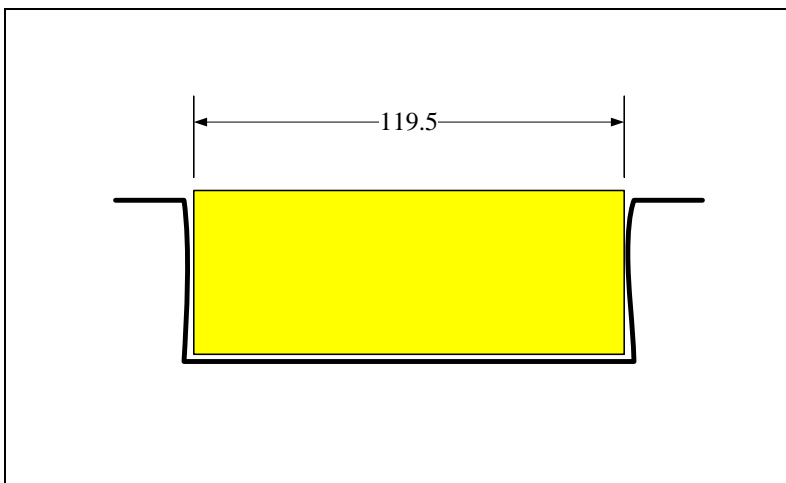
Figure 2-9. The meaning of flatness control applied to a slot feature center plane

For width features, the designer can also specify a (M) or (L) symbol following the tolerance value. The (M) symbol is the *maximum material condition* modifier and the (L) symbol is the *least material condition* modifier. An example is shown in Figure 2-10.



**Figure 2-10. Controlling the flatness of the center plane of a slot**

The  $\textcircled{M}$  symbol changes the subject feature from the center plane to the feature surfaces. The tolerance zone changes from the tiny zone of width 0.5 mm to an acceptance zone with a size of 119.5 mm. The size of the acceptance zone is obtained by subtracting the tolerance value of 0.5 mm from the smallest size of the feature which is 120 mm. Figure 2-11 shows the theoretical gage and an acceptable slot feature for the flatness specification of Figure 2-10.

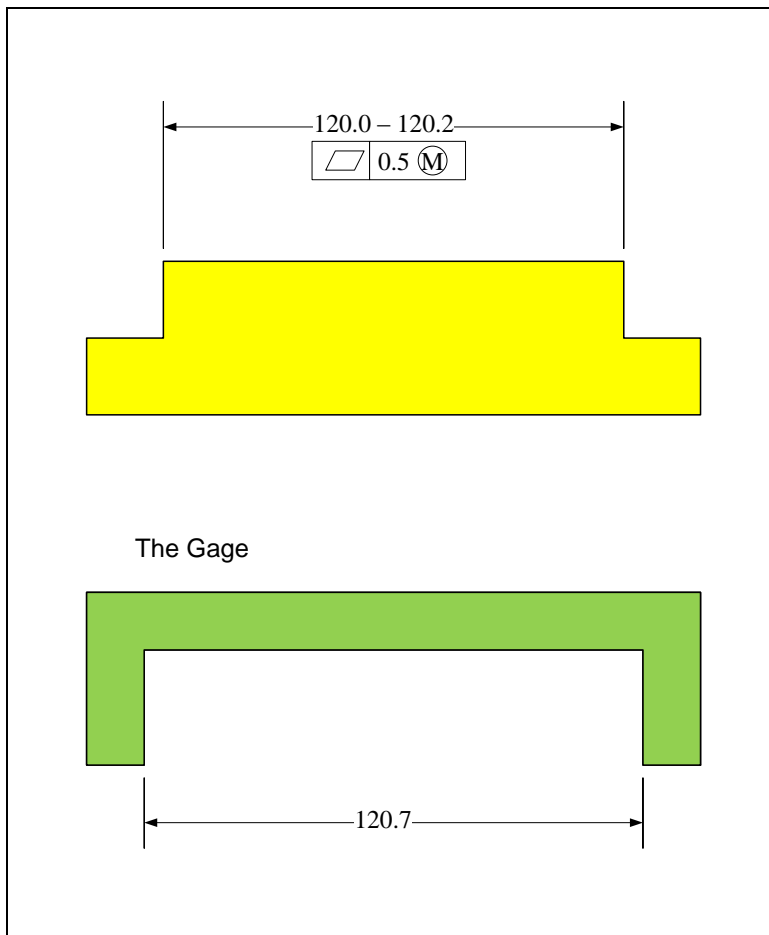


**Figure 2-11. The gage for the flatness of the center plane of a slot when  $\textcircled{M}$  modifier is used**

If the slot center plane is a little less flat, or the slot is made a little smaller in size, the feature would not be acceptable. It is clear that the  $\textcircled{M}$ -modified specification applied to a slot controls the combined size and form such that the slot's opening for fit would never be less than 119.5 mm. The  $\textcircled{L}$  modifier has a similarly defined meaning but since its application to fit is limited, we will just focus on the  $\textcircled{M}$  modifier in this chapter. The

meaning of the  $\textcircled{L}$  modifier will be presented in Chapter-3 after the position tolerance is explained. We will not see the use of an  $\textcircled{L}$  modifier until Chapter-10 on multipart fits.

Figure 2-12 shows an example of applying the  $\textcircled{M}$  modifier to a rail feature. When the  $\textcircled{M}$  modifier is applied to a rail feature, the gage has a slot shape. The size of the gage is calculated as the largest size of the rail (120.2 mm) plus the tolerance value (0.5 mm). The feature is accepted if it fits inside the slot.



**Figure 2-12.** The specification and gage for the flatness of the center plane of a rail when an  $\textcircled{M}$  modifier is used

The  $\textcircled{M}$  or  $\textcircled{L}$  symbols can be applied to other features-of-size especially cylindrical holes and bosses. The modifiers can also be applied to axis straightness tolerance, orientation control tolerances, and position tolerances as long as the features are features-of-size.

## 2.8. Straightness —

Straightness requires the axis of a cylinder (or a surface of revolution) to be straight. Figure 2-13 shows an example of the axis straightness control on the top figure. The theoretical gage for this straightness statement, shown in the middle figure, is a cylinder

with a diameter equal to the tolerance value. The theoretical gaging procedure requires maneuvering the gage (or the part) to determine if the entire feature *spine curve* can fit inside the tolerance zone. The bottom figure shows a feature with a bent spine.

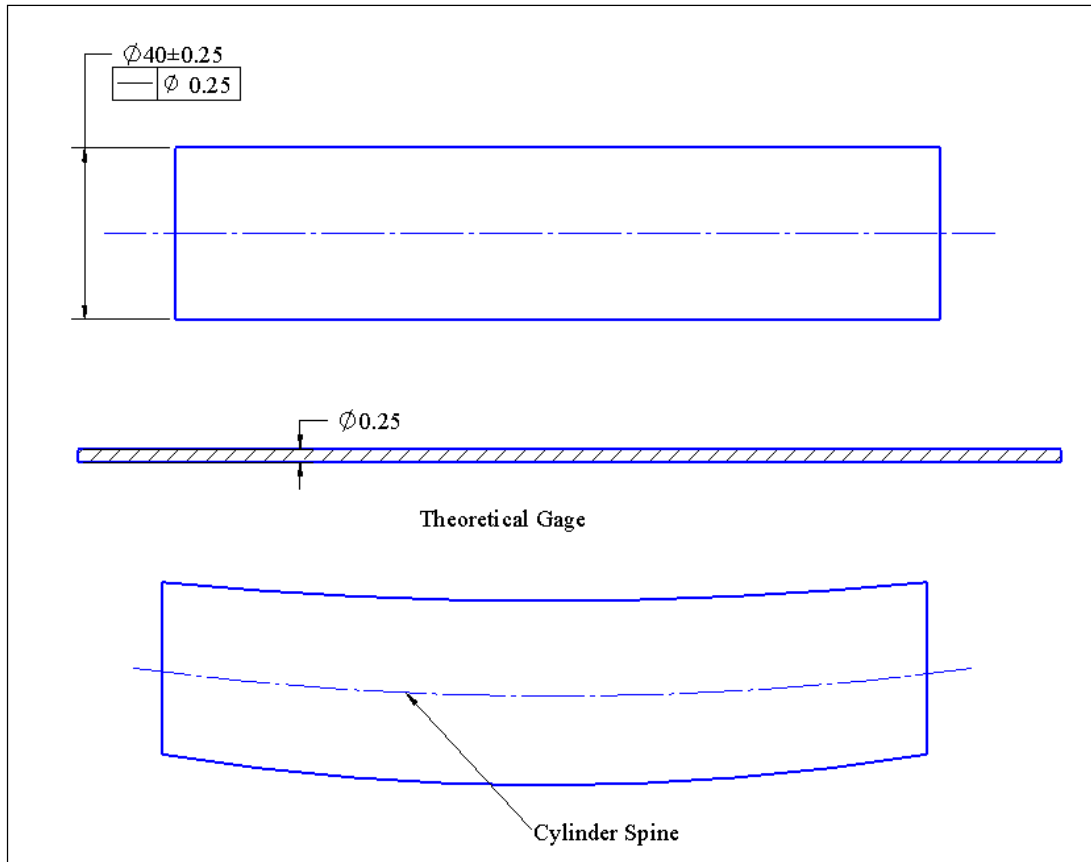


Figure 2-13. The theoretical gage for straightness and the spine of the actual feature

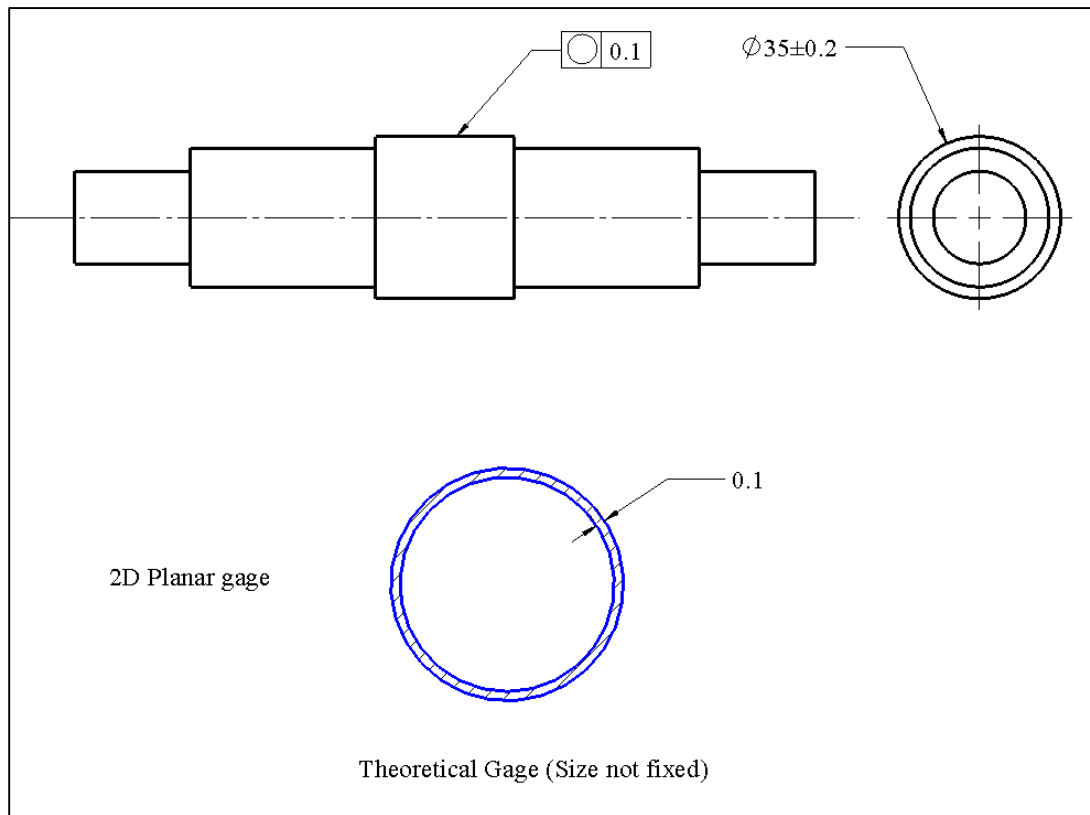
The spine curve of a surface of revolution is defined by the center points of all the cross-sectional curves of the feature. Straightness can also be applied to surface elements that are theoretically straight.

When an  $\textcircled{M}$  modifier is used following the 0.25 mm tolerance value, the gage becomes a tube of size 40.5 mm. The tube size is equal to the MMC size of the bar (40.25 mm) plus the stated tolerance of 0.25 mm at MMC. If the actual bar fits inside the gage tube, it is accepted. This means the combination of the bar size and bending leads to a bar that fits the gage and is acceptable.

## 2.9. Circularity ○

Circularity control applies to cylindrical features or features that have circular cross-sections. This statement requires that specified cross-sections or all cross-sections of

selected features to be circular in shape to within the stated tolerance value. Figure 2-14 shows an example.



**Figure 2-14. An example of circularity control statement**

The theoretical gage for circularity is a 2D (planar) annular zone between two concentric circles. The radial thickness of the annular zone is equal to the specified tolerance value. The size (diameter) of the gage is flexible. The circles can expand or shrink together as long as the radial thickness of the tolerance zone is unchanged. The gaging procedure requires cutting the feature with cutting planes to determine the cross-section curves and then maneuvering the gage to determine if every cross-section curve can fit inside a tolerance zone of a suitable size. The center mark for the gage circles is intentionally not shown to emphasize that the center of the gage need not align with any particular point during gaging. This means the gage only checks the circular form and not its location with respect to any other feature.

Note that the size tolerance of  $\pm 0.2$  mm automatically enforces a circularity of 0.2 mm. The separate circularity specification is just for finer form control. Reducing the size tolerance to  $\pm 0.1$  mm to achieve form control is wasteful as obtaining size precision is more difficult and costly than obtaining form precision.

## 2.10. Cylindricity

Cylindricity statement only applies to cylindrical features. This statement requires cylindrical surfaces to be cylinder-like in shape to within the specified tolerance value. The meaning of cylindricity is similar to circularity except that cylindricity is a three-dimensional tolerance that controls the form of the entire cylinder while circularity is a two-dimensional tolerance that controls the form of circular cross-sections.

The theoretical gage for cylindricity is the zone between two coaxial cylinders. The radial thickness of the tolerance zone is equal to the specified tolerance value and is fixed. The diameter of the coaxial cylinders is flexible. The cylinders can expand or shrink together as long as the radial thickness of the tolerance zone is unchanged. The gaging procedure requires maneuvering the gage to determine if the entire cylindrical feature can fit inside a gage with a suitable size.

Figure 2-15 shows a cylindricity specification and a theoretical gage with a tolerance zone.

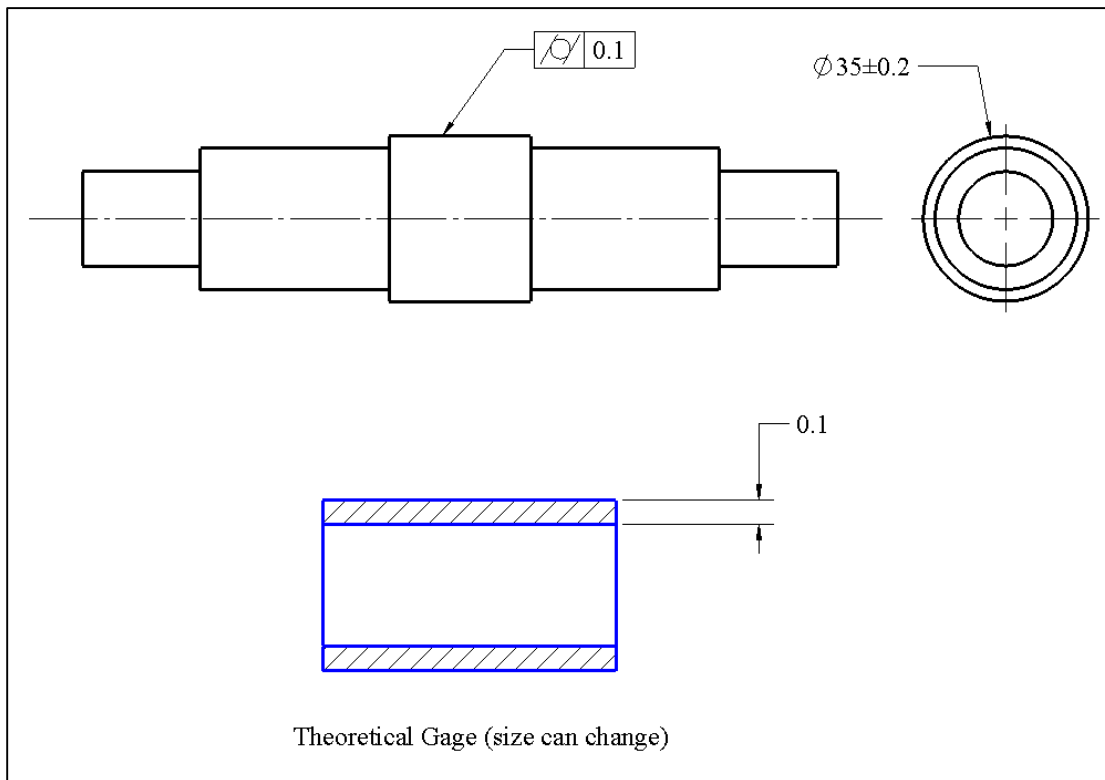


Figure 2-15. An example of cylindricity control statement and its gage

The axis of the tolerance zone is intentionally not shown to emphasize that the gage only checks the form of the feature. Note that if the feature is made having a conical, barrel shape, or hour-glass shape, it would have circular cross-sections and would pass a

circularity specification but not the cylindricity specification. Form tolerances only check the form of single features not their relationship to other features. For example, neither cylindricity nor circularity can assure that a subject feature is coaxial with respect to the axis of another feature.

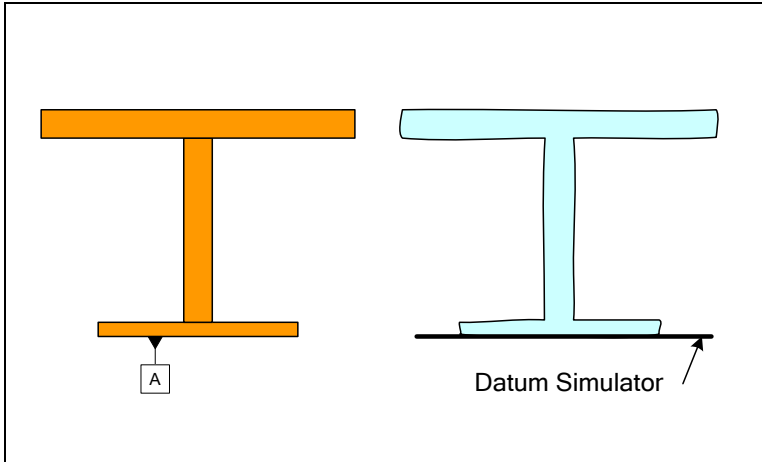
## 2.11. Tolerances of orientation

Tolerances of orientation are used to control the orientation of individual features such as planar surfaces or axes of cylinders relative to other reference features. The reference features, often planar surfaces or axes of cylindrical features, are called *datum features*. The following is the list of orientation-control tolerances.

Symbol	Specification	Typical Features	Frequency of Use
//	Parallelism	Planar, Axis	***
⊥	Perpendicularity	Planar, Axis	*****
∠	Angularity	Planar, Axis	**

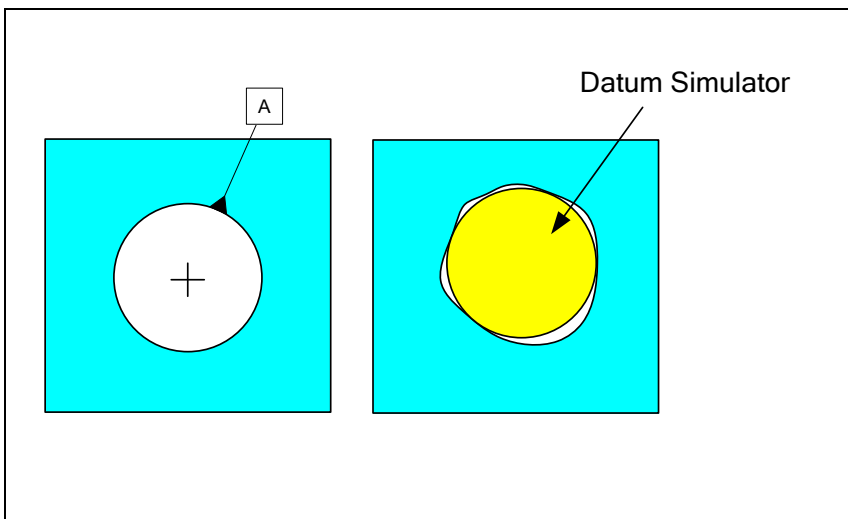
To explain the meaning of orientation tolerances, it is necessary to add constraint geometry or *datum feature simulators* to the theoretical gages discussed so far. The datum feature simulators (abbreviated to datum simulators) are identified by the labeling of datum features in the tolerance statement. While labels can be any alphanumeric symbol the preferred practice is to use the alphabet symbols in sequence starting with the letter A. Good choice of labels that meets the expectation of engineers and production personnel improves the readability of the tolerancing scheme and reduces interpretation errors.

A datum can be any geometry that can limit a part's translation or rotation. They mimic the way the part is placed into an assembly. For example, the datum simulator for a planar datum is a plane that constrains the translation and rotation of a part as shown in Figure 2-16. You can think of datum simulators as perfect physical surfaces that support a part just like mating part surfaces do when the part is placed into the assembly. Every datum label identified in a part drawing or model and referenced in a tolerance statement defines a datum simulator. Each datum simulator immobilizes some of the part's mobility with respect to the gage.



**Figure 2-16. An example of a datum label and a datum simulator**

The datum simulator of a hole datum is an expanding cylinder that fits inside the datum feature as shown in Figure 2-17.



**Figure 2-17. An example of datum simulator for a hole datum feature – the simulator is a pin**

For most machine parts datum simulators consist of planes, expanding (contracting) cylinders, or expanding (contracting) width features that grip the part. If necessary, a planar datum simulator can be specified to translate to fully engage and constrain a part. Other datum simulators can be specified to be points, lines, or small areas that can support or hold a part. These datum simulators, called *datum targets*, are often used when part surfaces are uneven such as with cast parts. The primary application of the datum targets will be presented in Chapter-4 on default tolerances.

## 2.12. Parallelism

Parallelism requires a surface or axis to be parallel to a datum surface or axis to within a specified tolerance value. Figure 2-18 shows a table for which the top surface is specified to be parallel to the bottom surface with a tolerance value of 5 mm. The reference surface used for orientation control is identified as a datum feature, in this case datum-A.

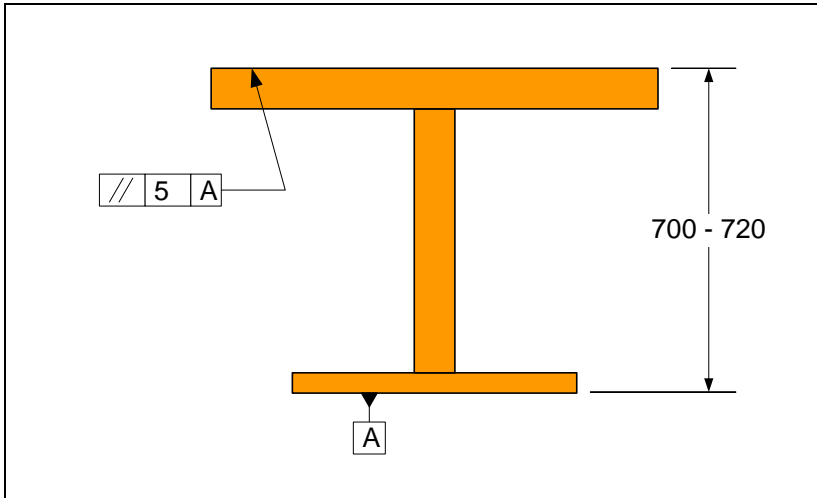


Figure 2-18. An example of parallelism control statement

The theoretical gage for this parallelism specification is composed of a tolerance zone geometry for the subject feature and a datum simulator for the constraint geometry. The tolerance zone geometry is parallel to the datum simulator plane but otherwise floating parallel to the datum simulator. Figure 2-19 shows the gage for the specification shown in Figure 2-18.

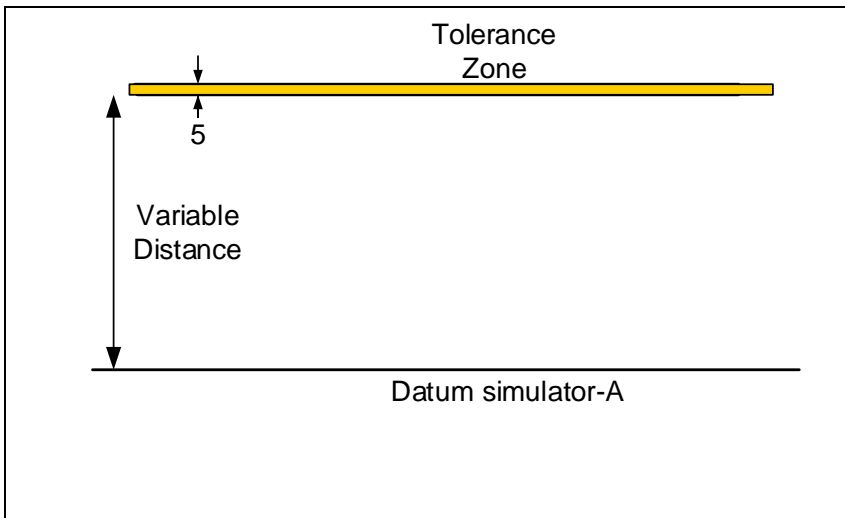
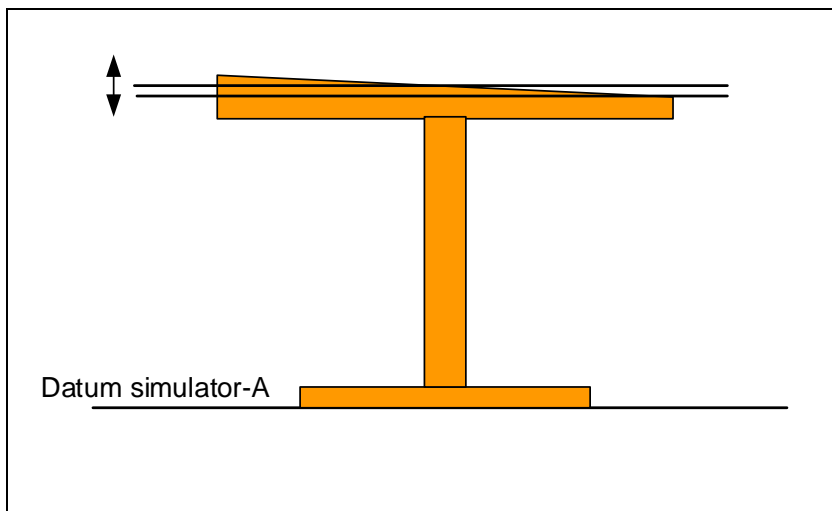


Figure 2-19. Theoretical gage for parallelism control

The theoretical gaging procedure for this parallelism specification requires two steps. The first step is for the part's datum-A feature to be firmly pressed against the datum simulator (Plane-A in the figure). Aligning the part to gage's datum simulators is called *staging*. Staging is the procedure that constrains the part with respect to the gage before the subject feature is checked against the tolerance zone geometry. The second step is to slide the tolerance zone parallel to the datum simulator to determine if the entire subject feature can be made to fit inside the tolerance zone. The gaging procedure is shown in Figure 2-20. In this case, the table-top is not sufficiently parallel to the bottom support because regardless of how the tolerance zone is moved, the entire feature cannot fit inside the zone.



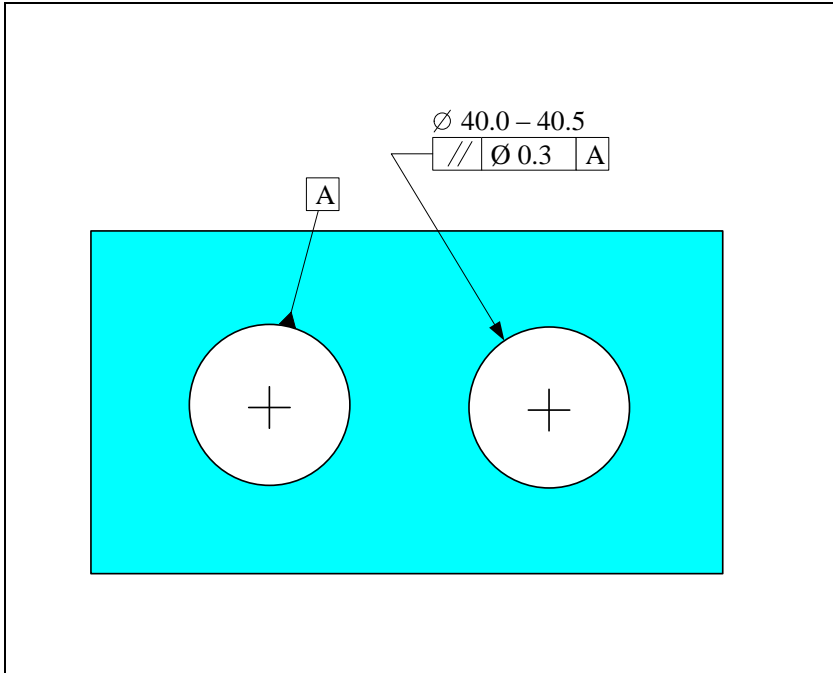
**Figure 2-20. Theoretical gaging procedure for parallelism statement**

Note that the size tolerance of 20 mm by itself controls the parallelism only to within 20 mm. If the size specification is changed to 700 – 705 mm, the desired level of parallelism is achieved. However, controlling parallelism or other orientation precision needs through size control is wasteful as the needed size control is more difficult and costly to achieve than orientation control.

Tolerances of orientation or location frequently involve cylindrical datum features or cylindrical subject features. The following section explains how the axes of cylindrical features are established.

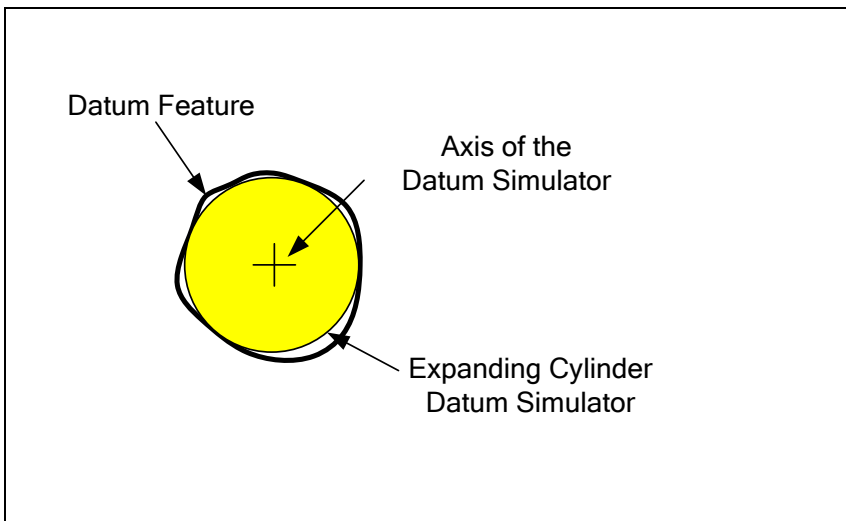
### **2.13. Identifying the axis of an imperfect cylinder**

Consider a parallelism statement that requires the axis of a cylindrical subject feature to be parallel to the axis of another cylinder chosen as a datum feature. An example is shown in Figure 2-21.



**Figure 2-21. A cylindrical feature to be parallel to another cylindrical feature**

When the datum feature is a cylindrical hole, the simulated datum is an expanding pin. During gaging, this pin fits inside the datum hole and expands until it fits fully inside the hole as shown in Figure 2-22.

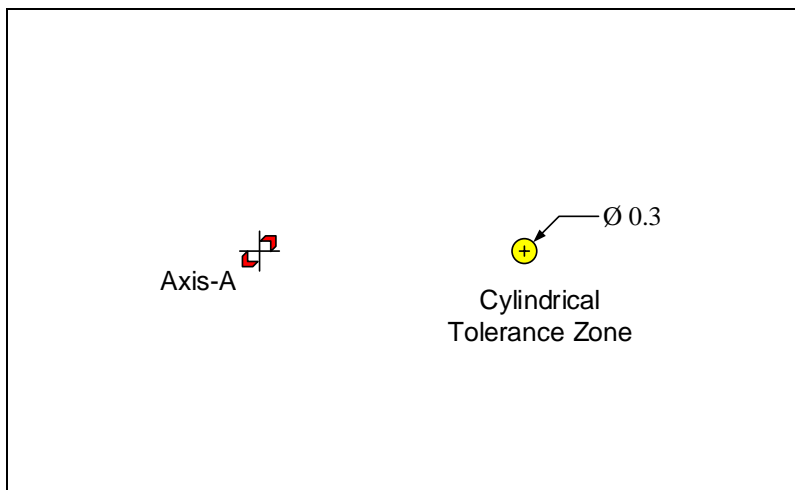


**Figure 2-22. Identifying the axis of a cylindrical feature**

There is a special name for the largest cylinder that tightly fits inside a hole – it is called an *unconstrained actual mating envelope* (unconstrained AME). The term unconstrained refers to the fact that the expanding pin is allowed to freely center itself to assume the largest size. The actual mating envelope and the real feature behave the same in a fit

situation but the AME is perfect and its axis is meaningful. When showing the theoretical gages, an expanding cylinder datum simulator will be shown as an axis with pair of arrows showing the direction of expanding.

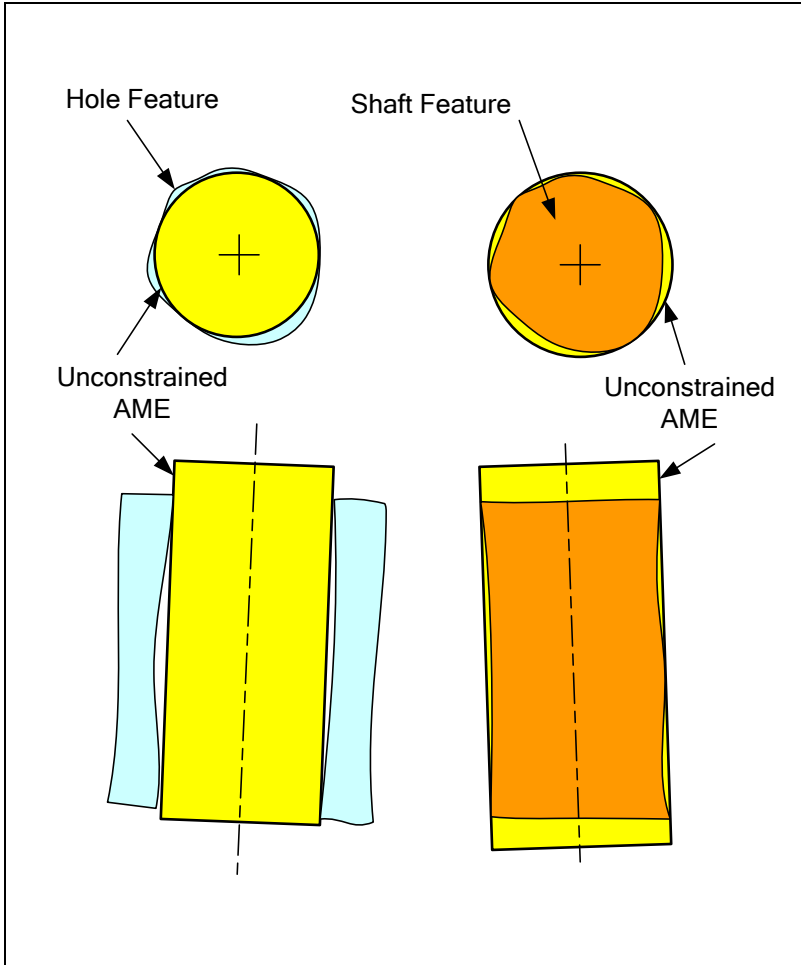
The tolerance zone geometry of the gage is a long cylindrical zone parallel to the axis of the datum simulator with a size equal to the tolerance value. For example, Figure 2-23 shows the theoretical gage for the specification shown in Figure 2-21. Axis-A, shown in the figure, is the axis of an expanding cylinder that fits into the datum cylinder during gaging. The arrows around the axis is an indicator that the axis is established by an expanding cylinder that grips the part.



**Figure 2-23. Theoretical gage for parallelism of a hole with respect to another hole**

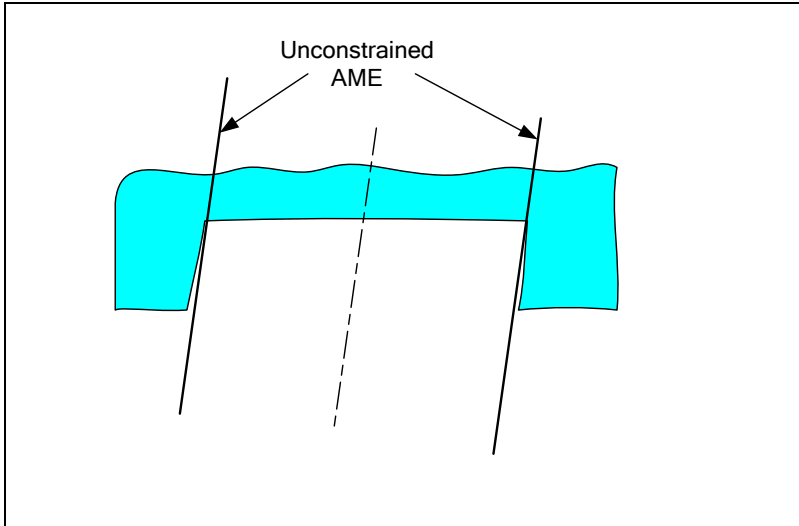
For the part staging, the part is constrained by an expanding pin (datum simulator) that fits inside the datum feature hole. Then, the axis of the subject feature's unconstrained AME is identified. This subject feature axis is checked for containment into the tolerance zone cylinder. The tolerance zone cylinder is free to translate parallel to Axis-A to the best location for axis containment check.

Figure 2-24 shows the unconstrained AME for a hole feature and also for a shaft feature. The unconstrained AME for a shaft is the smallest hole that fits over the shaft.



**Figure 2-24. Identifying the axis of a cylindrical feature using unconstrained AMEs**

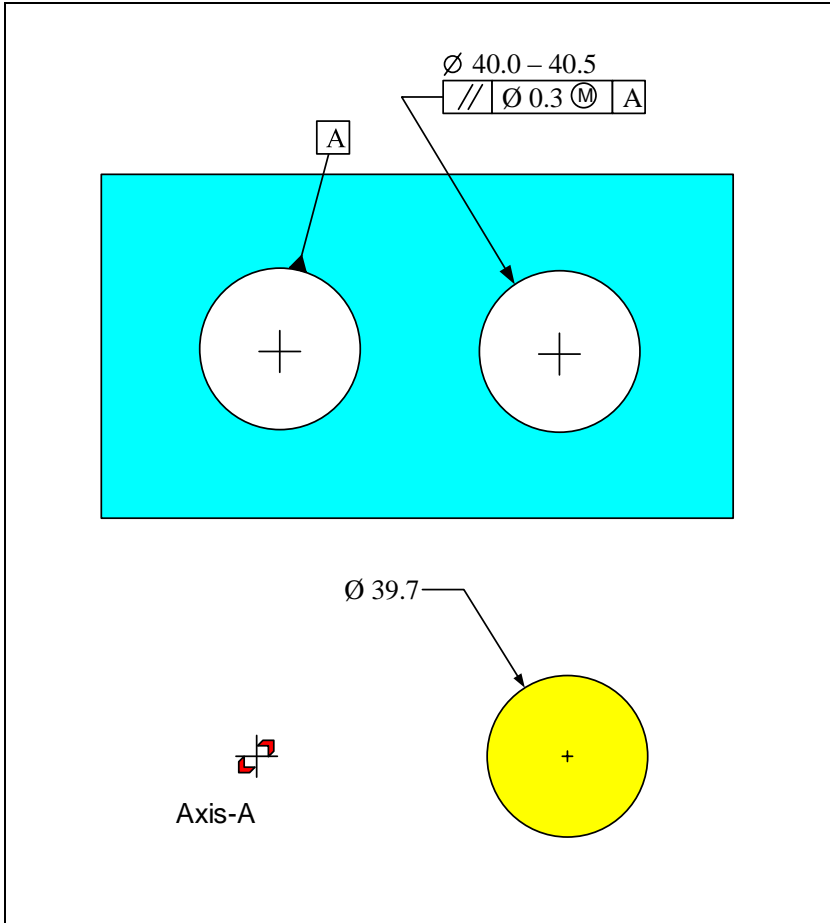
The concept of the actual mating envelope also applies to slot and rail features. In the case of slots and rails, the expanding or contracting cylinders are replaced by expanding or contracting parallel planes or jaws. Figure 2-25 shows the unconstrained AME for a slot feature.



**Figure 2-25. Identifying the center plane of a slot using unconstrained AME**

The unconstrained AME establishes the center plane of slot or rail features. As you may have guessed, there are also constrained AMEs which are only applicable to datum features when the tolerance statement includes multiple datum specifications. The axis or center plane of subject features, however, will always be the unconstrained AME. Constrained AMEs will be discussed when position tolerances are introduced in the next chapter.

When the tolerance value is followed by the  $\textcircled{M}$  modifier for a hole, the tolerance zone (acceptance zone) of the gage becomes a bar. Such a tolerance statement controls the combined effect of feature size and its axis deviation from perfect parallelism with respect to the datum axis. An example of a  $\textcircled{M}$  modified specification and the resulting theoretical gage is shown in Figure 2-26.

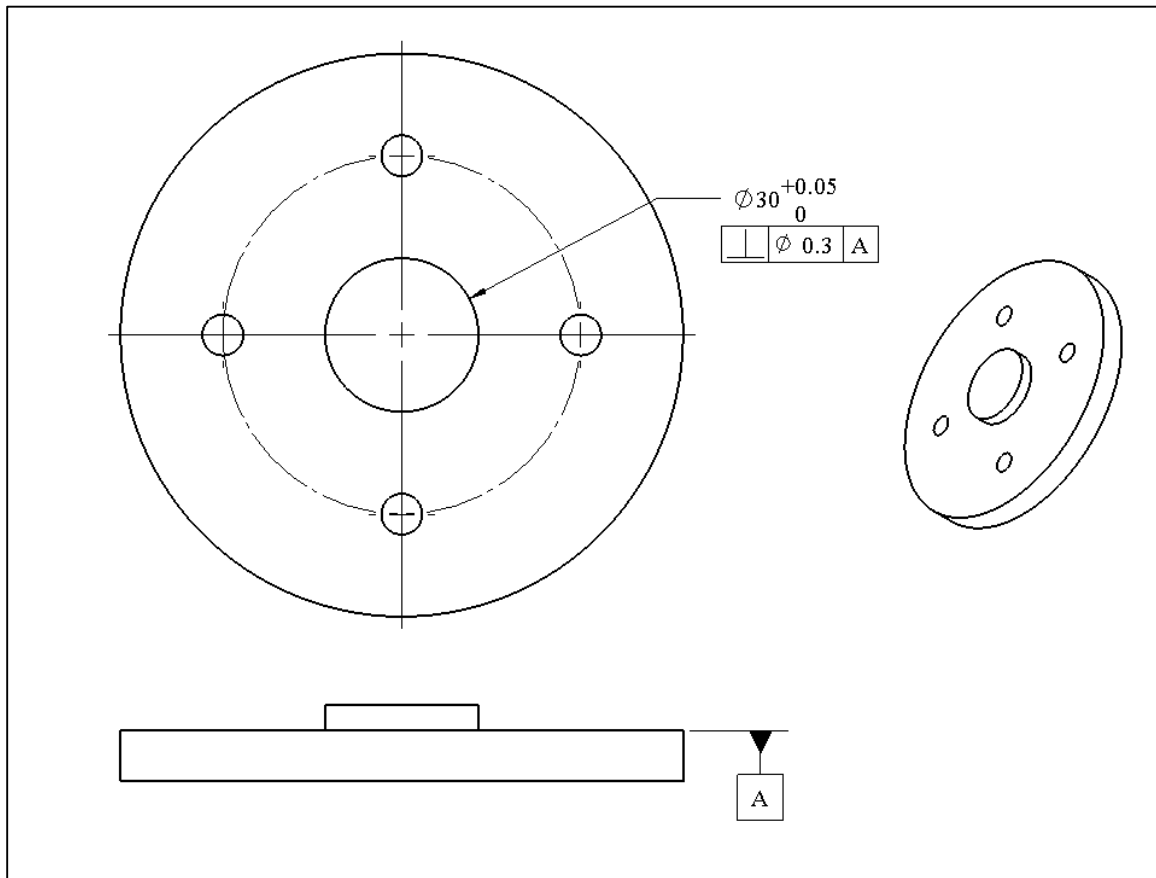


**Figure 2-26. A specification and the resulting gage when the  $\text{M}$  modifier is used on a hole subject feature**

After aligning the datum simulator axis of the gage with the actual datum feature axis through an expanding pin, the hole feature must fit over the gage acceptance zone (yellow pin). The acceptance zone is free to translate parallel to the datum axis. The size of the pin for a hole feature is 39.7mm which is equal to the smallest hole size (40 mm) minus the tolerance value (0.3 mm). When the actual hole is made to be larger (closer to 40.5 mm), the gage automatically allows it to be less parallel relative to the datum axis. When the pin is closer to 40 mm its axis has to be more parallel relative to the datum axis.

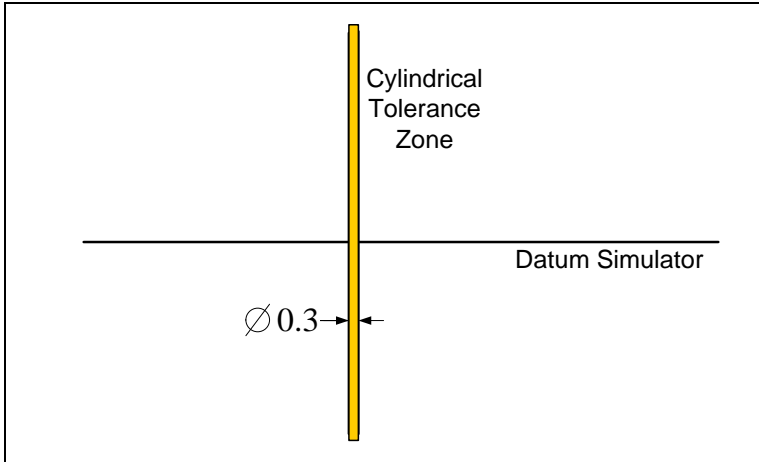
## 2.14. Perpendicularity $\perp$

Perpendicularity requires a surface or axis to be perpendicular to another reference surface or axis to within a specified tolerance value. The reference surface or axis is labeled as a datum. Figure 2-27 shows an example in which an axis is specified to be perpendicular to a planar feature.



**Figure 2-27. An example of perpendicularity tolerance specification**

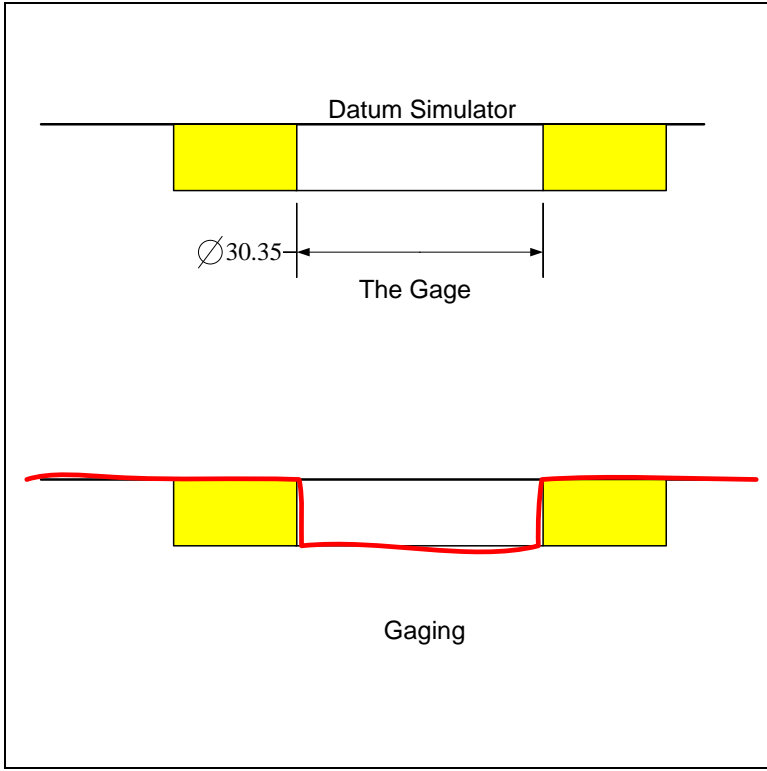
The interpretation of perpendicularity tolerance statement is similar to that of parallelism. The only difference is that the tolerance zone of the gage is perpendicular to the datum simulator plane or axis. The theoretical gage for the perpendicularity statement of Figure 2-27 is shown in Figure 2-28.



**Figure 2-28. The theoretical gage for axis perpendicularity statement**

The gaging process requires placing the datum feature of the part against the datum simulator and checking the axis of the boss feature for containment within the 0.3 mm diameter tolerance zone. The axis of the boss subject feature is established by its unconstrained AME.

If an  $\textcircled{M}$  modifier follows the tolerance value of Figure 2-27, the acceptance zone of the gage becomes a hole of size 30.35 mm. The gage controls the combined feature size and perpendicularity. Figure 2-29 shows the resulting gage and an example of gaging. The outline of an actual part is shown in red. This feature fits the acceptance zone of the gage while fully resting on the datum simulator.

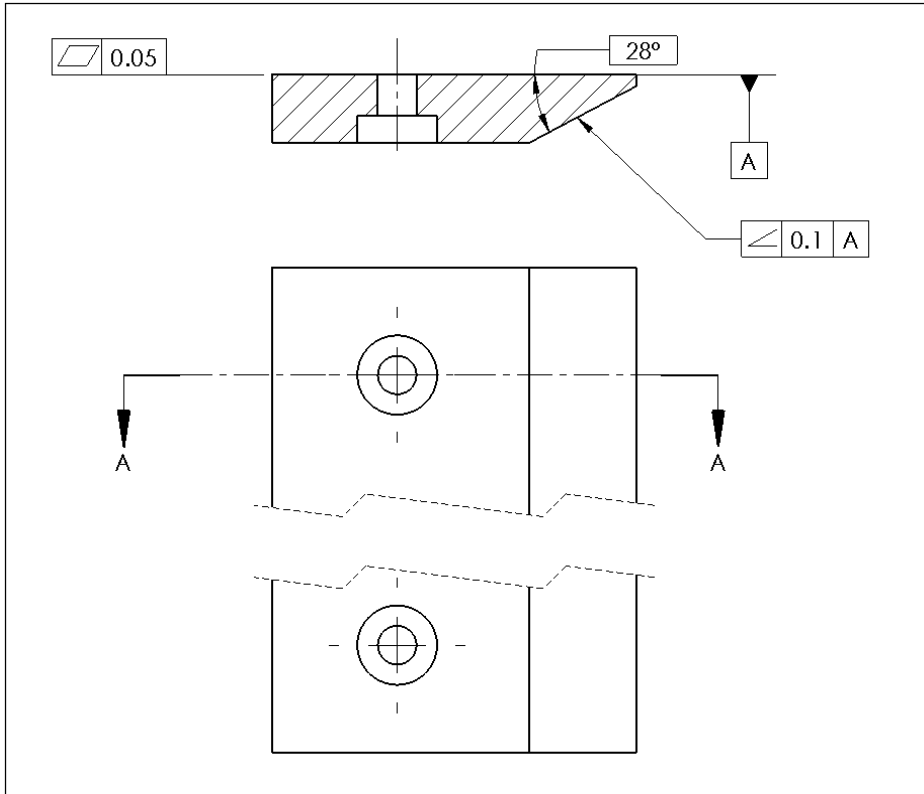


**Figure 2-29. The theoretical gage for axis perpendicularity statement when tolerance value is followed by an  $\text{M}$  symbol**

Note that the gage allows a pin made closer to its LMC size of 30 mm to have a larger orientation deviation than a pin closer to its MMC size of 30.05 mm.

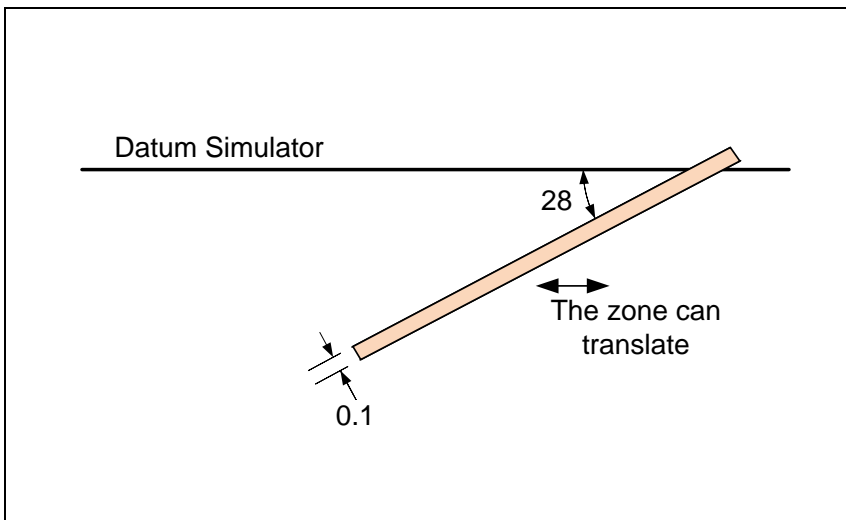
**2.15. Angularity**  $\square \angle$

Angularity requires a surface or axis to be at a certain orientation relative to another reference surface or axis to within a specified tolerance value. The reference is identified as a datum. Figure 2-30 shows a typical use of angularity for a planar feature.



**Figure 2-30. An example of angularity tolerance statement**

The gage for this angularity tolerance specification is shown in Figure 2-31.



**Figure 2-31. Theoretical gage for the angularity tolerance**

The interpretation of angularity follows the same procedure as parallelism and perpendicularity. For the angularity statement shown in the figure, the tolerance zone is a

pair of parallel planes with a 0.1 mm separation. This tolerance zone is oriented at an angle of 28 degrees relative to the datum simulator plane of the gage.

### Exercise Problems

1. Model the turning support part in a CAD system and create a drawing sheet as shown in Figure 2-32, excluding the labels.

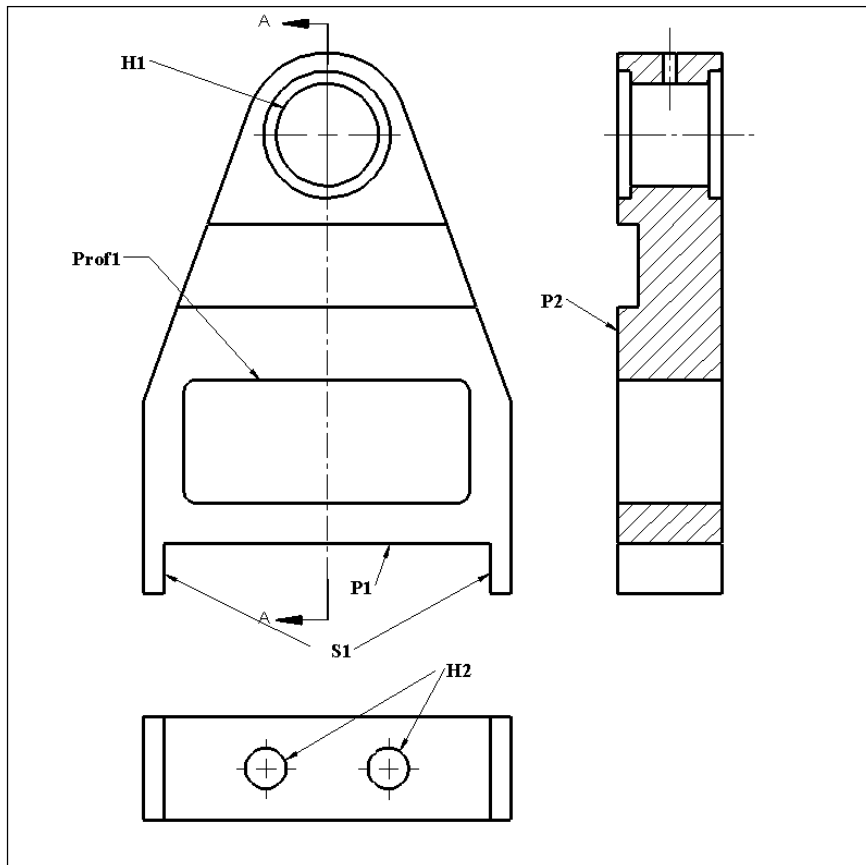


Figure 2-32. Turning support part

Using GDT standard annotation capacities of the CAD system, specify the following tolerances:

- a. Define plane  $P_1$  as Datum-A.
- b. Define slot  $S_1$  as Datum-B.
- c. Define plane  $P_2$  as Datum-C.
- d. Make Datum-A feature flat to within 0.02 mm.
- e. Make Datum-B perpendicular to Datum-A to within 0.05 mm.
- f. Make Datum-C perpendicular to Datum-A and Datum-B to within 0.1 mm.
- g. Specify the size limits of hole  $H_1$  to be  $20 \pm 0.02$  mm.
- h. Specify the size of slot  $S_1$  to be 76.00 – 76.15 mm.
- i. Specify the size of holes  $H_2$  to be 12.00 – 12.25 mm.
- j. Specify hole  $H_1$  to be parallel to plane  $P_1$ . Use a tolerance value of 0.1 mm.

2. Consider the turning support part shown in Figure 2-33. Draw the theoretical gages for the following:
  - a. The flatness specification.
  - b. The circularity specification.
  - c. The parallelism specification.
  - d. The perpendicularity specification.

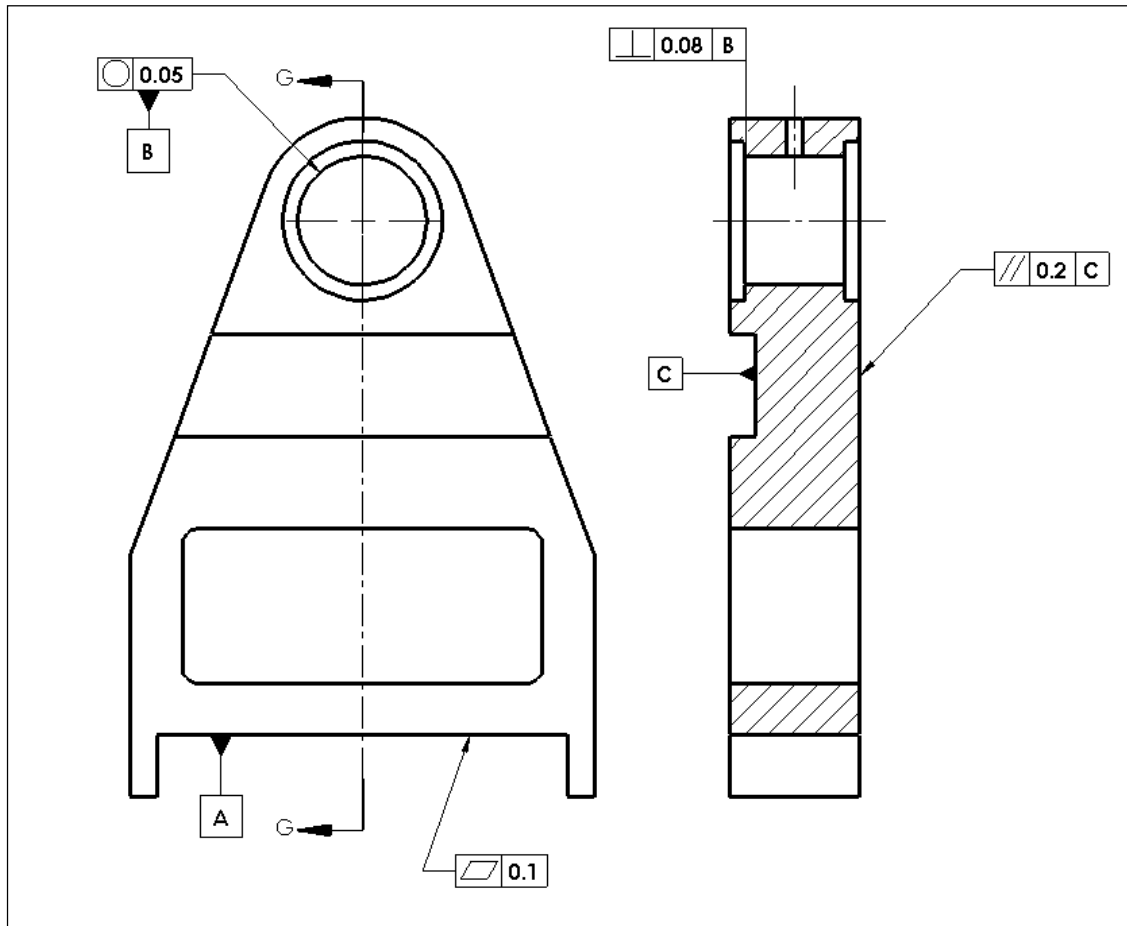


Figure 2-33. Turning support part

3. Consider the turning support part shown in Figure 2-34. Draw the theoretical gages for the following:
  - a. The straightness specification.
  - b. The parallelism specification.
  - c. The perpendicularity specification.
  - d. The cylindricity specification.

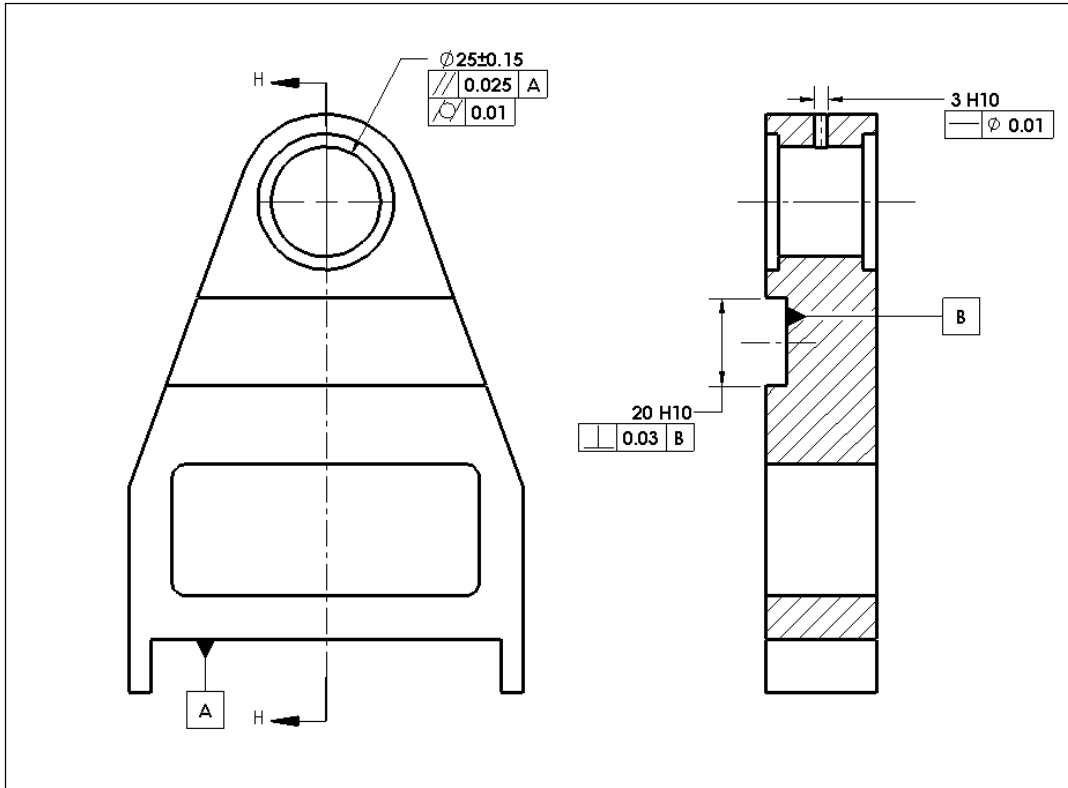


Figure 2-34. Turning support part

4. Consider the part shown in Figure 2-35.

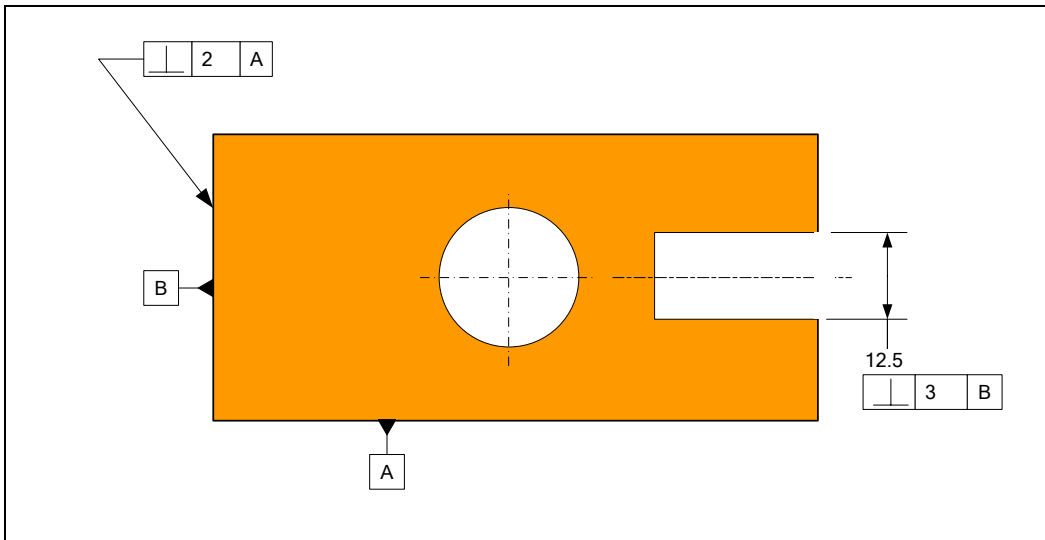
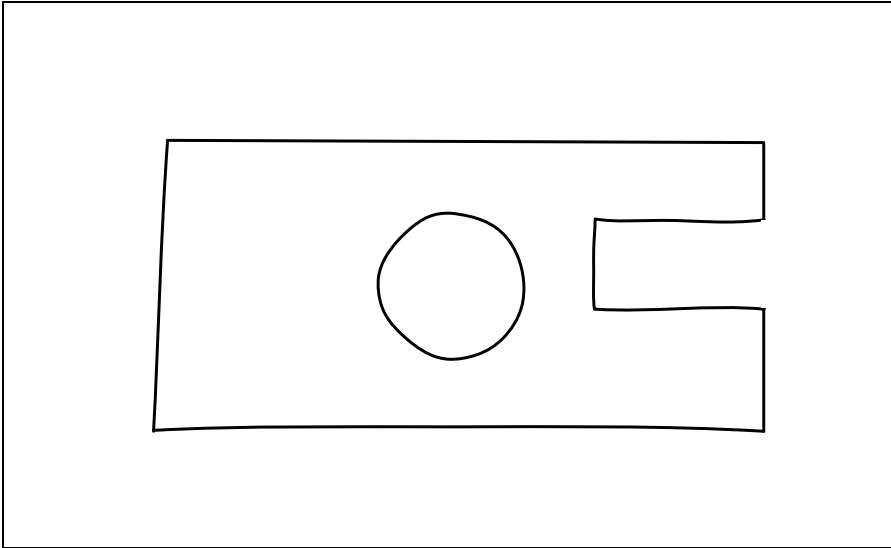


Figure 2-35. A 2D part drawing

The real part is shown in Figure 2-36.

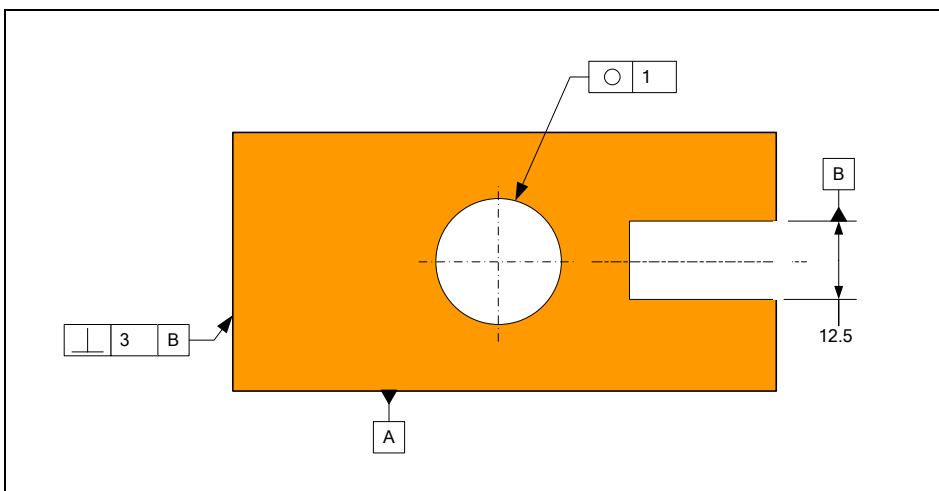
- a. Create theoretical gages for the two tolerance statements.

- b. Draw the perpendicularity gage for the slot feature on a transparency and check the real part for conformance. Is the orientation of the slot acceptable?
- c. Draw the perpendicularity gage for the planar feature on a transparency and check the real part for conformance. Is the orientation of the planar feature in the perpendicularity statement acceptable?



**Figure 2-36. A 2D manufactured part**

5. Consider the specifications shown in Figure 2-37.
  - a. Draw the gage for perpendicularity on a transparency and check for conformance.
  - b. Is the perpendicularity of the plane acceptable?
  - c. Check the circularity of the hole feature by drawing the circularity gage on a transparency and comparing it against the real part.



**Figure 2-37. A 2D part drawing**

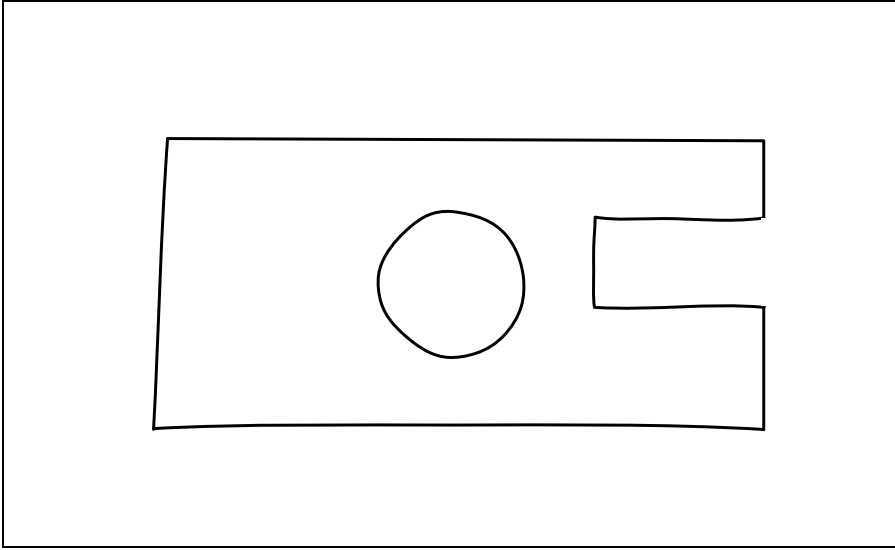


Figure 2-38. A 2D manufactured part

# Chapter -3

## A Design Engineer's Overview of Tolerance Statements - Part-II

### 3.1. Overview

This chapter presents the meaning of the remaining important tolerance statements including tolerances of location and profile tolerances. A gage that defines a tolerance of location must use at least one location dimension for its construction. Sometimes the location dimension is zero when the features are aligned such as with coaxial features. The location dimensions can also be the distances within a pattern of features.

### 3.2. Tolerances of location

Tolerances of location control the distance between a subject feature and one or more datum features. Tolerances of location fall into one of the types shown in Table 3-1.






Symbol	Specification	Typical Features	Frequency of Use
	Position tolerance	Single or pattern of cylinders Single or pattern of width features	*****
	Circular runout	Circular cross-sections (2D)	*****
	Total runout	Cylindrical features	***
	Concentricity	Circular cross-sections (2D)	*
	Symmetry	Cross-sections (2D)	*

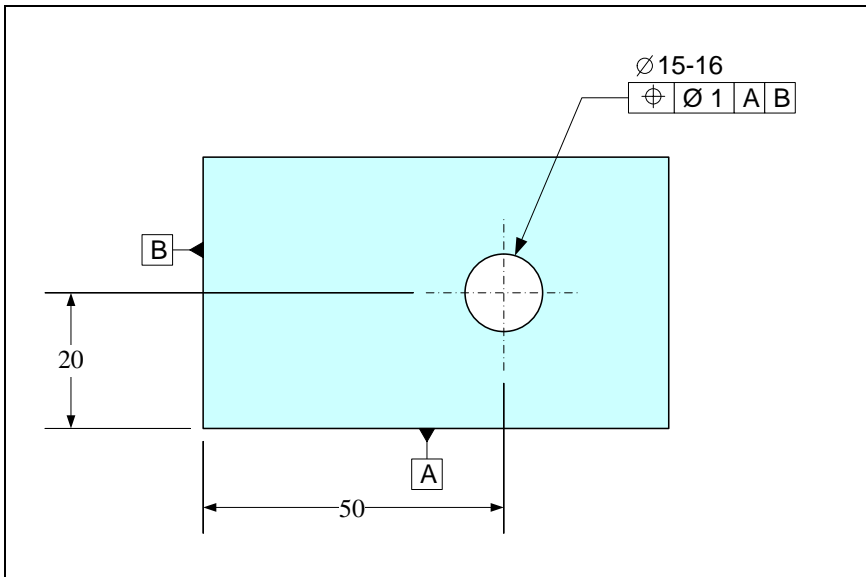
Table 3-1. Tolerances of location

### 3.3. Position tolerance



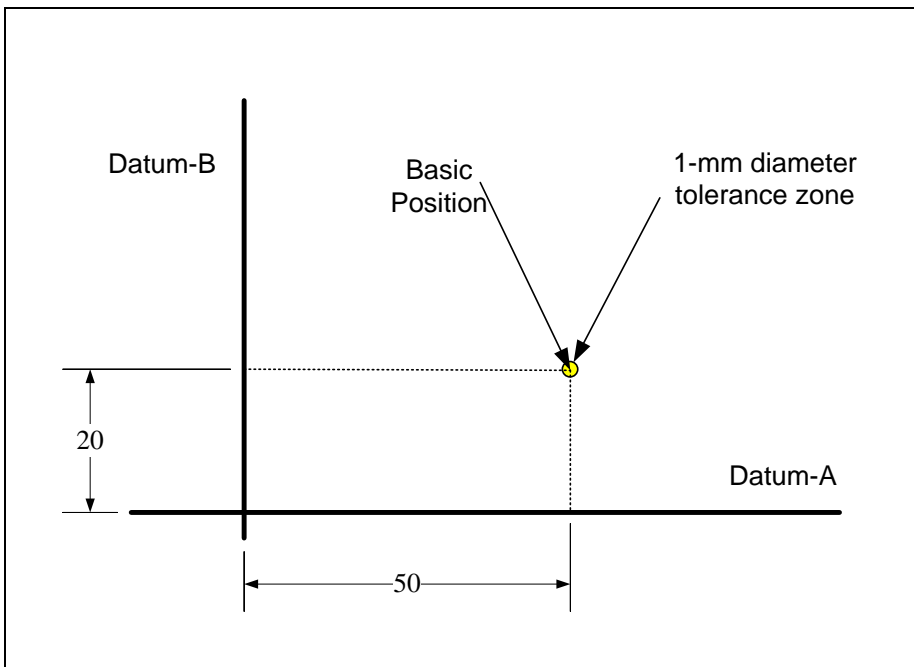
Position tolerance may be applied to features-of-size or their patterns. A pattern of features must have features with identical sizes and usually with identical functions. For single features, position tolerance requires the axis (or center plane) of a subject feature to be within a specified tolerance zone with respect to a datum frame. For patterns of features, the position statement additionally requires the relative locations within the pattern to be maintained with the same accuracy. The presentation here uses cylindrical subject features but the position tolerance also applies to width features. For width features, center planes substitute for the axes of cylindrical features.

Figure 3-1 shows a simple part with a position control statement. Assume the parts shown are plates with a constant thickness.



**Figure 3-1. Position tolerance applied to a single cylindrical feature**

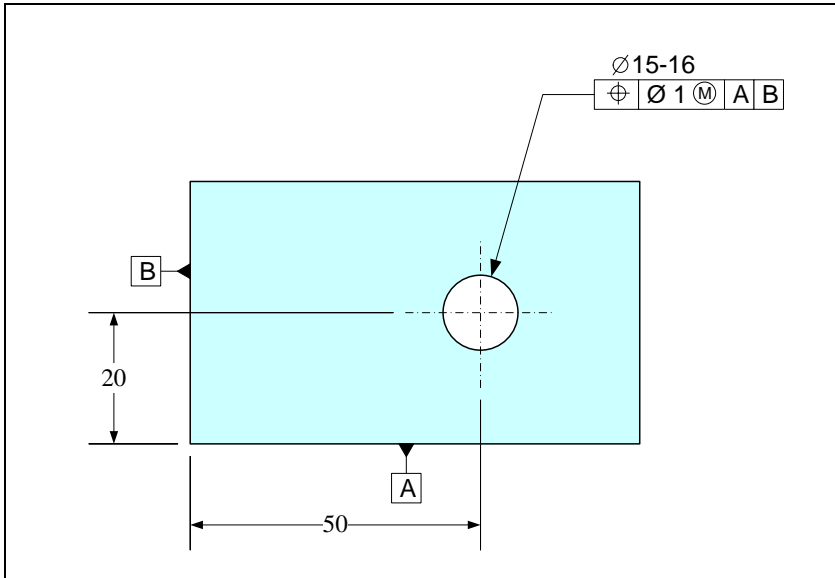
The theoretical gage for this position tolerance specification is shown in Figure 3-2. Datum-A and datum-B are datum feature simulators.



**Figure 3-2. The gage for the position tolerance applied to a single cylindrical feature**

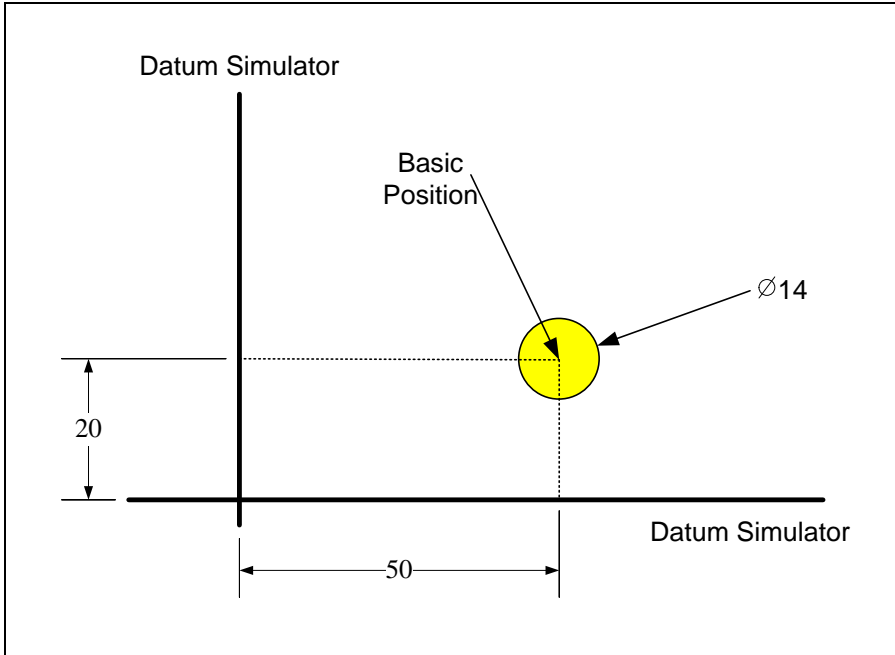
Since the position tolerance applies only to features-of-size the tolerance value can always be followed by an  $\textcircled{M}$  or  $\textcircled{L}$  modifier. The position tolerance statement with

modifiers are used to control the combined effect of size and position deviation. Figure 3-3 shows an example of an  $\textcircled{M}$ -modified tolerance value.



**Figure 3-3. An example of an  $\textcircled{M}$  modified position tolerance specification**

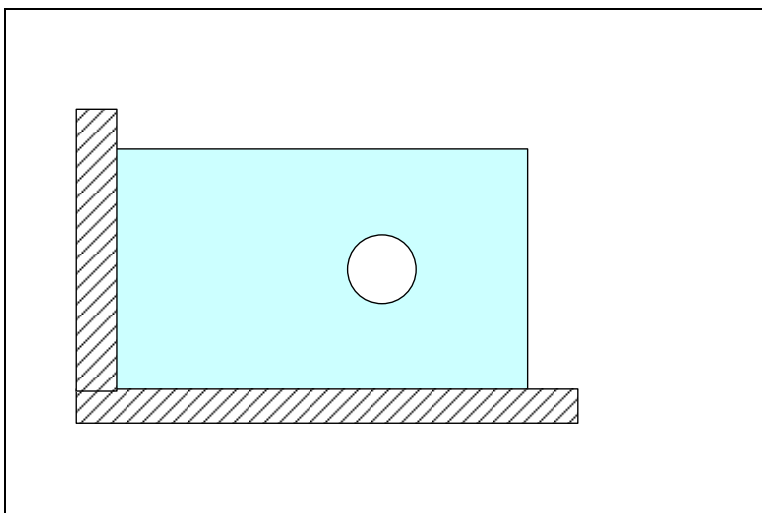
For an  $\textcircled{M}$ -modified tolerance statement, the acceptance zone of the gage becomes a boss as shown in Figure 3-4. The size of the boss is equal to the minimum size of the hole (15 mm) minus the tolerance value (1 mm) resulting in a 14 mm boss. The gage allows a hole closer to its LMC size of 16 mm to deviate more from the theoretical position than a hole made closer to its MMC size 15 mm.



**Figure 3-4. The tolerance zone is located at the basic position with respect to the datum frame**

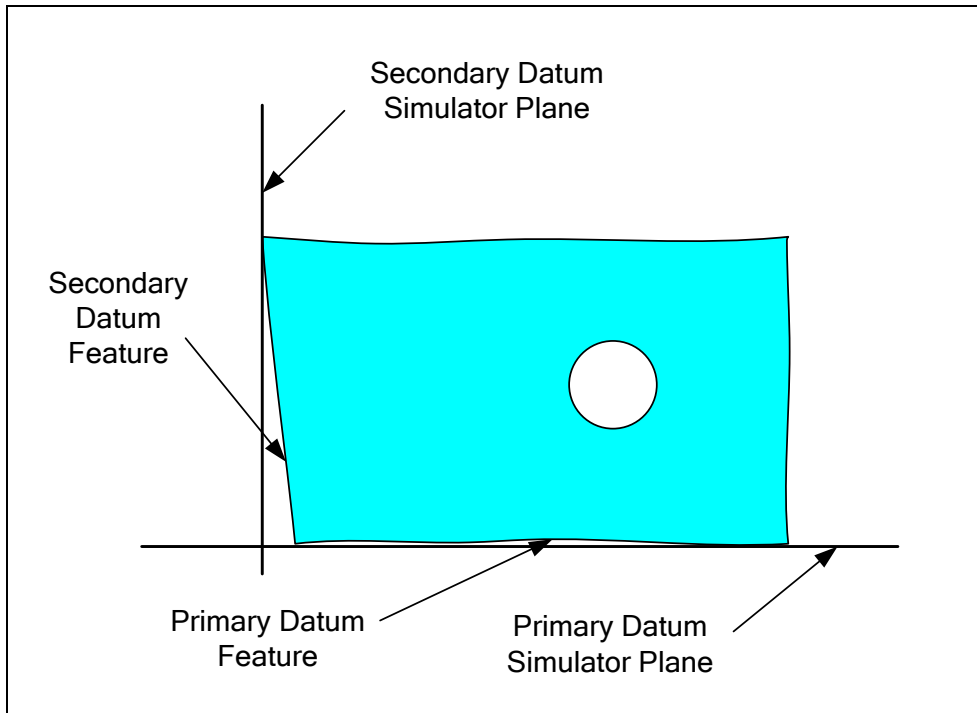
When multiple datum features are used in a tolerance statement, datum references are placed in the tolerance control box and their order or priority is assigned from left to right. The datum priority makes a difference in the manner of gaging but the gage itself is unaffected by the datum ordering. Up to three datums can be referenced in a position tolerance statement. The first datum is called the primary datum, the next one, if specified, is the secondary datum, and the third one, if specified, is the tertiary datum.

The datum features and datum priority mimic the way the part is intended to be fixed to an assembly. Figure 3-5 shows a final desired arrangement of a part into an assembly.



**Figure 3-5. The intended arrangement of part contact to the mating part**

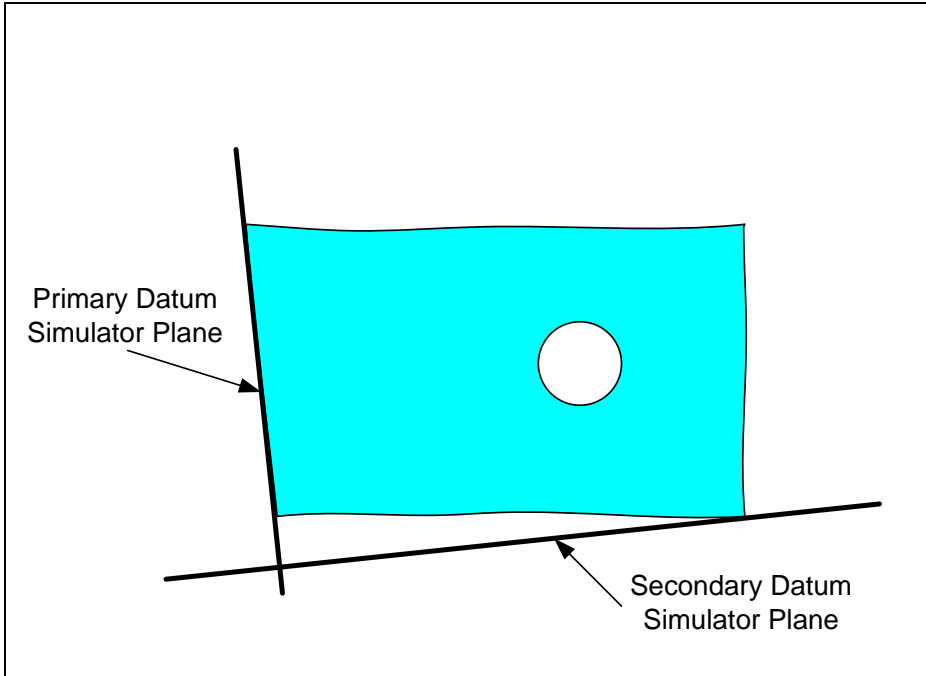
Each datum reference in a tolerance statement leads to a corresponding datum simulator on the theoretical gage. These datum simulators represent the perfect-form and perfect-orientation mating surfaces. The procedure for constraining the part to the gage is stated through the order of datum specification and illustrated in Figure 3-6.



**Figure 3-6. The procedure for constraining the part against datum simulators**

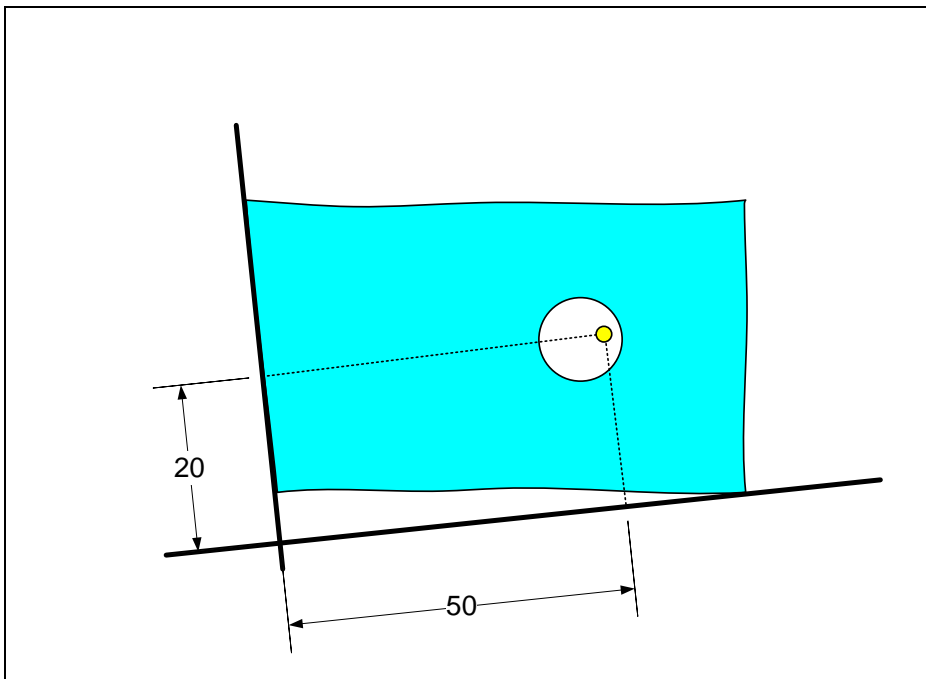
The primary datum simulator makes full unconstrained contact with its datum feature on the part. The secondary datum contact would not have an unconstrained contact because the part is required to remain in contact with the primary datum simulator. If the manufactured part had perfectly perpendicular datum features, then the datum priority would have made no difference when placing the part into assembly.

Figure 3-7 shows the actual arrangement of the part relative to the datum simulators when the datum priority is reversed. This change of datuming priority leads to a completely different part staging. In this case, datum-B surface orients the part.



**Figure 3-7.** The actual arrangement of part against the datum simulators when the side plane is the primary datum

Once the part is constrained to the datum simulators, the subject feature axis can be checked against the tolerance zone of the theoretical gage as shown in Figure 3-8. The basic position is the theoretical position of the hole axis with respect to the datum frame. The basic position is where the axis should be for a perfect placement.



**Figure 3-8.** The tolerance zone is located at the basic position with respect to the datum frame

In the case of Figure 3-8, the hole position is out of tolerance. Since simulators represent the mating surfaces on which the part contacts, the selection of the datum priority is such that it mimics the final assembly. When a part is being installed into an assembly it can only make full unconstrained contact on one surface. The next contact is going to be partially constrained by the first primary contact. For example, if datum-A plane is fixed to its mating plane by screws, then datum-A plane would be the primary datum. If datum-B plane is screwed to its mating part when it is installed in the assembly, then datum-B plane should be specified as the primary datum. If the design requires both surfaces to be screwed to mating surfaces, then the datum surfaces must be specified to be perpendicular with high precision. In that case it makes no difference which datum is selected to be the primary datum.

Figure 3-9 shows another example of a position tolerance involving a bearing hole controlled with respect to two datum references. The 25H7 designation is a coded way of stating the size limits of the hole. The 25H7 numerical limits are 25.000 – 25.021 mm. Coded size limits will be presented later in Chapter-6.

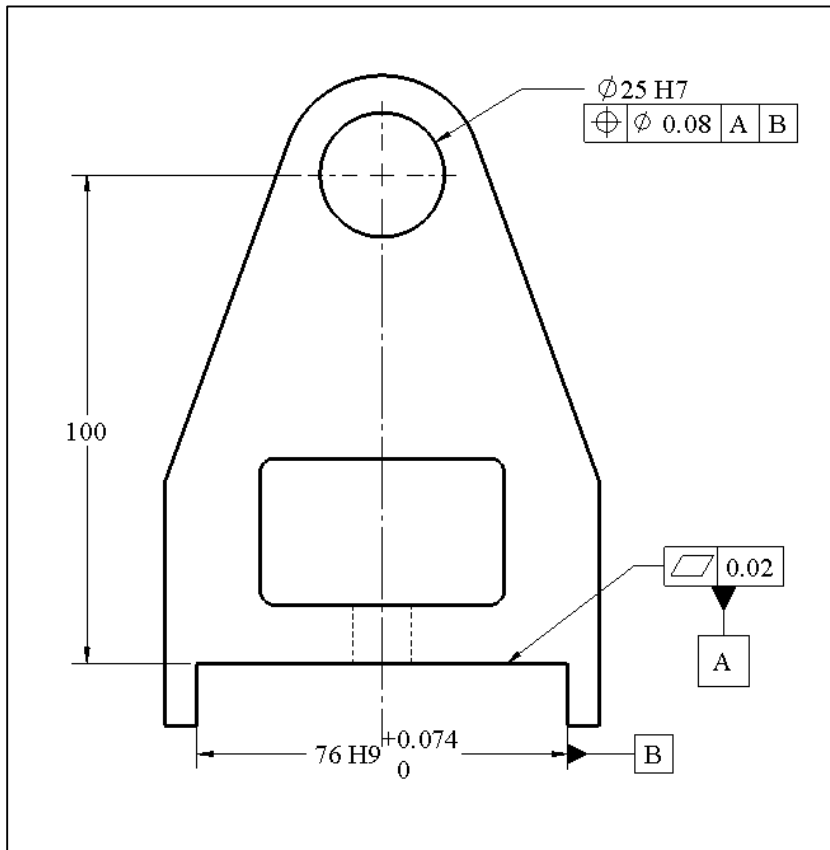
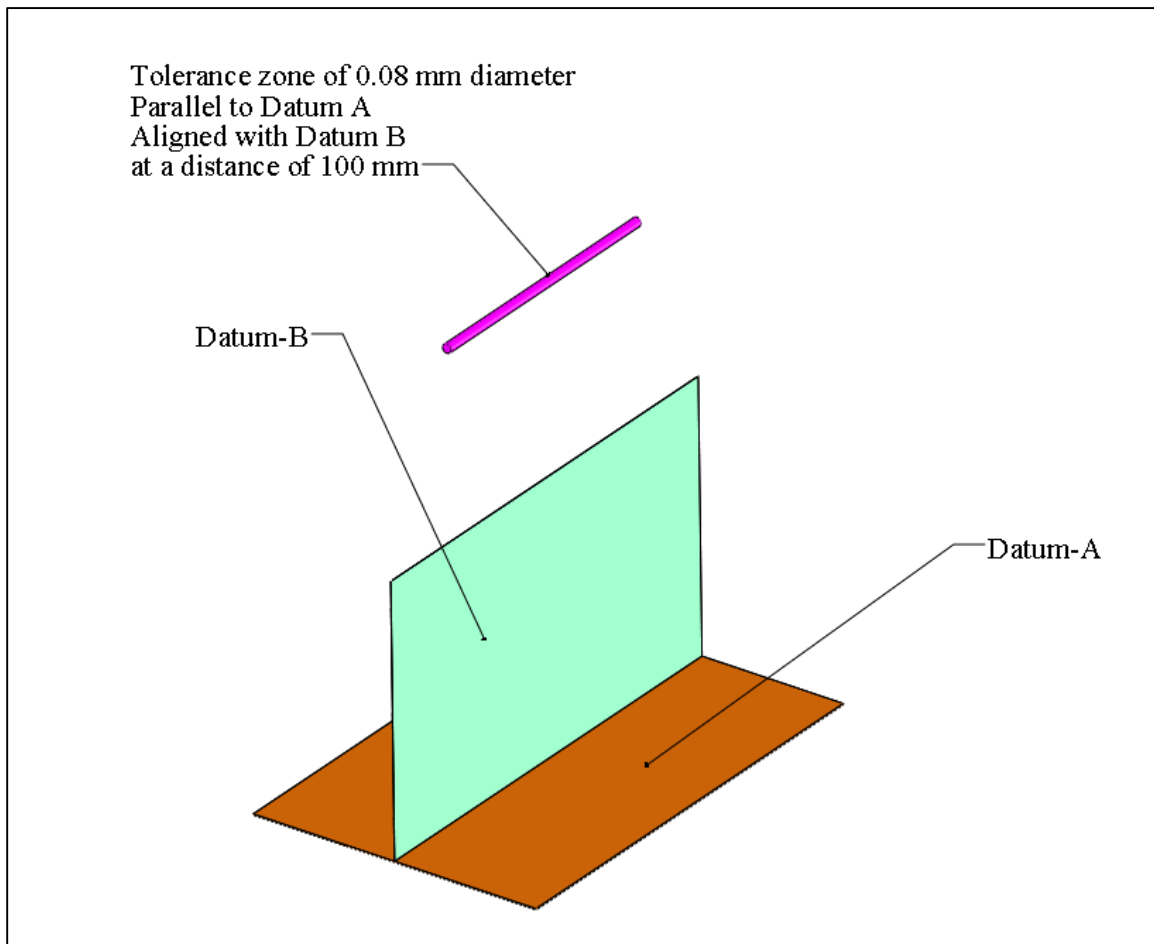


Figure 3-9. An example of position tolerance statement

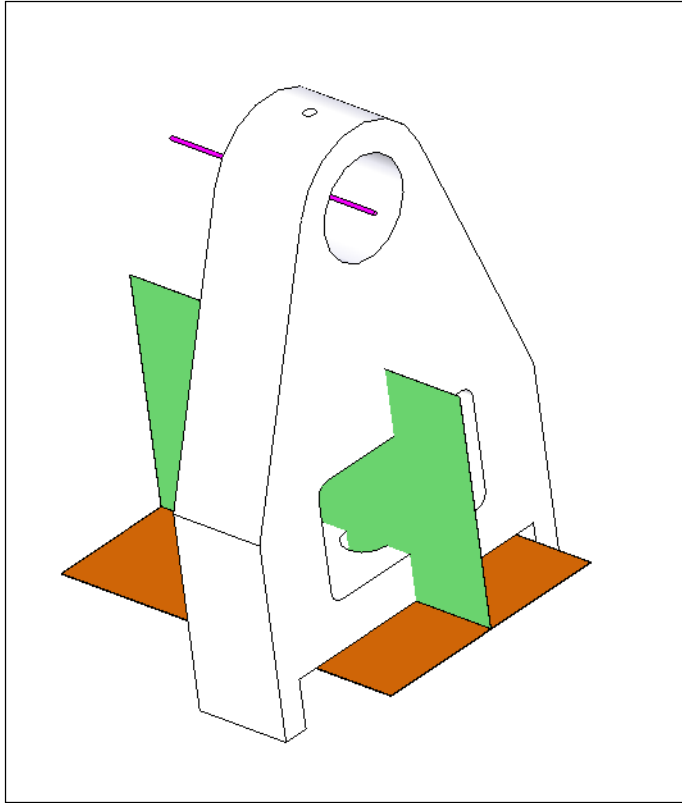
In this example, datum-A is the primary datum. Datum-B, the secondary datum, is the center plane of the slot. To specify the center plane as the datum, the datum symbol must be aligned and attached to the dimension line. The axis of the bearing hole is

required to be parallel to and at a precise distance from datum-A. The bearing hole is also required to be centered relative to the slot center plane identified as datum-B. The datum simulator for datum-A is a plane and the datum simulator for datum-B is a pair of expanding jaws that grip the part. The expanding pair of jaws, however, must remain perpendicular to the primary datum-A simulator as the jaws open. Rather than showing the expanding pair of jaw datum simulators, the center plane of the expanding jaws will be shown in the theoretical gages. The theoretical gage for this statement is shown in Figure 3-10.



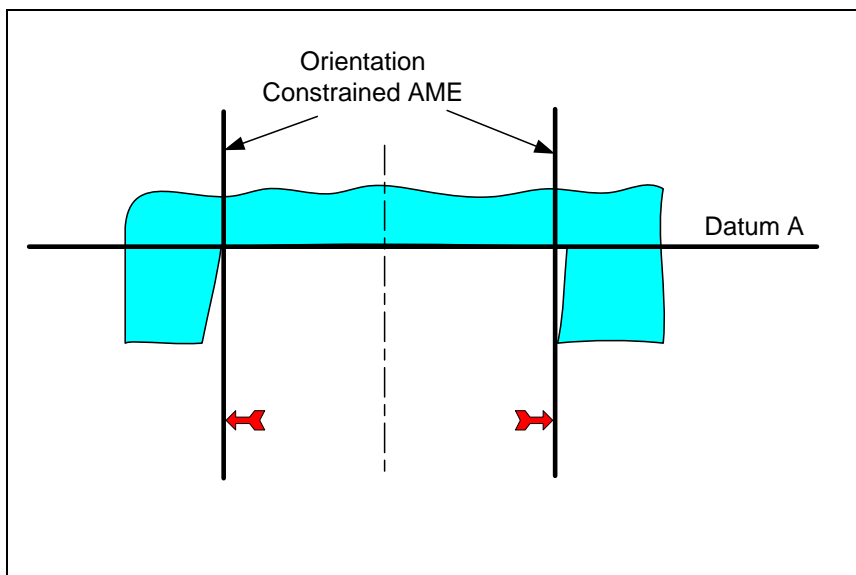
**Figure 3-10. The theoretical gage**

In the theoretical gaging procedure, which is shown in Figure 3-11, first the bottom surface of the part is pressed against the datum-A simulator of the gage just like a part is placed into a mating part surface of an assembly. Next, the parallel jaws of datum-B simulator grip the part as they open to fit inside the slot datum feature. The datum-B simulator mimics the slot fitting tightly into a mating rail.



**Figure 3-11. Theoretical gaging procedure requires constraining the part to the datum planes and checking the subject feature axis for containment within the tolerance zone**

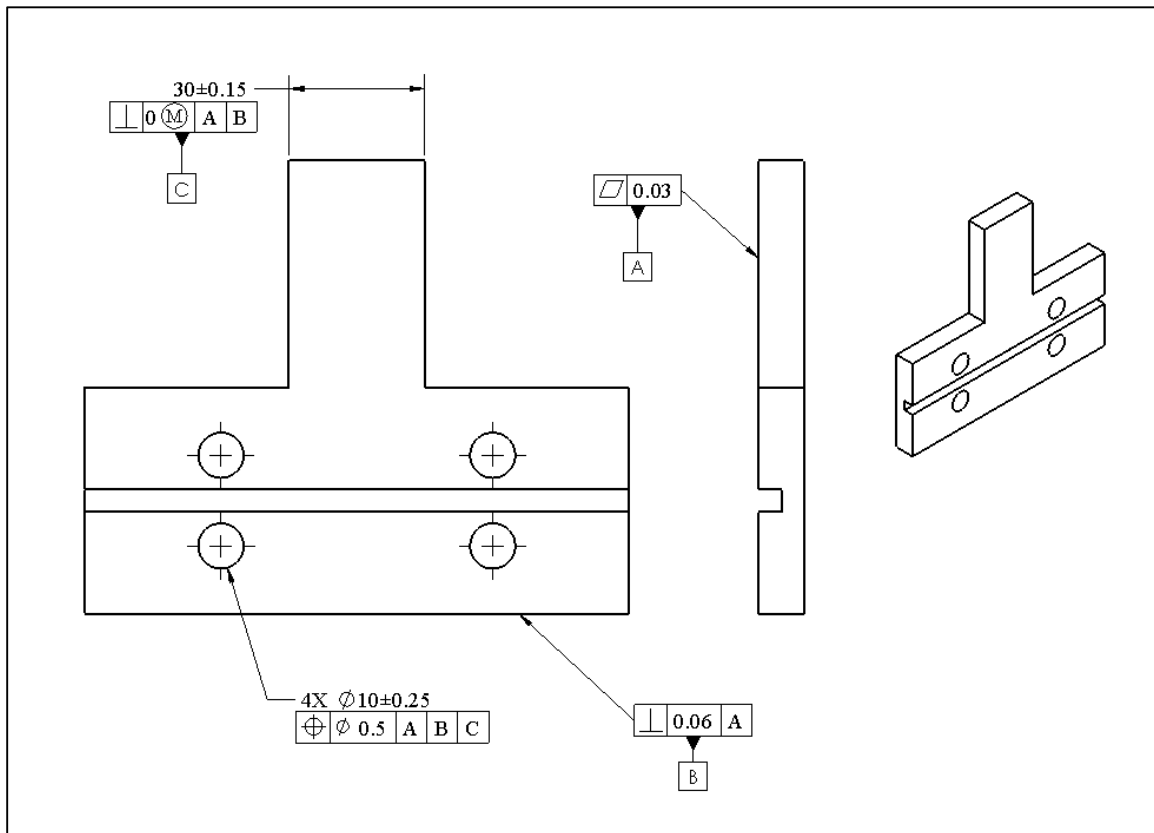
Figure 3-12 shows a pair of expanding jaws (parallel planes) gripping the slot. The resulting boundary (when the jaws can no longer expand) is the orientation-constrained actual mating envelope (orientation-constrained AME) of the slot.



**Figure 3-12. The orientation-constrained actual mating envelope for a slot**

After the part is aligned to datum simulators, the axis of the bearing hole is checked for containment against the tolerance zone cylinder. The axis of the bearing hole (subject feature) is always established by the axis of its unconstrained AME (the largest expanding cylinder fitting inside the bearing hole). However, if the tolerance is  $\textcircled{M}$  modified, the hole must clear an acceptance bar of size 24.92 mm. The bar size is equal to the MMC size of the hole (25 mm) minus the tolerance value (0.08 mm).

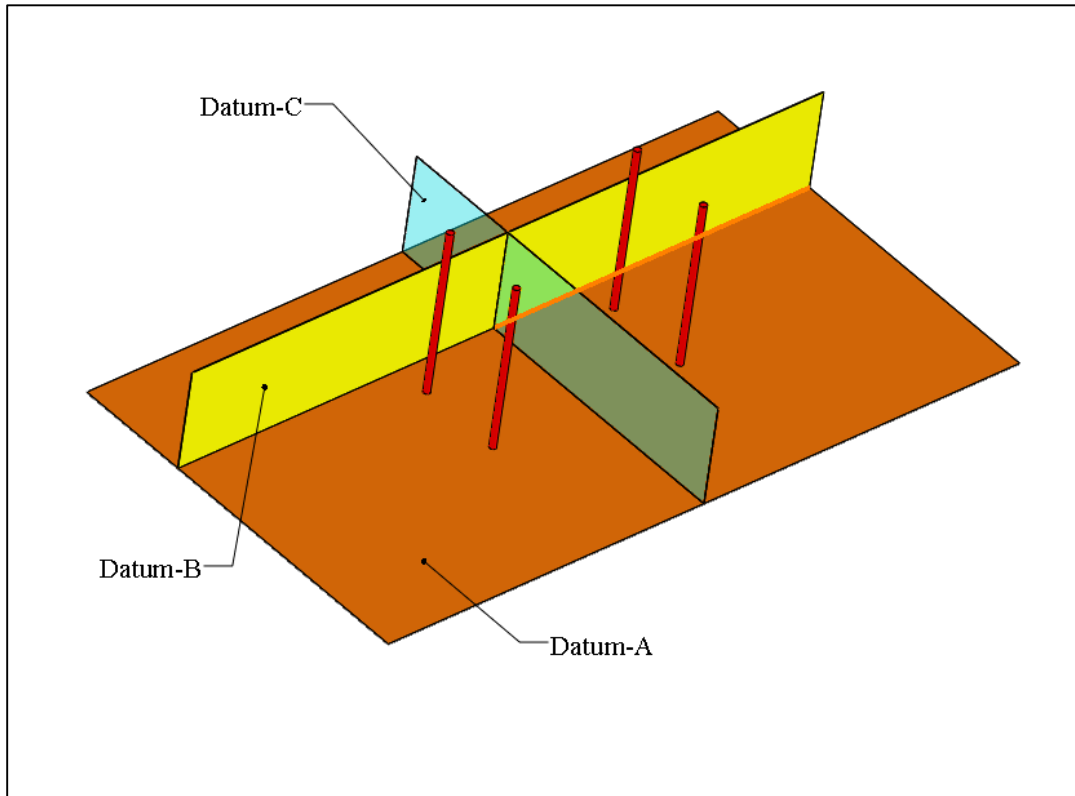
Position tolerance is frequently used to control the position of pattern of holes, or center planes of slots, with respect to datum features. The position tolerance also controls the relative locations of the features within the pattern. Figure 3-13 shows a pattern of four holes and a position tolerance statement applied to the pattern.



**Figure 3-13. Position tolerance controlling a pattern of holes**

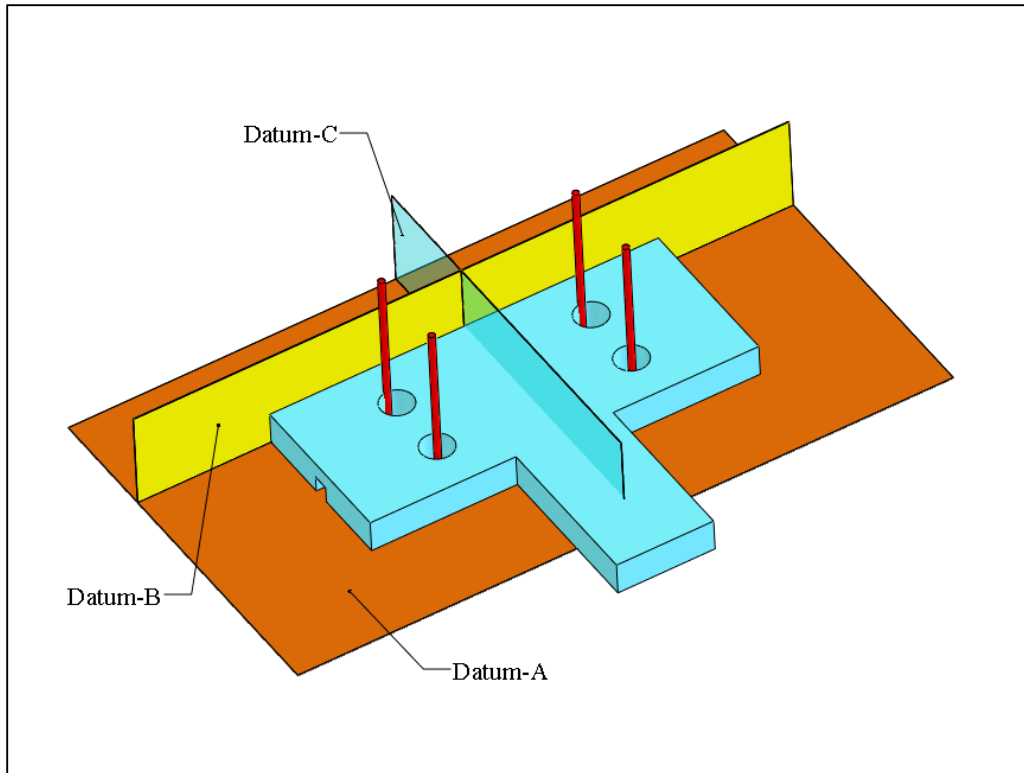
The pattern of four holes is to be primarily perpendicular to the surface designated as datum-A. A primary datum plane is commonly referred to as the *primary orienting datum* although it also locates features as well. When starting to tolerance a part for fit, the first question you should ask is “what surface orients this part with respect to the mating part or assembly?” Do not underestimate the importance of the primary orienting datum. When parts do not fit together the cause is often traced to incorrect selection of the primary orienting datum. In this example, the pattern must also be precisely located with respect to the top plane designated as datum-B. A secondary datum surface is

commonly referred to as the *secondary locating datum*. Finally, the pattern must be precisely centered with respect to the center plane of the rail feature designated as datum-C sometimes called the *tertiary locating datum*. Figure 3-14 shows the resulting theoretical gage. Do not be alarmed by the zero tolerance value in the perpendicularity tolerance. A zero geometric tolerance value is not an error when used with an  $\textcircled{M}$  or  $\textcircled{L}$  modifier.



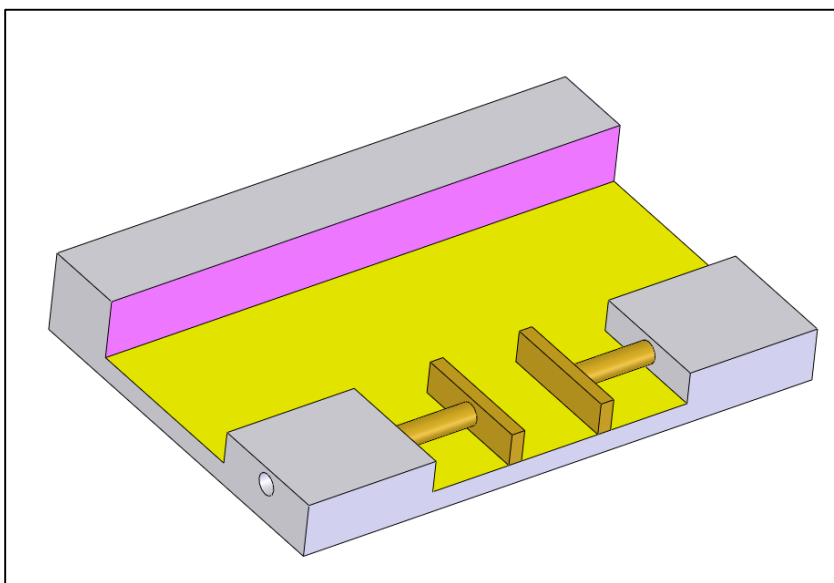
**Figure 3-14. The theoretical gage for inspecting the pattern position tolerance statement**

The gage is composed of three mutually perpendicular planes. Datums-A and datum-B are contacting datum simulators while datum-C represents the center plane of collapsing jaws that grip the datum-C rail. The pattern of four tolerance cylinders has a theoretical distance relationship with datum-B and datum-C planes. Tolerance cylinders have 0.5 mm diameters. Figure 3-15 shows how the gage is aligned to the part to check the position accuracy of the hole pattern. The datum simulator for the rail feature, datum-C, is a pair of collapsing jaws that must remain perpendicular to datum simulator plane A and datum simulator plane B. The theoretical gage shows the center plane of the jaws after they fully grip the part.



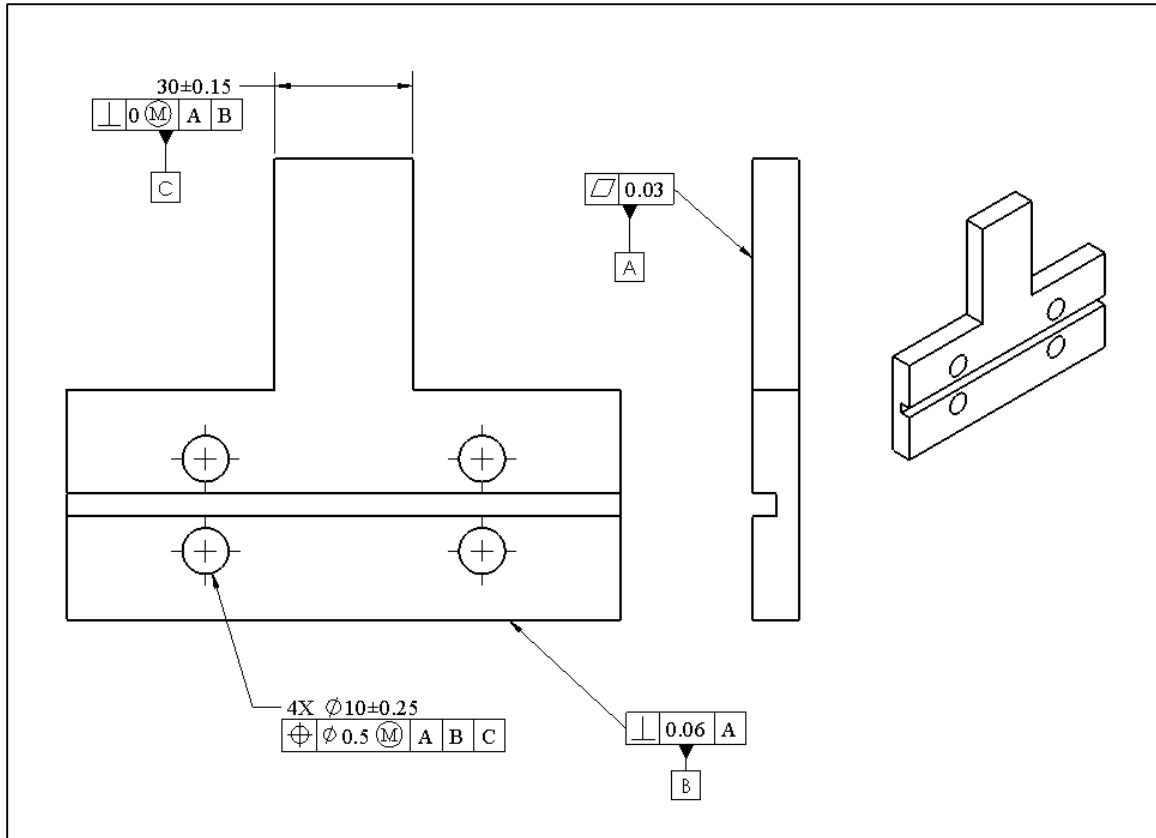
**Figure 3-15. The theoretical gaging for inspecting the pattern position tolerance statement**

In this example the datum frame completely fixes the part to the gage. Judging from Figure 3-15, two of the holes in the pattern are clearly off position. Figure 3-16 shows the datum simulators of a physical gage.



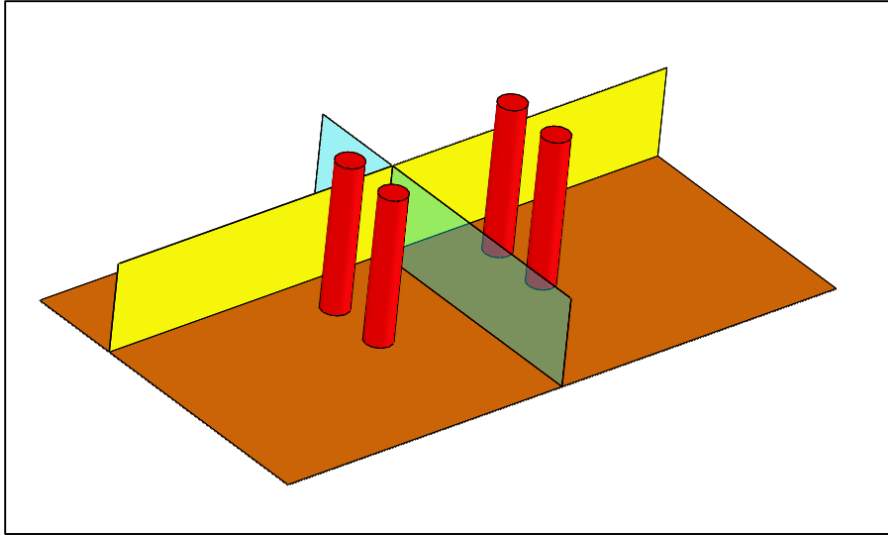
**Figure 3-16. A physical gage showing only the three datum simulators**

If an  $\textcircled{M}$  modifier follows the tolerance value as indicated in Figure 3-17, the tolerance zones change to a pattern of acceptance bars. The  $\textcircled{M}$  modified specification controls the combined effect of size and position deviations. The gage automatically allows larger holes to be off position more than the smaller holes.



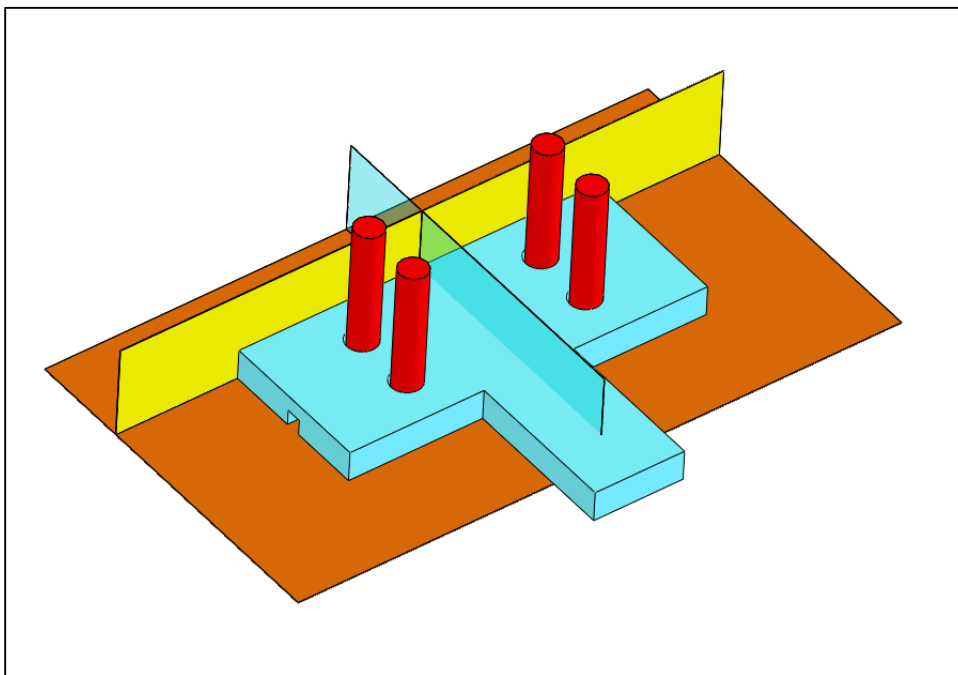
**Figure 3-17. Position tolerance controlling a pattern of holes using  $\textcircled{M}$  modifier**

The resulting theoretical gage is shown in Figure 3-18. The gage appears more realistic now as a mating part compared to the gage with tiny laser beam tolerance zones. The size of each bar is 9.25 mm.



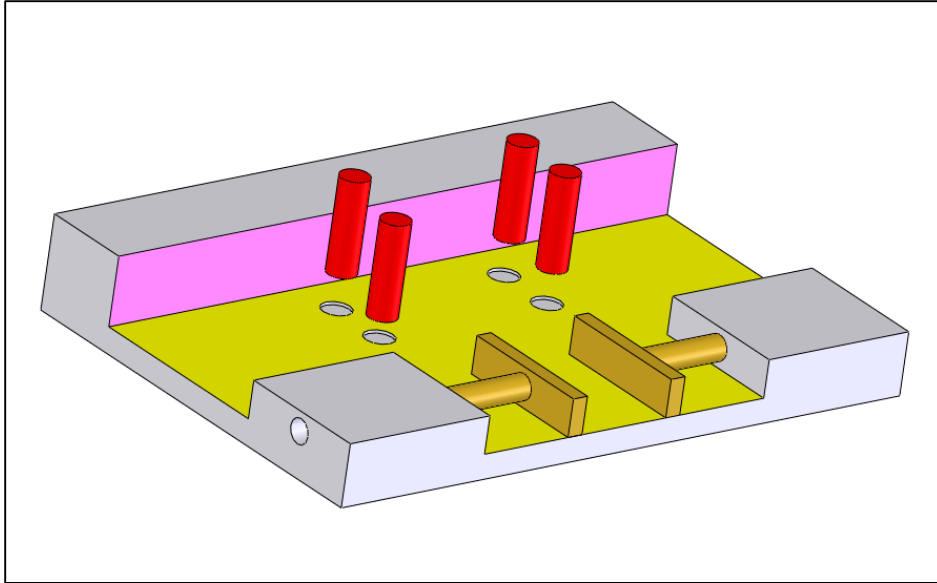
**Figure 3-18. The theoretical gage for the  $\text{\textcircled{M}}$  modified pattern position tolerance**

Figure 3-19 shows the theoretical gage and the gaging process. The hole features are acceptable if they all clear the gage bars.



**Figure 3-19. The theoretical gaging for inspecting the pattern position tolerance statement**

A physical gage simulating the theoretical gage and the gaging procedure can be constructed as shown in Figure 3-20. The loose pins are used to make the physical gaging practical.

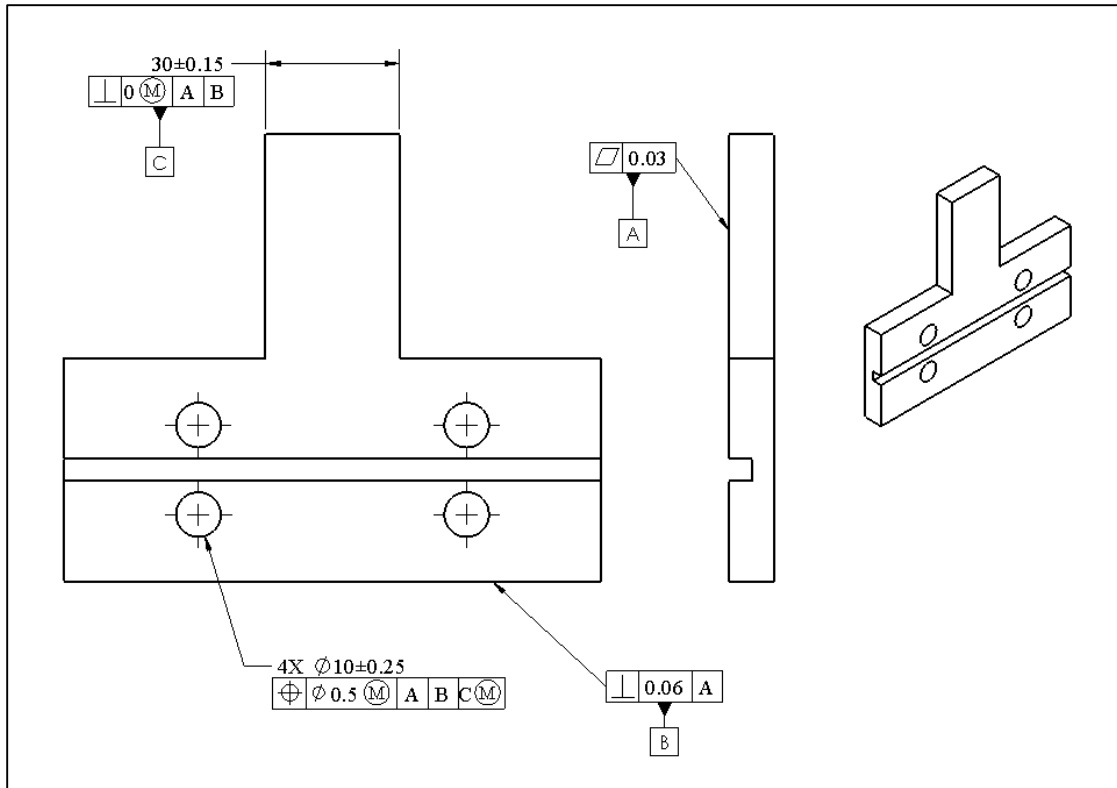


**Figure 3-20. A physical gage for inspecting  $\textcircled{M}$  modified position tolerance**

After the part is placed on the datum-A simulator plane and pushed against datum-B, the jaws move to grip the part to complete datum alignment or staging. As the jaws grip the part the part must remain in full primary contact with datum-A surface and secondary contact with datum-B surface. The inspector then attempts to insert the pins into their sockets that have the same sizes as the pins. If all the pins fit into their sockets, the pattern geometry is acceptable regarding the position tolerance. The jaws must be designed such that they move together the same amount. This ensures the hole pattern will always remain centered to the jaw's center plane.

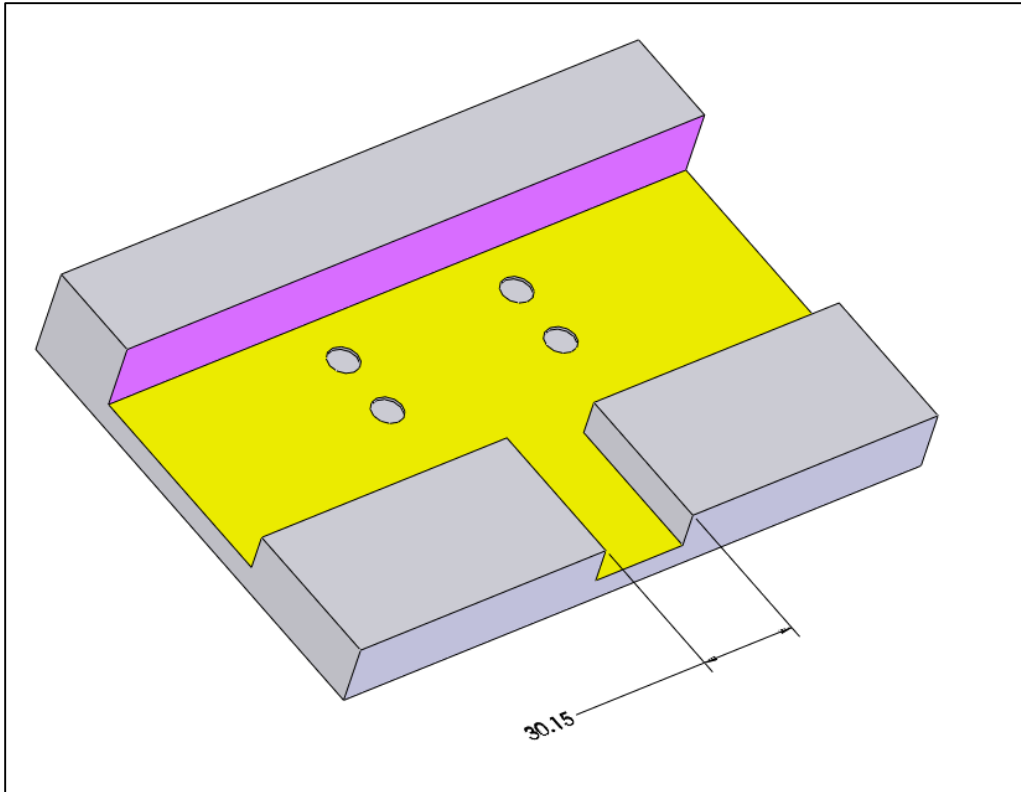
### **3.4. Meaning of $\textcircled{M}$ modifier applied to datum features**

It was mentioned that datums simply mimic the constraining surfaces of an assembly as the part is placed into the assembly. When a datum feature referenced in a tolerance statement is a feature-of-size and intended to fit a mating feature, it is most likely a rigid feature. The designer can apply a material condition modifier to such a datum. When an  $\textcircled{M}$  modifier follows the datum label in the tolerance statement, the datum is said to apply at its maximum material boundary (MMB). An example is shown in Figure 3-21.



**Figure 3-21. A position tolerance statement with an MMB datum specification**

A referenced datum feature with an (M) material condition modifier establishes a fixed size datum simulator. The size of the datum simulator is determined using the same formula as the size of (M) modified subject feature acceptance zones were determined. In this case, the size of the datum simulator slot for datum-C is 30.15 mm. The size of datum-C is obtained by adding the rail's MMC size of 30.15 mm to its tolerance of zero at MMC. Figure 3-22 shows the physical gage for the inspection of the part with MMB specification for datum-C. As you can see this is a more realistic representation of a mating part compared to one with the expanding jaws.



**Figure 3-22. A physical gage for inspecting position tolerance with  $\textcircled{M}$  modified datum**

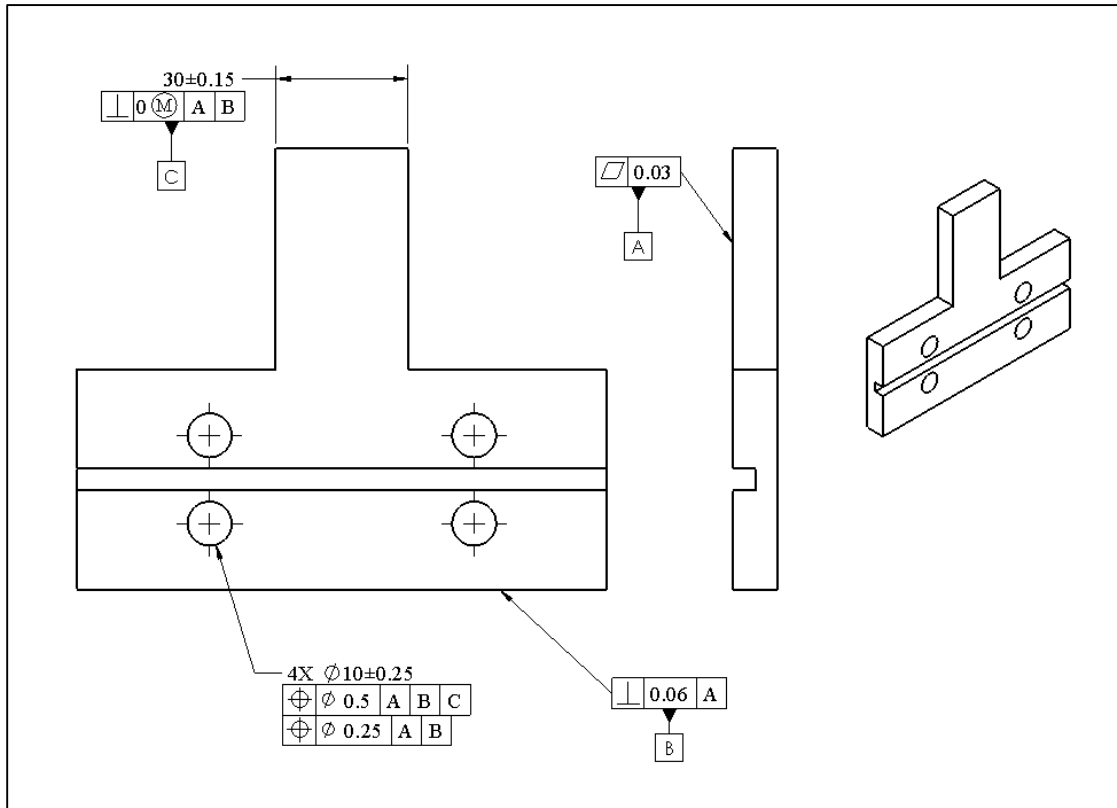
The purpose of applying an  $\textcircled{M}$  modifier to a datum feature is to allow any slack in the datum fit to compensate for inaccuracies of the subject feature pattern during assembly by adjusting the datum fit. In this case, any slack in the fit between the actual datum-C feature and the gage can be used to compensate for the feature pattern shift provided that such an adjustment can be made during assembly.

### **3.5. Composite position tolerance – multiple segments**

In the example previously shown in Figure 3-13, a single position statement controlled the location and orientation of holes within the pattern and with respect to datums A, B, and C. After the part is fixed to a mating part using the stated datum frame, the designer may want to apply additional precision requirements to the same pattern of features. To control the position and orientation of a pattern more precisely another position control statement can be added to the original specification. This additional position tolerance, which has a smaller tolerance value, also controls the relative position of the holes with respect to each other with more precision. This type of position tolerance is called *multiple segment composite position tolerance* and only applies to feature patterns.

Figure 3-23 shows a multi-segment composite position tolerance. Note that there is a separate position tolerance symbol for each statement. The upper segment controls the pattern position with respect to the three datum planes as before. The lower segment

controls the position of the pattern more precisely with respect to two datums, datum-A and datum-B. It also controls the relative location of the features within the pattern with more accuracy.



**Figure 3-23. The multiple segment composite position tolerance statement**

Figure 3-24 shows the gage for the composite tolerance. The gage now includes the 0.25 mm tolerance zone pattern (shown in green) that is not centered with respect to the rail (datum-C) and therefore is free to slide while maintaining its basic distance to datum-B.

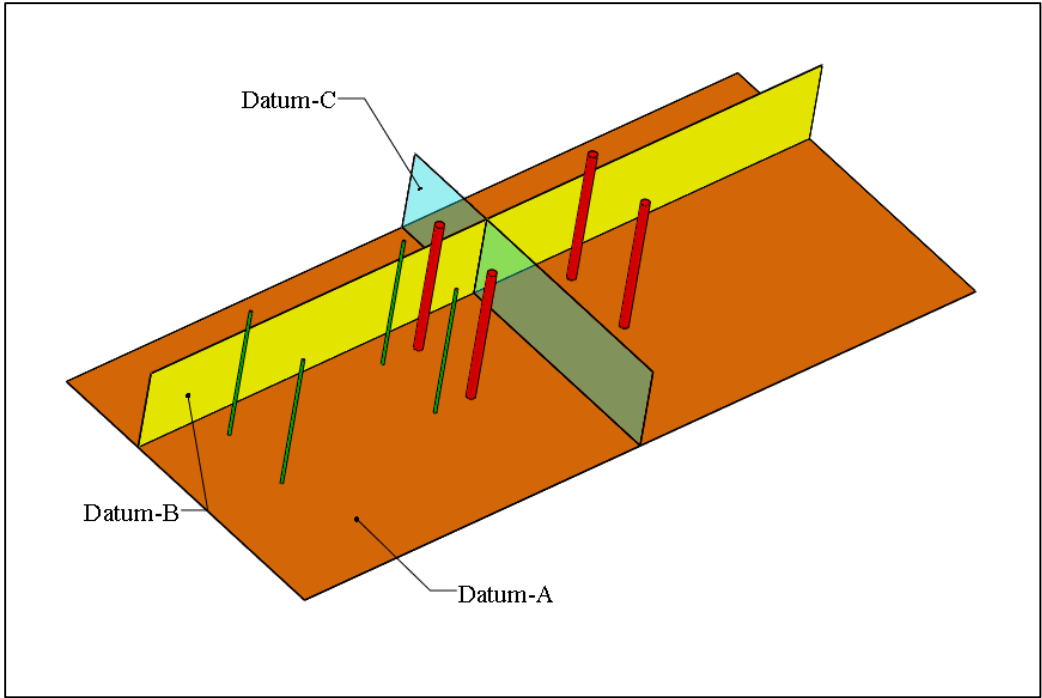


Figure 3-24. The theoretical gage for multiple segment composite position tolerance statement

Figure 3-25 shows the gage for the lower statement. The designer controls the pattern location more closely with respect to datum-A and datum-B without needing the additional level of precision with respect to datum-C. The circles represent the tolerance zones. The arrows show that the tolerance zones can translate as a whole to the right or left (parallel to datum-B) but not up and down (toward datum-B).

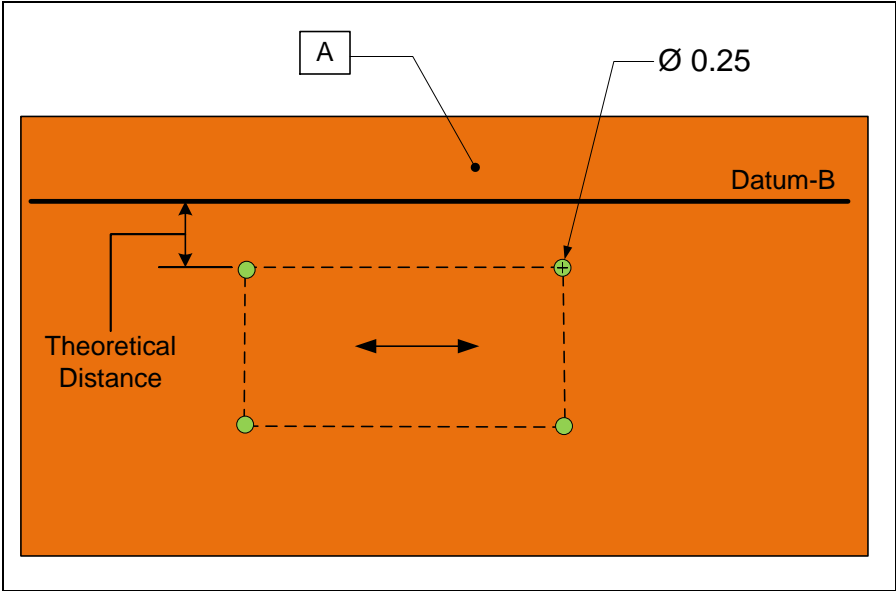


Figure 3-25. The theoretical gage for inspecting the pattern position with respect to datum-A and datum-B

If the tolerance values are  $\textcircled{M}$  modified, the tolerance zones will become acceptance bars of size 9.5 mm for the upper position statement. The specification then controls the combined effect of size and position deviation. For an  $\textcircled{M}$  modified lower specification, the 0.25 mm tolerance zones become 9.75 mm acceptance bars.

If the two statements with the composite format are applied independently as two unconnected statements, then each one would have resulted in a separate gage. The difference is that in the composite format all statements use the same datum alignment with the simulators. This becomes important when one or more of datum features is called out at MMB which allows multiple possible alignments to the datum features during inspection. In practice, the idea is that once a part is placed into an assembly using a particular alignment with the datum features, that alignment cannot be changed when checking the lower statement.

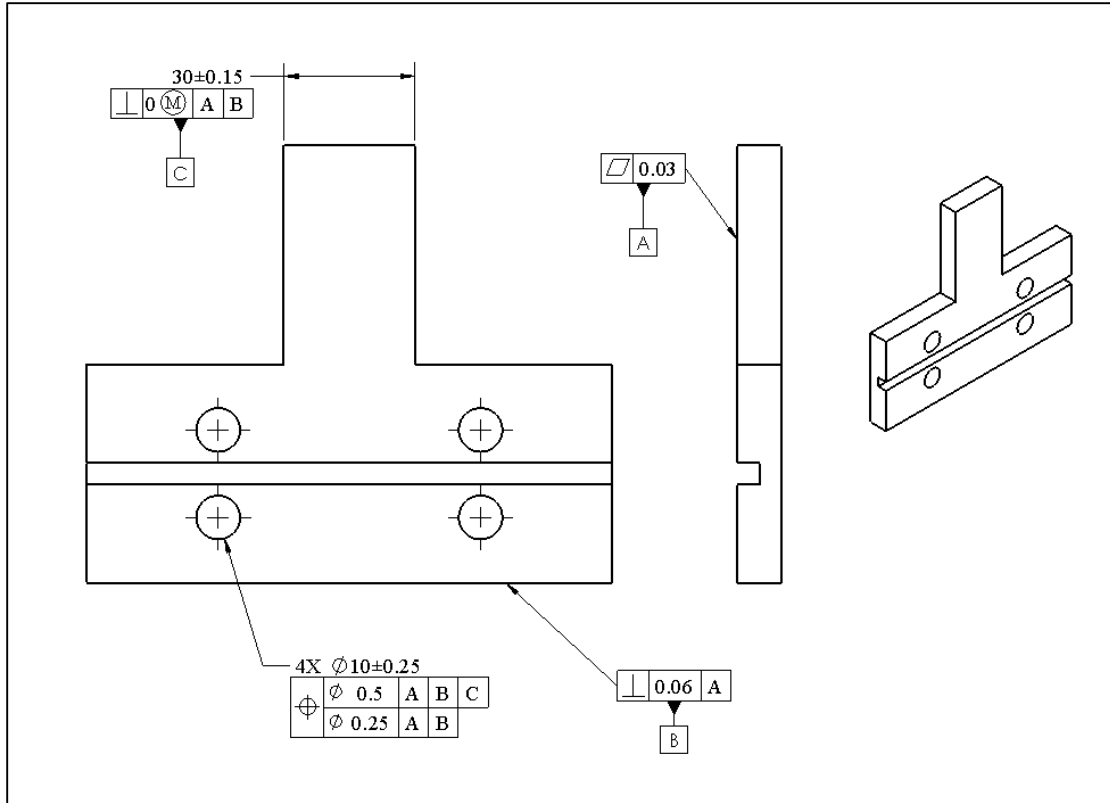
A theoretical inspector first aligns the datum frame with the part datum features and then checks the red tolerance zones associated with the upper tolerance segment. If the pattern passes this stage, the inspector discards the red tolerance zones and slides in the green lower segment tolerance zones to check the lower segment.

Note that in order for the two attached position tolerance statements to be considered a composite tolerance, the datum frame must be repeated exactly in the lower segment, including its order, but usually with fewer datum references. If the datum frame does not repeat exactly in the lower segment, the two statements are interpreted as two independent position tolerance statements.

If the designer intends to make the pattern position even more precise in terms of being square to datum-A and also for the relative positions within the pattern, a third statement can be added to the composite position statement using only datum-A reference. This leads to a gage with a third pattern of tolerance zones with even smaller tolerance zone cylinders. Three-segment composite tolerance statements, however, are not common.

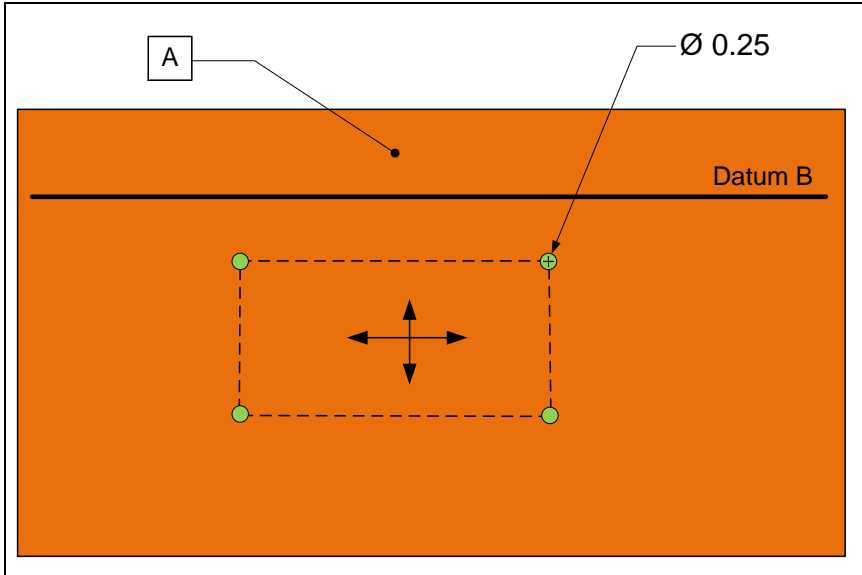
### **3.6. Composite position tolerance – single segment**

A composite position tolerance can be specified in which a single position tolerance symbol is shared by multiple statements. This is called a *single-segment composite position tolerance* format. An example is shown in Figure 3-26.



**Figure 3-26. A single-segment composite position tolerance statement**

In a single-segment position tolerance format, the upper statement is interpreted as in the multi-segment format. The upper statement locates the pattern with respect to the datum features as before. The lower segment, on the other hand, only controls the orientation of the pattern with respect to the specified datum frame as well as the relative location of the feature pattern members. Figure 3-27 shows the tolerance zones resulting from the lower statement of the single-segment tolerance specification. The hole pattern need not be located to datum-B anymore as long as it remains parallel to datum-B. The upper segment still controls how far the pattern can translate toward or away from datum-B.



**Figure 3-27. The theoretical gage for inspecting the pattern position with respect to datum-A and datum-B in a single-segment specification**

For example, the lower segment in Figure 3-26 controls the orientation of the pattern more precisely with respect to datum-A and datum-B. The lower statement also controls the relative location of the pattern features with more accuracy relative to one another. The result of the composite statement is that the pattern is allowed to translate toward or away from datum-B more but it is not allowed to rotate as much. The theoretical gage for this statement is identical to the one for multiple-segment position tolerance format except that the tolerance zone associated with the lower segment is not located and is free to translate away or toward datum-B.

In order for the two position tolerance statements to be considered a composite tolerance, the datum frame must be repeated exactly in the lower segment, including its order and modifiers. If a designer intends to make the relative locations within the pattern even more precise and more perpendicular to datum-A, a third statement can be added to the composite position statement using only datum-A reference. This leads to a gage with a third pattern of tolerance zones having smaller size tolerance cylinders.

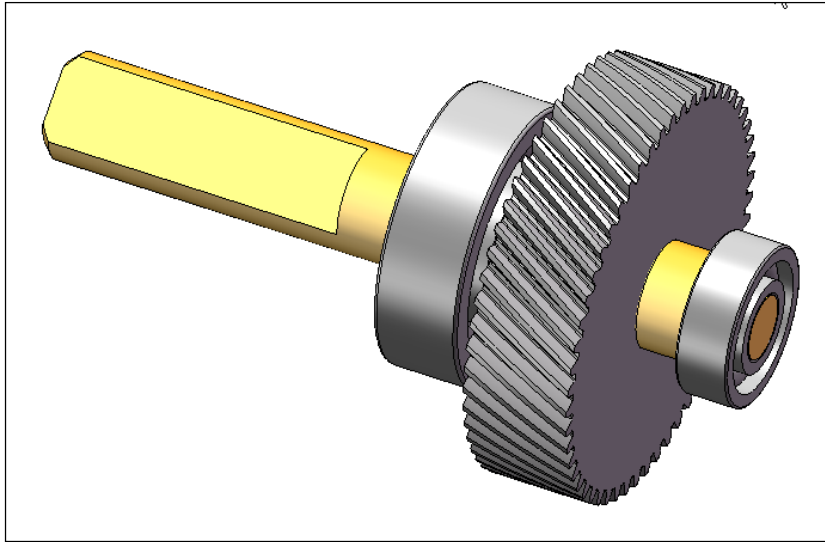
### 3.7. Runout tolerances

#### Circular Runout



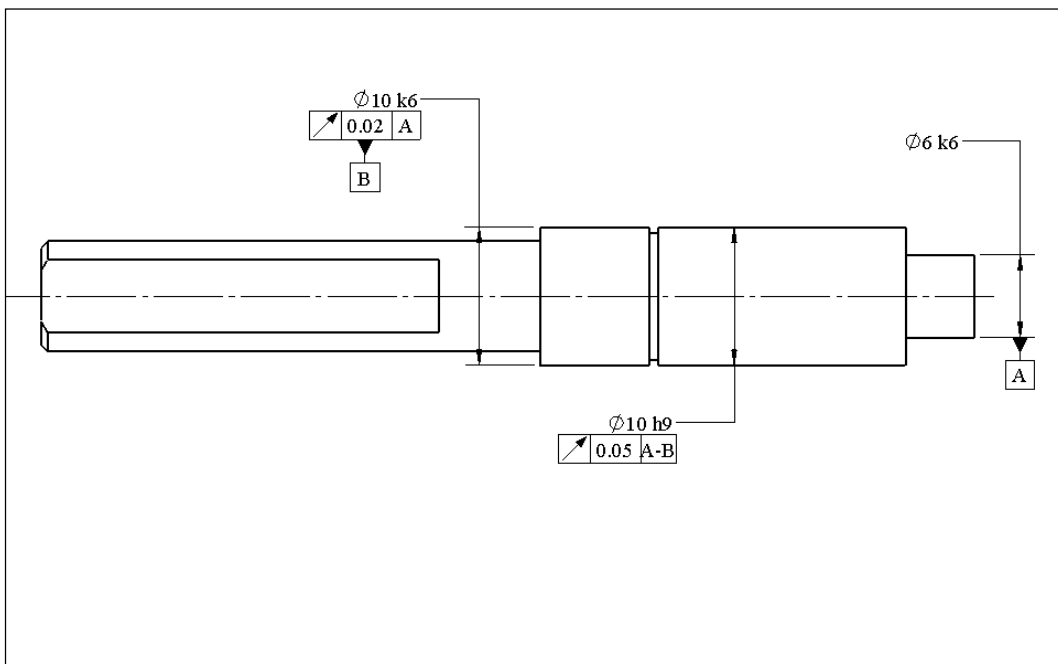
Circular runout requires feature cross-sections to be circular in form and concentric to the axis of a feature selected as datum, to within the specified tolerance value. Circular runout is primarily used to control the coaxiality of shaft cross-sections relative to an axis of rotation. Figure 3-28 shows the shaft assembly of a gearbox. In this application, it is important for the gear's fitting surface to be coaxial to the axis of rotation defined by the

two bearings. Otherwise, the gear teeth will wobble radially in and out shortening the life of the gear.



**Figure 3-28.** A rotating part that requires coaxiality of its features with respect to the axis of rotation defined by the bearings

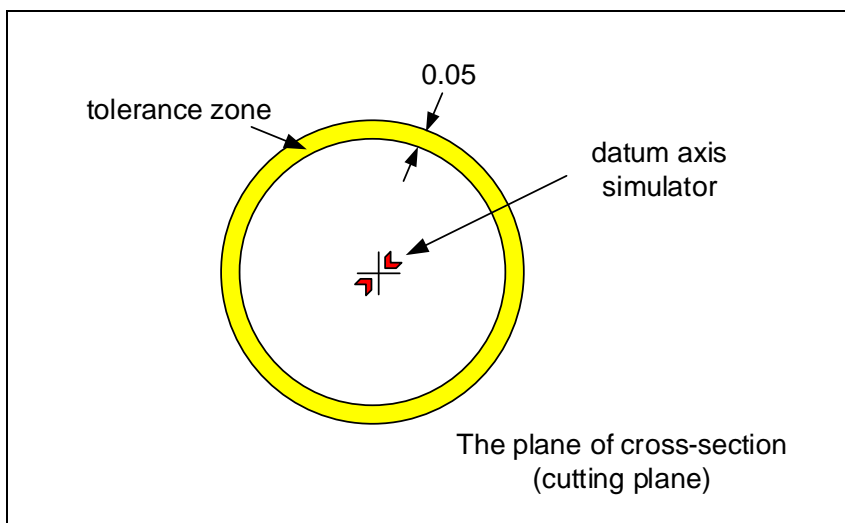
Figure 3-29 shows how this type of tolerance control can be specified using circular runout specification. The 10k6 and 10h9 codes define the feature size limits. The application of these size codes will be covered in Chapter-6.



**Figure 3-29.** An example of coaxiality control through circular runout statement

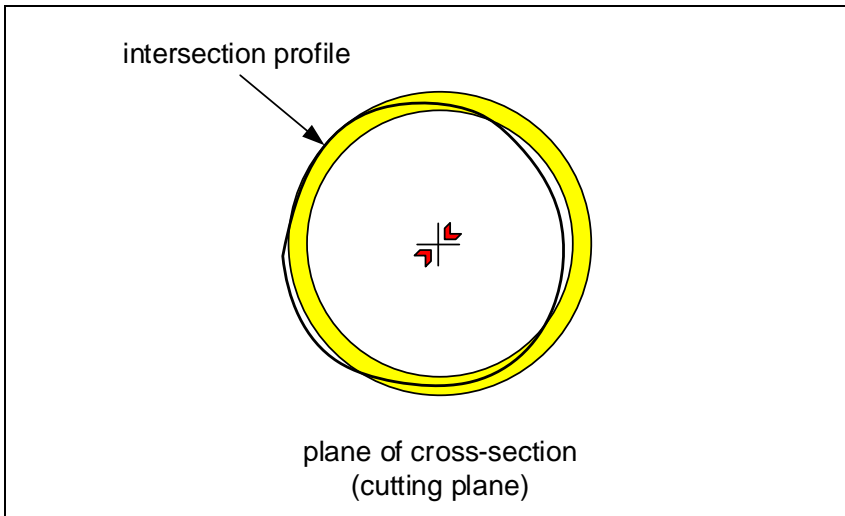
Datum-A defines the axis of the smaller bearing fit cylinder. The larger bearing fit cylinder is controlled to be coaxial to datum-A with high precision using circular runout specification. The axis of the larger bearing cylinder is identified as datum-B. The gear's fit surface is specified to be coaxial to an axis defined by the two bearing axes simultaneously. Other than lack of coaxiality, lack of circularity also influences circular runout.

The primary datum in circular runout specification is always an axis obtained by a collapsing (or expanding) datum simulator. The tolerance zone is the 2D zone defined by a pair of concentric circles with a radial thickness equal to the specified tolerance as shown in Figure 3-30. The tolerance zone is similar to circularity zone but there is an added datum axis in the center of the circles.



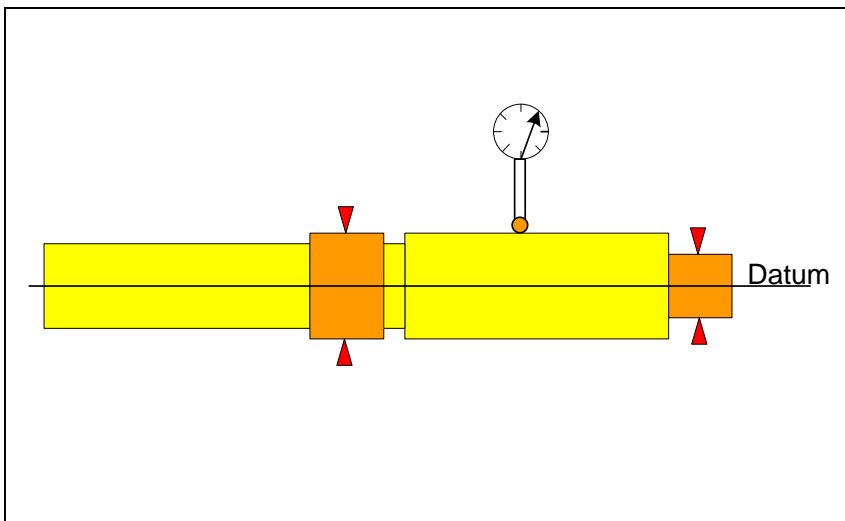
**Figure 3-30. Theoretical gage for circular runout consists of two concentric circles and an axis on a planar surface**

In the theoretical inspection, the two collapsing holes for the datum features simultaneously grip the part. Then the plane of the cross-section cuts the part determining the intersection profile of the gear surface with the cutting plane. This is shown in Figure 3-31.



**Figure 3-31. Theoretical gage for circular runout and the cross-section of the subject feature**

In this case, the cross-section is circular enough but it is off center with respect to the datum axis. Circular runout specification is easy to verify using a simple inspection set up such the one shown in Figure 3-32.

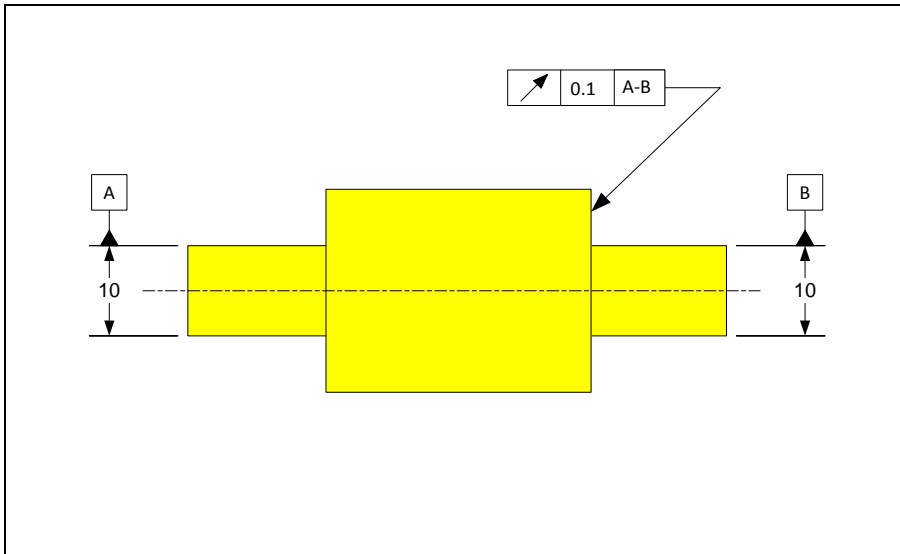


**Figure 3-32. The most common method of verification of circular runout statement**

To do the physical inspection, the part ends are fixed in rotating chucks (collapsing cylinders). These chucks locate the center of rotation and establish the datum axis. The chucks are simultaneously tightened so neither of the datum cylinders is favored. The plane of the dial indicator simulates the cutting plane. The dial stem is perpendicular to the axis of the chuck and radially aligned with it. The part is then rotated with the dial indicator set up to measure radial deviations. As the part rotates, the full movement of the indicator (FIM), or the range of the dial travel, measures the runout of the cross-section relative to the axis of rotation. If this measured runout is smaller than the

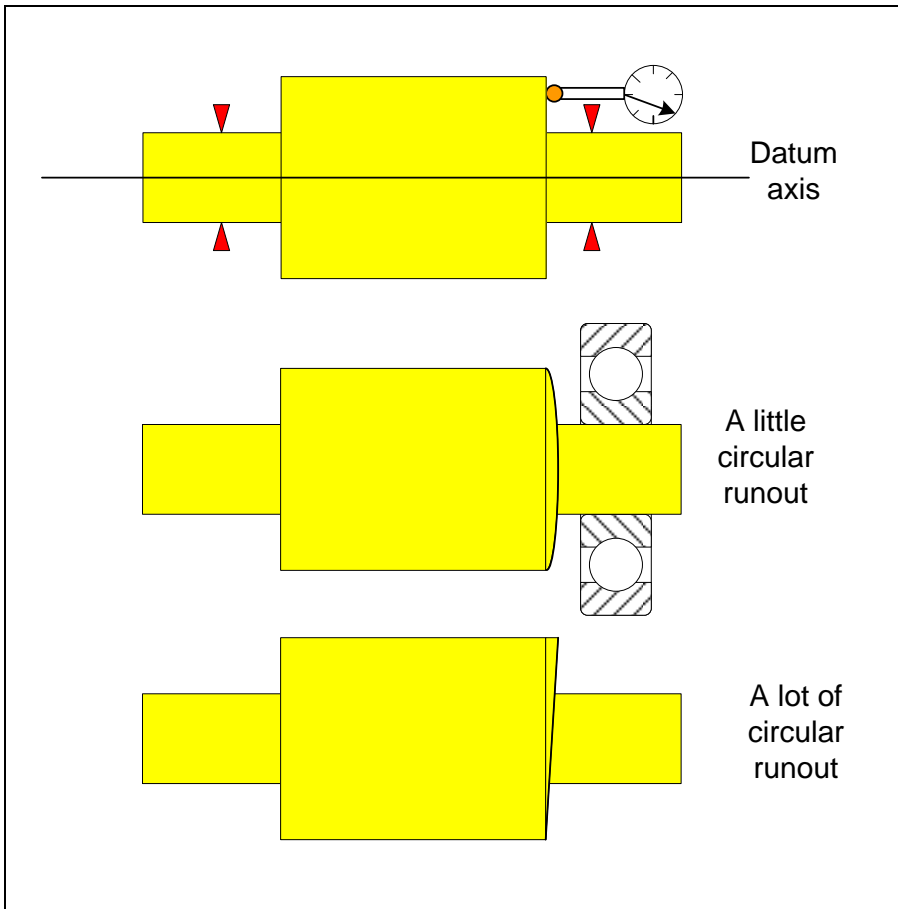
tolerance value, the measured cross-section is within tolerance. For checking another cross-section, the dial is moved to that cross-section and the process is repeated. Unless otherwise indicated on the drawing as a note adjacent to the runout specification, the runout applies to all cross-sections of the feature.

Circular runout can also be used to control the perpendicularity of shaft shoulders with respect to the axis of rotation. This is the specification of choice when controlling shaft shoulders that support bearings, gears, or other shaft components. Figure 3-33 shows an example.



**Figure 3-33. An example of shoulder perpendicularity control through circular runout statement**

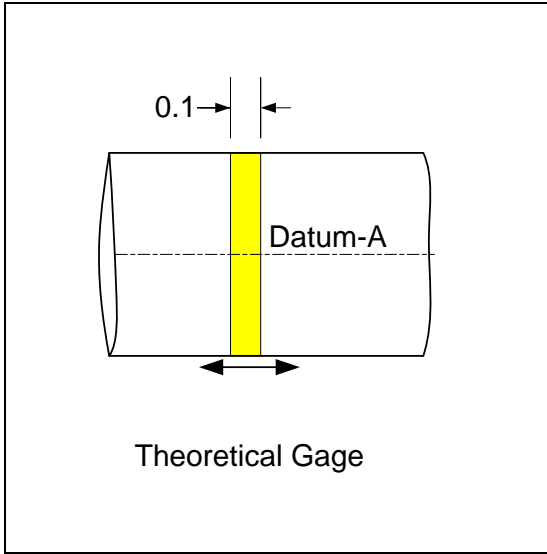
Circular runout specification applied to planar surfaces is also easy to verify using a simple inspection set up such as the one shown in the top of Figure 3-34.



**Figure 3-34. The most common method of simulating the theoretical gage for the verification of circular runout statement**

Unless otherwise specified, the specification applies independently to all circles on the subject plane. That means the dial indicator test must be applied at various circle sizes. When the surface bulges out or in, as shown in the part in the middle of the figure, no runout would register on the dial. The function of a bearing or a similar component that is fitted to a rotating shaft is not adversely affected by this kind of surface. The part in the bottom of the figure is unacceptable and, when tested, shows a lot of runout. This kind of surface forces the bearing or the component to rotate relative to the axis of rotation.

If you are curious to know, the theoretical gage for the specification in Figure 3-33 is a strip of cylindrical surface and a datum axis as shown in Figure 3-35. The axial length of the strip is the tolerance value. The strip is free to translate along the datum-A axis. The diameter of the cylinder corresponds to the location along the shoulder where the runout is checked.



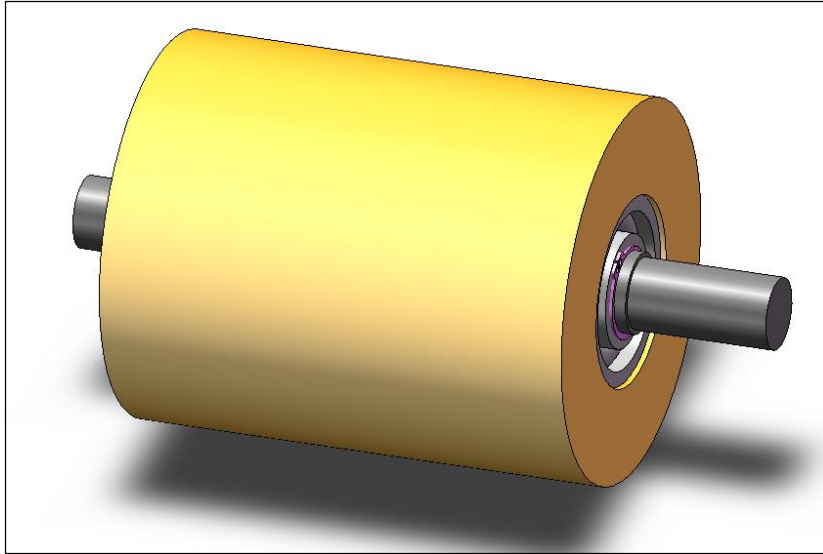
**Figure 3-35. The theoretical gage for circular runout applied to a planar surface is a cylindrical surface**

To check the part against this gage, the axis labeled datum-A is aligned with the actual A-B datum of the part. Then, the cylindrical tolerance zone surface cuts the subject plane and creates a curve of intersection. That curve of intersection must then fit inside the tolerance zone of the theoretical gage.

### **Total runout**

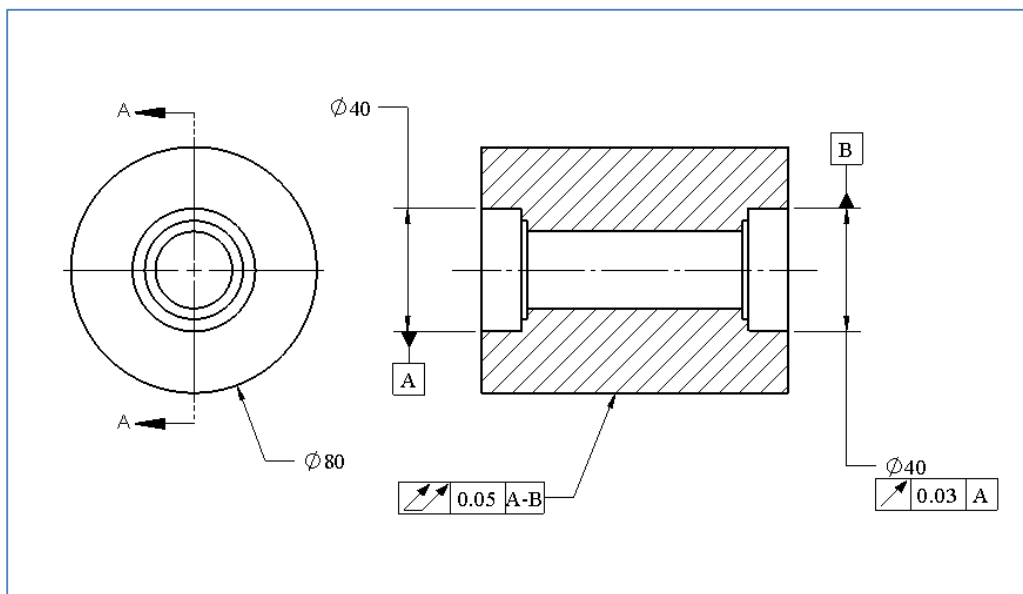


Total runout requires features to be cylindrical in form and coaxial with respect to the axis of a feature selected as datum to within a specified tolerance value. Figure 3-36 shows the roller assembly of a machine. For functional reasons it is important to have a precisely uniform distance between this roller and an opposing roller or plate as the roller turns. This type of precision requires total runout specification which controls the combined tolerances of cylindricity and coaxiality.



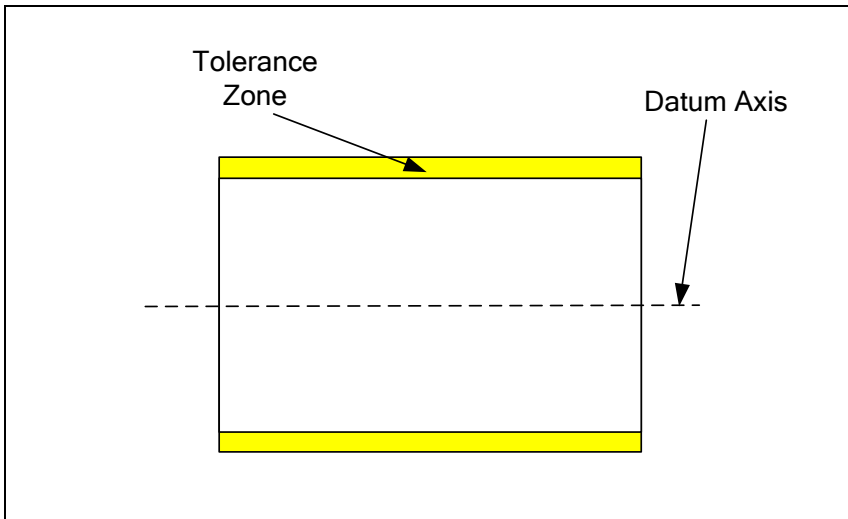
**Figure 3-36.** The roller surface in this assembly should be coaxial with the axis of rotation

Figure 3-37 shows the total runout specification for the outer cylinder.



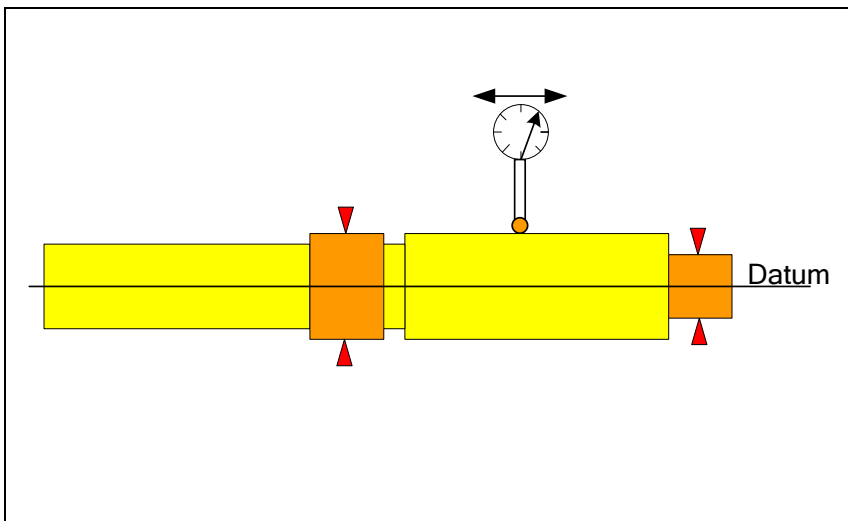
**Figure 3-37.** An example of total runout tolerance statement

Datum-A is a high precision bearing fit hole. Datum-B is a bearing hole functionally identical to datum-A but on the other side of the roller. The theoretical gage for total runout is similar to the circular runout except that the gage is three-dimensional. Figure 3-38 shows the theoretical gage for total runout.



**Figure 3-38. Theoretical gage for total runout consists of two concentric cylinders and an axis**

During gaging, the datum axis of the gage is aligned with the axis of the datum feature using collapsing cylinders. The cylindrical subject feature is then checked against the tolerance zone. Total runout specification is also easy to verify using the simple inspection set up used for circular runout as shown in Figure 3-39.



**Figure 3-39. The most common method of simulating the theoretical gage for the verification of a total runout statement**

Compared to circular runout, the only difference is that once the dial is set in the beginning, the full indicator movement (FIM) includes the range of movement as the indicator is moved to other cross-sections. The total runout is measured as the FIM of the dial. Total runout applied to a shaft shoulder is identical to perpendicularity tolerance with respect to the datum axis.

### 3.8. Profile tolerances

A surface profile is the general term used to refer to any type of surface or any selected group of surfaces. A profile feature's size, form, orientation, and location can be controlled using one or more profile statements. The surface profile statement is a good replacement for the traditional  $\pm$  tolerances for features not involved with fit. The  $\pm$  tolerances should still be used for size tolerances with features-of-size in fit applications.

#### Profile of a surface tolerance $\bigcirc$

Profile of a surface tolerance is the general-purpose surface feature control specification of the GDT standard. Profile tolerance can be applied to surface features of any shape including any grouping of features. In fact, the entire outer skin of a part is an important profile feature that is commonly controlled in default tolerancing.

The profile of a surface tolerance controls one or more surface features to remain within a thin envelope around their basic or theoretical shape. This thin envelope is the tolerance zone geometry. The profile tolerance is often used with a datum frame to control both the size and the location of a profile. Figure 3-40 shows two examples. The circle attached to the arrow is the "All Around" symbol indicating that the tolerance statement applies to all the surfaces making up the inner profile, or the outer profile of the turning support part. The dimensions are theoretical dimensions and are shown here to explain the gage geometry.

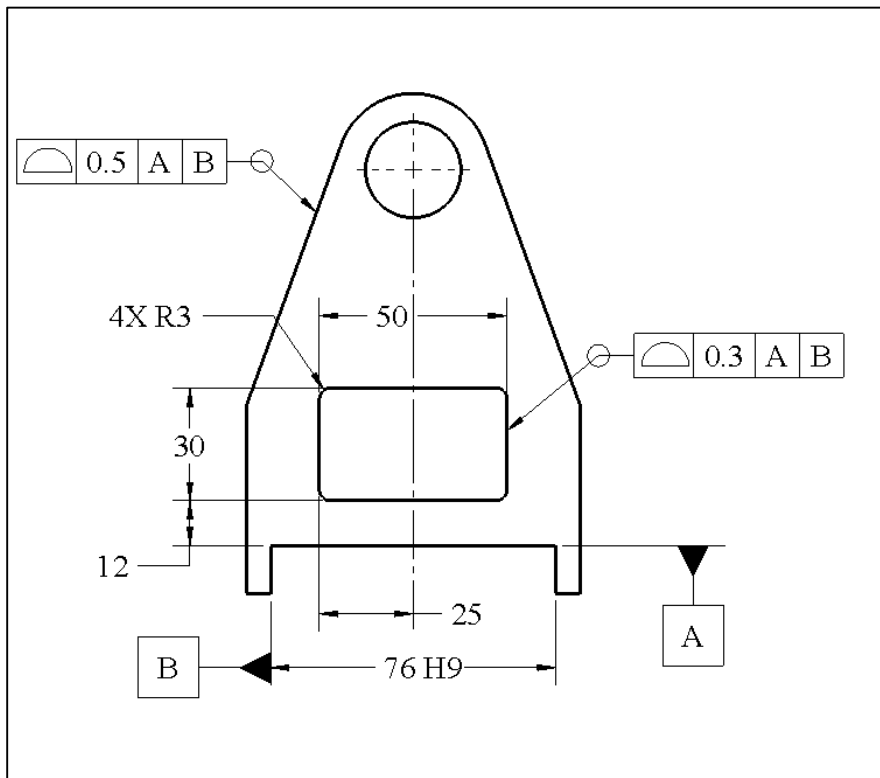
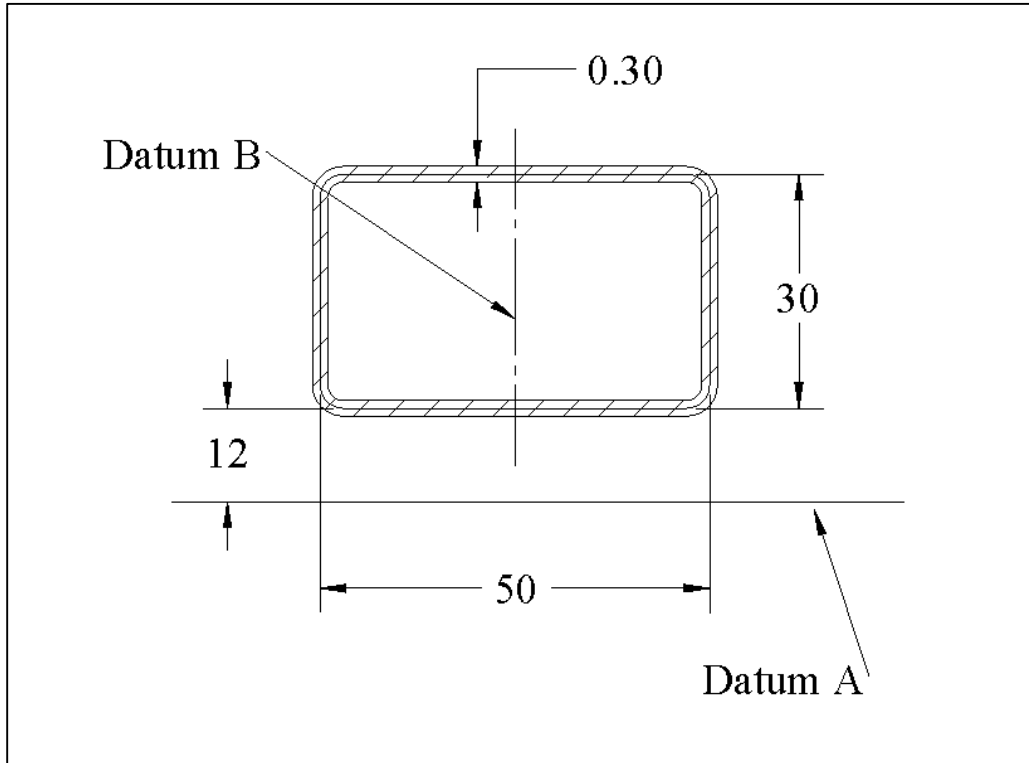


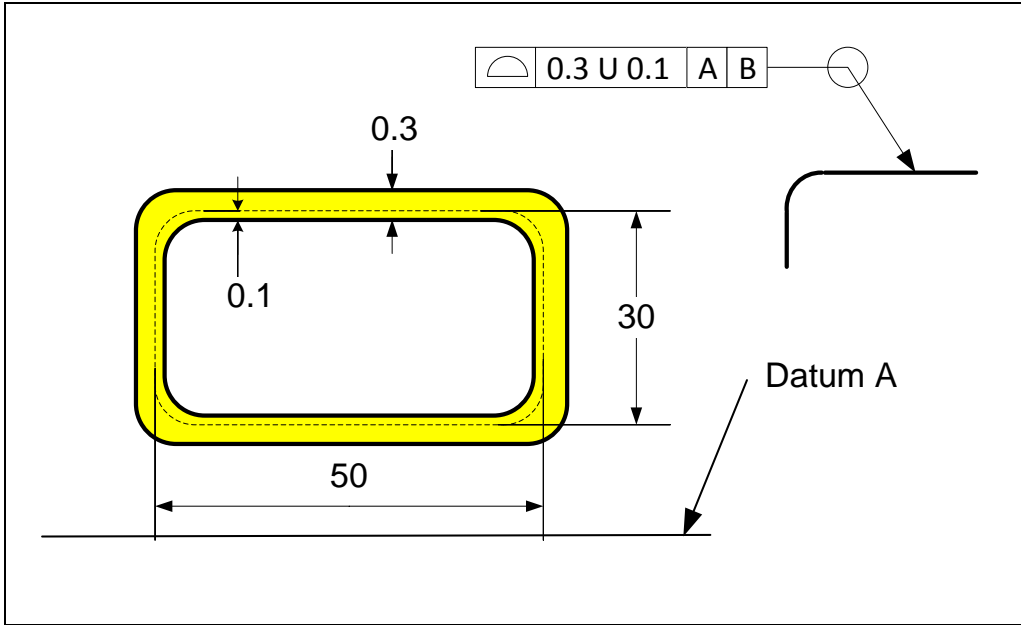
Figure 3-40. Examples of profile of surface tolerance specifications

The tolerance statement controls the size of the entire shape. The feature is also located and oriented relative to the bottom surface (datum-A) and it is centered relative to the slot center plane (datum-B). The theoretical gage for this specification is shown in Figure 3-41. The 0.3 mm tolerance zone has a depth larger than the thickness of the part.



**Figure 3-41. Theoretical gage for profile statement**

The profile tolerance can also be specified to be unequally divided about the theoretical profile geometry using a simple notation. Figure 3-42 shows an example. If the profile tolerance is to be divided such that 0.1 mm is allocated in the direction of adding material to the theoretical shape, the tolerance value of 0.3 U 0.1 should be specified. The first number is the total thickness of the tolerance zone and the second number is the thickness of the portion that adds material to the part. The dashed line in the figure represents the theoretical profile shape.



**Figure 3-42. An example of unequally divided profile tolerance specification and the resulting tolerance zone**

The specification 0.3 U 0.3 defines the entire tolerance zone in the direction that adds material to the part. The specification 0.3 U 0 defines the entire tolerance zone in the direction that removes material from the part.

Composite profile statements can be used to control various geometric aspects of a profile with finer levels of precision. Composite profile tolerances use the single segment format in which one profile tolerance symbol is shared by multiple statements. Each statement must use a progressively smaller tolerance value. For example, consider the specification in Figure 3-43.

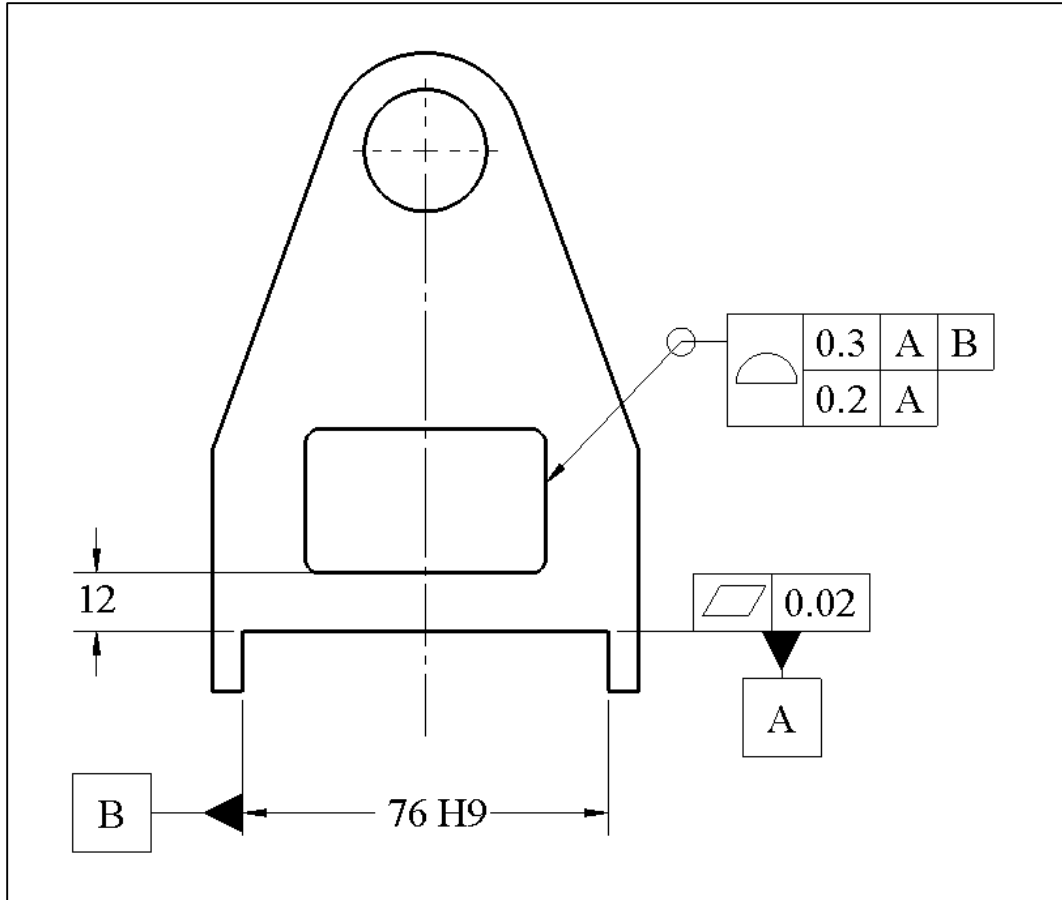


Figure 3-43. An example of a composite profile tolerance with two statements

The upper profile statement controls the size, form, orientation, and location of the feature with an accuracy of 0.3 mm relative to datum-A and datum-B. The lower statement controls the size and orientation relative to datum-A with the finer accuracy of 0.2 mm.

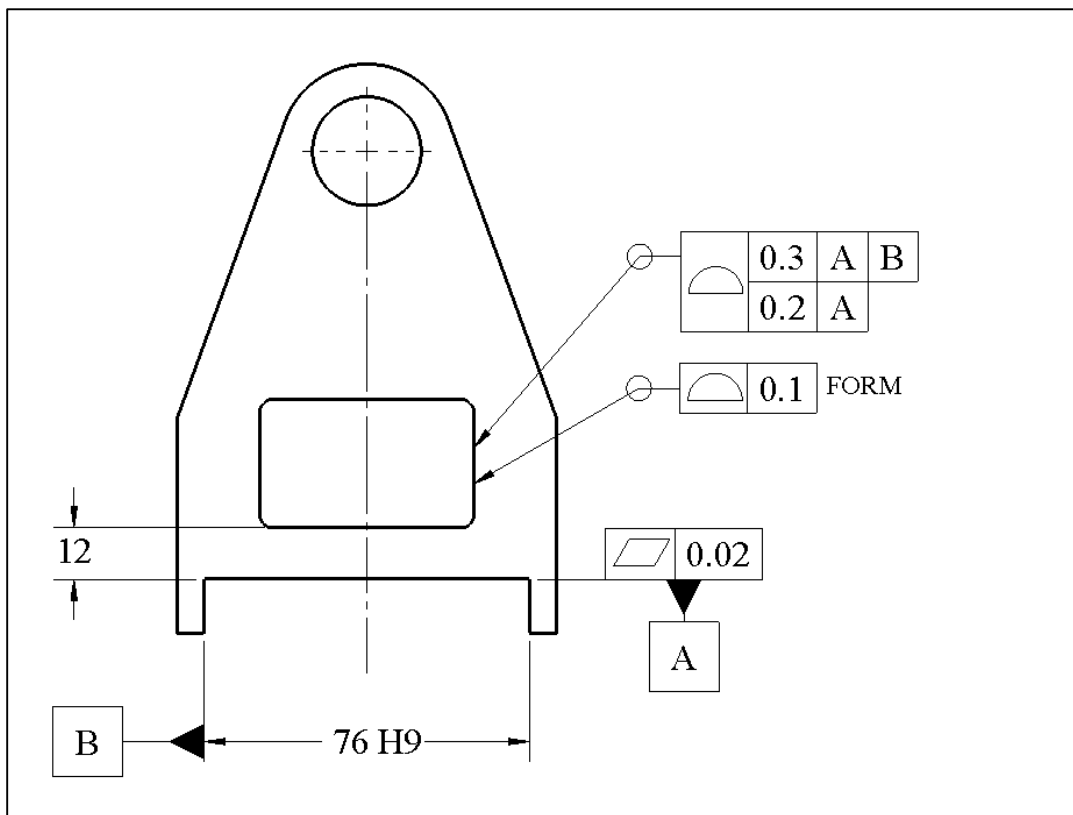
The theoretical gage for this statement uses the same datum simulators for both the upper and the lower statements. Once the upper statement is verified, the 0.3 mm tolerance zone is removed and a new 0.2 mm tolerance zone is brought in without changing the part alignment to datum-A simulator. The new tolerance zone is parallel to the datum-A surface. If it is important to additionally control the size of the profile with finer accuracy a third row of specification can be added with a smaller tolerance value and without any datum reference.

All profile tolerances control the profile size by creating tolerance zones that are equally or unequally disposed about the theoretical profile. The only exception, according to the GDT Standard, is with the control of conical surfaces in which dimension limits can be used to control the cone size and a profile tolerance can be used to control the cone form. It is important, however, to be able to control profile form, orientation, or location separately from profile size for all features. To do this, a word or a symbol can be placed

next to the profile tolerance statement and explained as a note. In this book the word FORM is used for this purpose. The following note should then be added in the drawing notes section to explain the meaning of the tolerance statement:

*FORM: The actual profile must lie within a tolerance zone defined by a pair of profile surface offsets with a separation equal to the tolerance value*

If the profile tolerance is used with an orienting datum reference the FORM designation would control the form and the orientation of the profile. If the profile tolerance is used with an orienting and a locating datum reference the FORM designation would control the form, the orientation, and the location of the profile. Figure 3-44 shows a specification example. The form control statement can also be added as a third statement in the composite statement format.

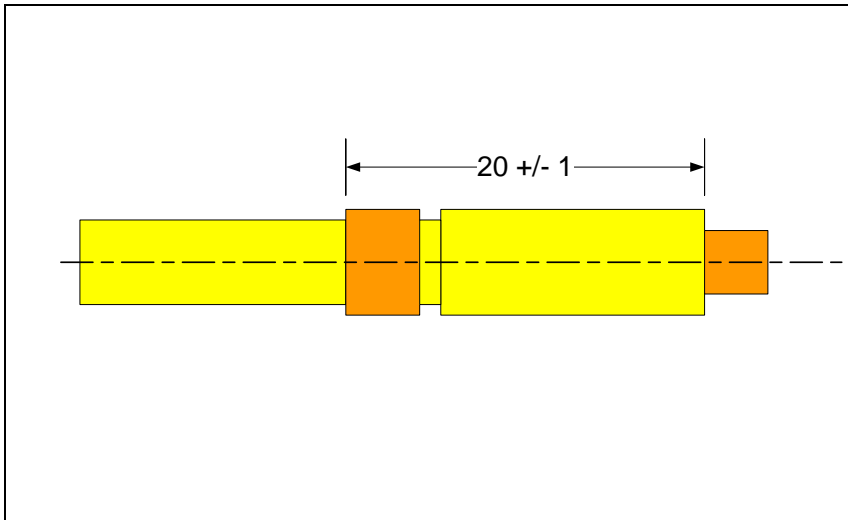


**Figure 3-44. Adding a statement for profile form control**

For profile form control shown in the figure, the tolerance zone has a thickness of 0.1 mm but the zone size can expand or contract within the limits of size similar to other form control specifications such as cylindricity. If the form control (i.e. the text FORM) is applied to the lower statement with 0.2 mm tolerance value then the profile size would be dictated by the 0.3 mm zone while the profile combined orientation and form remain within the smaller 0.2 mm zone.

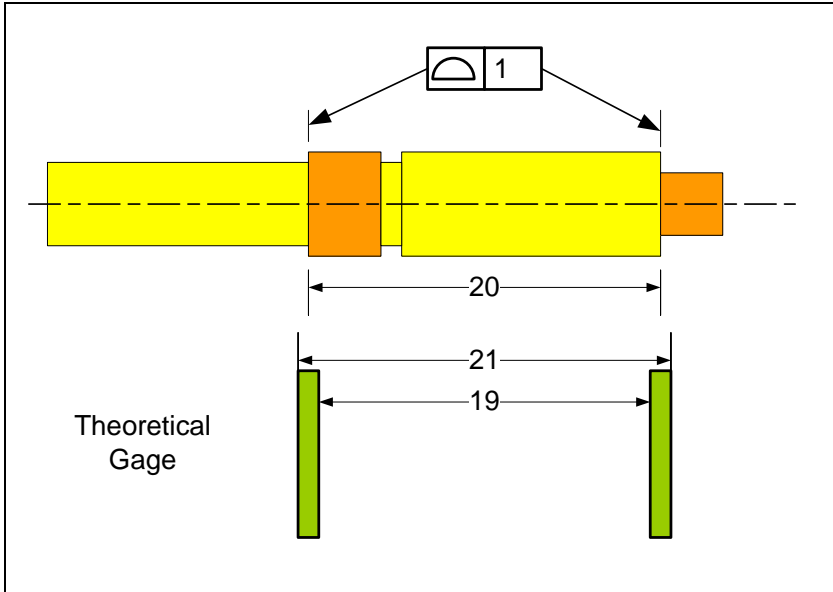
### 3.9. Profile tolerances in place of $\pm$ tolerances

When the distance between two parallel planes is to be controlled the use of profile of surface tolerance is preferred to the use of  $\pm$  limits on dimensions unless the feature is a fit feature (it has opposing planes and fits a mating feature). Consider the shaft in Figure 3-45. The 20 mm distance between two of the shaft shoulders needs to be controlled. In this specification, the indicated feature dimension is to be between 19 and 21 mm.



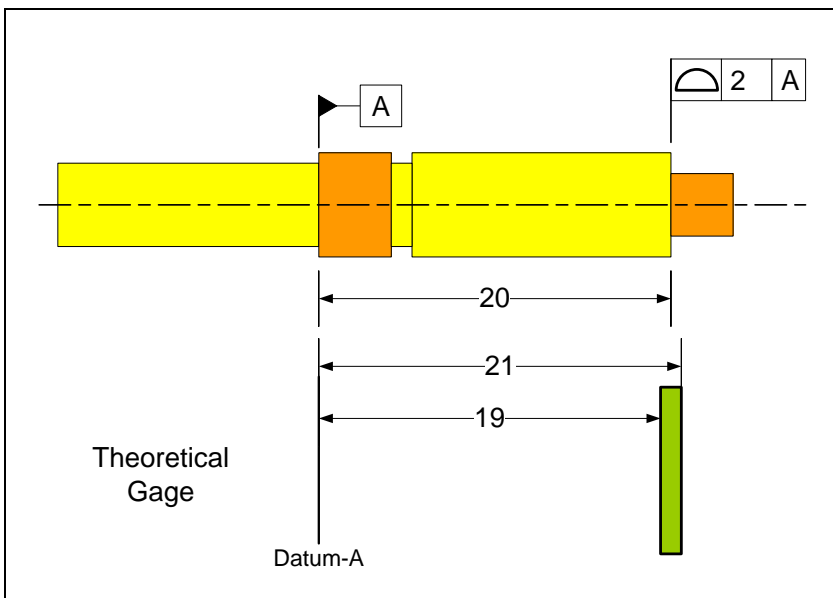
**Figure 3-45.** The distance between the two shoulders is controlled using dimension limits

The meaning of the dimension limits, however, is not clear when the two faces do not have perfect forms, or are not perfectly parallel. What is “obvious” to one person is not so obvious to another. Figure 3-46 shows the alternative profile tolerance statement that is not vague. The figure also shows the theoretical gage resulting from this statement that allows the two planes be as far as 21 mm or as close as 19 mm similar to the dimension limits. The profile tolerance alternative is preferred because its interpretation in terms of an acceptance gage is well defined.



**Figure 3-46. Control of distance between two planes using profile of surface tolerance statement**

When controlling the distance between two planes using a profile statement, it is preferred to specify an origin of measurement. This is shown on the upper part of Figure 3-47. The theoretical gage for this specification is shown in the lower part of the figure.



**Figure 3-47. Preferred way to control of distance between two planes using profile of surface tolerance statement with specification of origin of measurement**

Figure 3-48 shows a shorthand notation for profile specification that does not explicitly label the datum. The end of the dimension line without an arrow implicitly defines a datum plane. This format of controlling distances is convenient as it does not require explicit labeling of the datum.

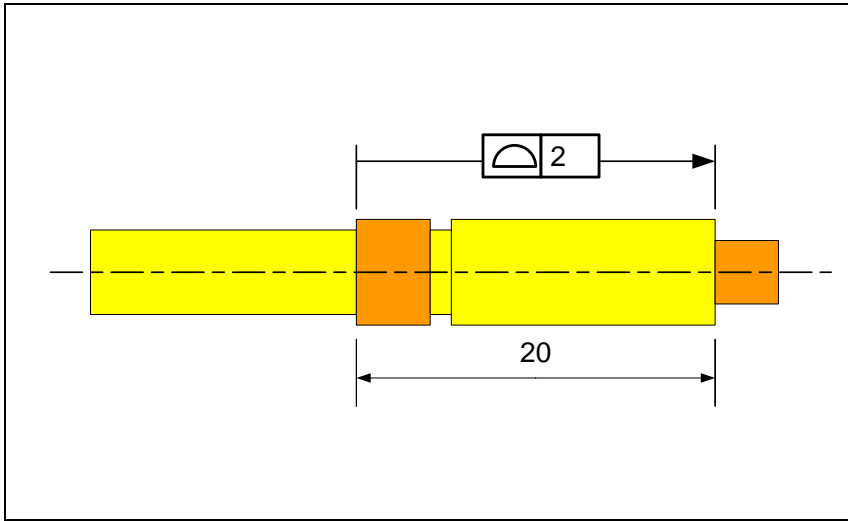
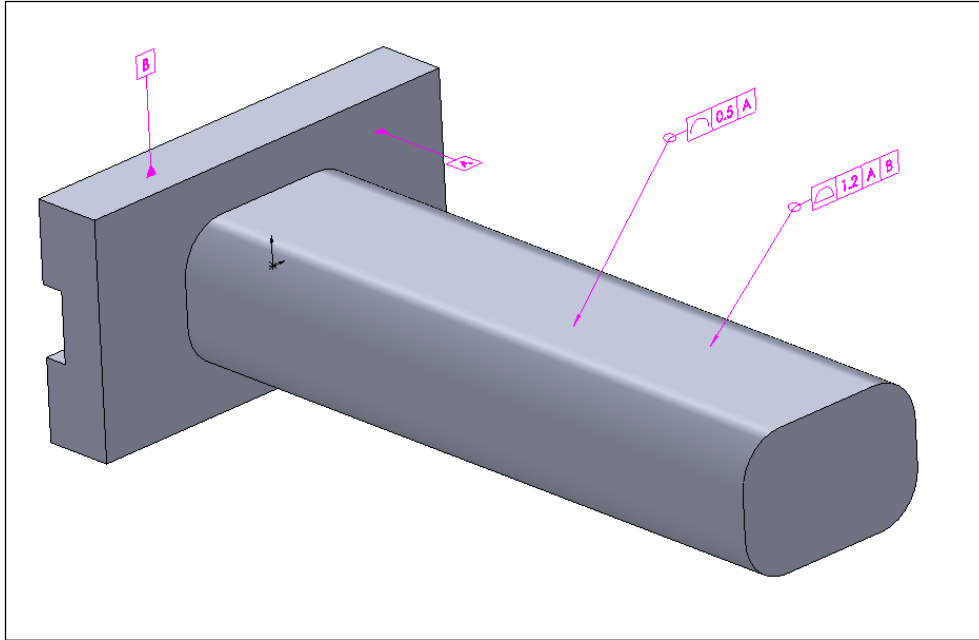


Figure 3-48. Shorthand specification of profile tolerance with implied datum reference

Profile tolerance can also be applied to control a pattern of features similar to feature patterns controlled by position tolerance statements.

### Profile of a line tolerance $\curvearrowright$

Profile of a line tolerance is the general-purpose 2D tolerance control specification of the GDT standard. The profile of a line tolerance can be applied to curve features of any shape that result from the intersection of a surface profile and a cutting plane. Profile of a line tolerance can control the size and location of 2D cross-sections of a feature. This statement is often used to control the size of a feature's cross-sections with finer accuracy after a surface profile tolerance is applied. The theoretical gage for profile of a line statement is a thin envelope around the basic geometric shape of the feature in the plane of cross-sections. Figure 3-49 shows an example of the use of profile of a line tolerance.



**Figure 3-49. An example of the profile of a line statement**

In this example, the designer has used the profile of a surface statement to control the size and location of the entire surface feature with a relatively wide 1.2 mm tolerance value. To control the size of each cross-section with more accuracy, the designer adds a profile of a line tolerance with a tolerance value of 0.5 mm. The datum-A reference requires the cutting planes to be parallel to datum-A. If the datum-A is not mentioned, the cutting planes would be normal to the feature spine. The combined effect of the two profile statements is that the bar cross-sections are more precise in size but the bar can have a larger degree of bend or twist as long as it remains within the wider profile of a surface specification.

### **Exercise Problems**

1. Consider the turning support part shown in Figure 3-50.

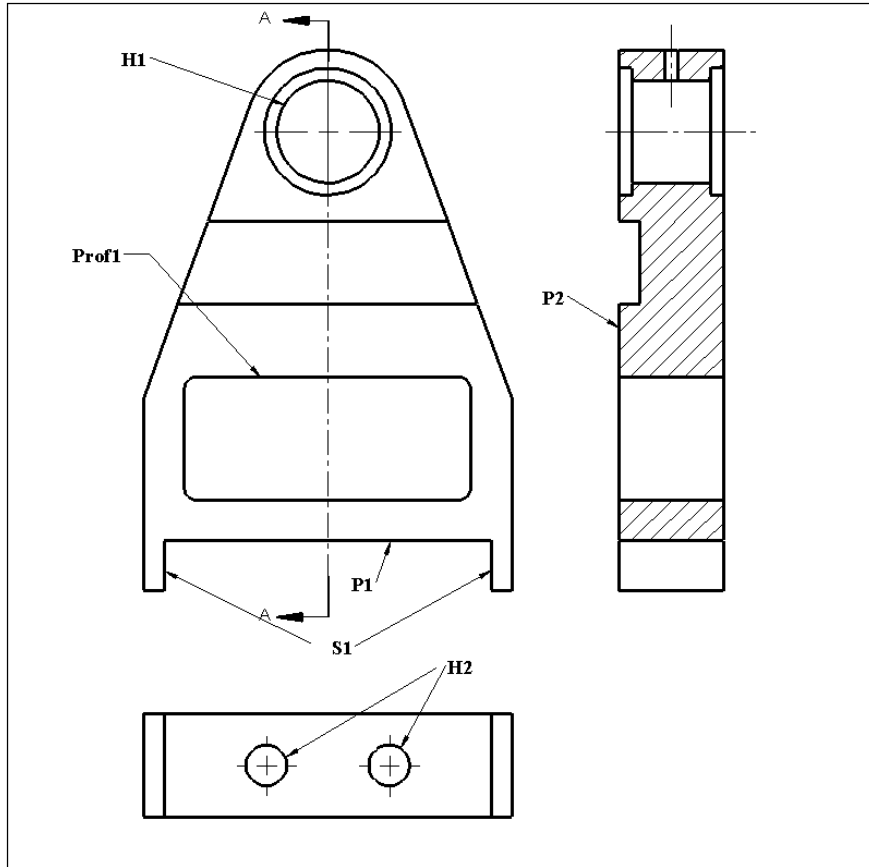


Figure 3-50. Turning support part

Specify the following labels and tolerances.

- Define  $P_1$  as datum-A.
- Define  $S_1$  as datum-B.
- Define  $P_2$  as datum-C.
- Make datum-A feature flat to within 0.02 mm.
- Make datum-B feature perpendicular to datum-A feature to within 0.05 mm.
- Make datum-C feature perpendicular to datum-A and datum-B to within 0.1 mm.
- Specify the size limits of  $H_1$  to be  $20 \pm 0.02$  mm.
- Specify the size limits of  $S_1$  to be  $76.00 - 76.15$  mm.
- Specify the size limits of  $H_2$  to be  $12.00 - 12.25$  mm.
- Specify  $H_1$  to be parallel and located to  $P_1$  and aligned with  $S_1$ . Use a tolerance value of 0.1 mm.
- Control  $H_2$  to be perpendicular to  $P_1$  and aligned to  $S_1$ . Use a tolerance value of 0.75 mm and make the specification  $\textcircled{M}$  modified.
- Control the orientation of  $H_1$  to be more precisely parallel to  $P_1$ . Use a tolerance value of 0.06 mm.

- m. Control the size and location of  $\text{Prof}_1$  to be parallel to and located to  $P_1$  and aligned with  $S_1$ . Use a tolerance value of 1 mm.
  - n. Refine the size and orientation precision of  $\text{Prof}_1$  relative to  $P_1$  using a tolerance value of 0.5 mm.
  - o. Refine the form and orientation precision of  $\text{Prof}_1$  relative to  $P_1$  using a tolerance value of 0.3 mm.
  - p. Refine the form precision of  $\text{Prof}_1$  using a tolerance value of 0.1 mm.
  - q. Specify a plate thickness tolerance of 0.5 mm using short-hand profile tolerance specification using any of the two parallel faces as implicit datum.
2. Consider the part shown in Figure 3-51. For each tolerance statement in the following list, draw the theoretical gage and indicate the gage dimensions.
- a. The position tolerance specification. Create a theoretical gage with two different tolerance zones, one for the upper and one for the lower segments.
  - b. Theoretical gages for part (a) when the  $\textcircled{M}$  modifier is used in the tolerance statements.
  - c. The profile statement for the inner shape.
  - d. The profile statement that controls the plate thickness.

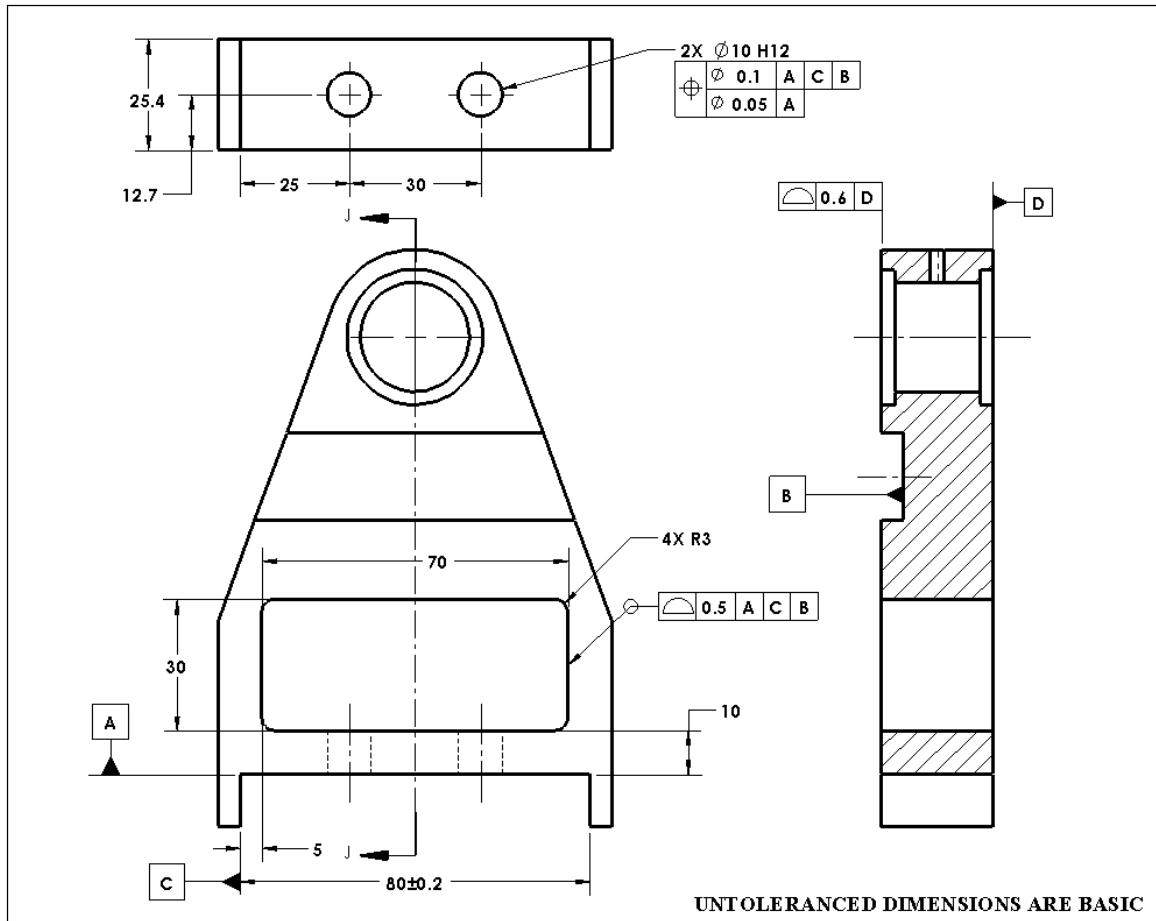
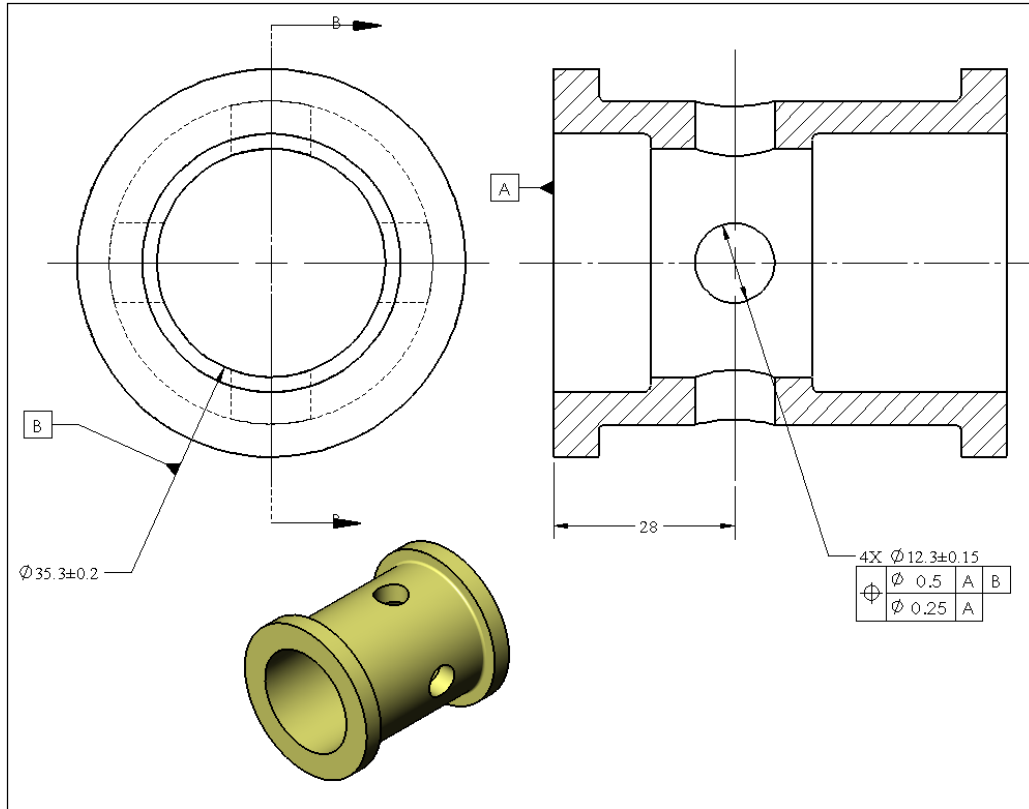


Figure 3-51. Turning support part

3. Consider the part shown in Figure 3-52.
  - a) Draw the theoretical gage for the composite position tolerance.
  - b) Draw the theoretical gage when the  $\textcircled{M}$  modifier is used with the tolerance value.
  - c) Draw the theoretical gage when the  $\textcircled{M}$  modifier is used both with the tolerance value and with datum-B.
  - d) Create the CAD model of a physical gage for part c).



**Figure 3-52. A part with a pattern of radial holes**

4. Consider the part shown in Figure 3-53.
  - a) Draw the theoretical gage for the composite position tolerance.
  - b) Draw the theoretical gage when the  $\textcircled{M}$  modifier is used with the tolerance value.
  - c) Draw the theoretical gage when the  $\textcircled{M}$  modifier is used with the tolerance value, datum-B, and datum-C.
  - d) Create the CAD model of a physical gage for part c).

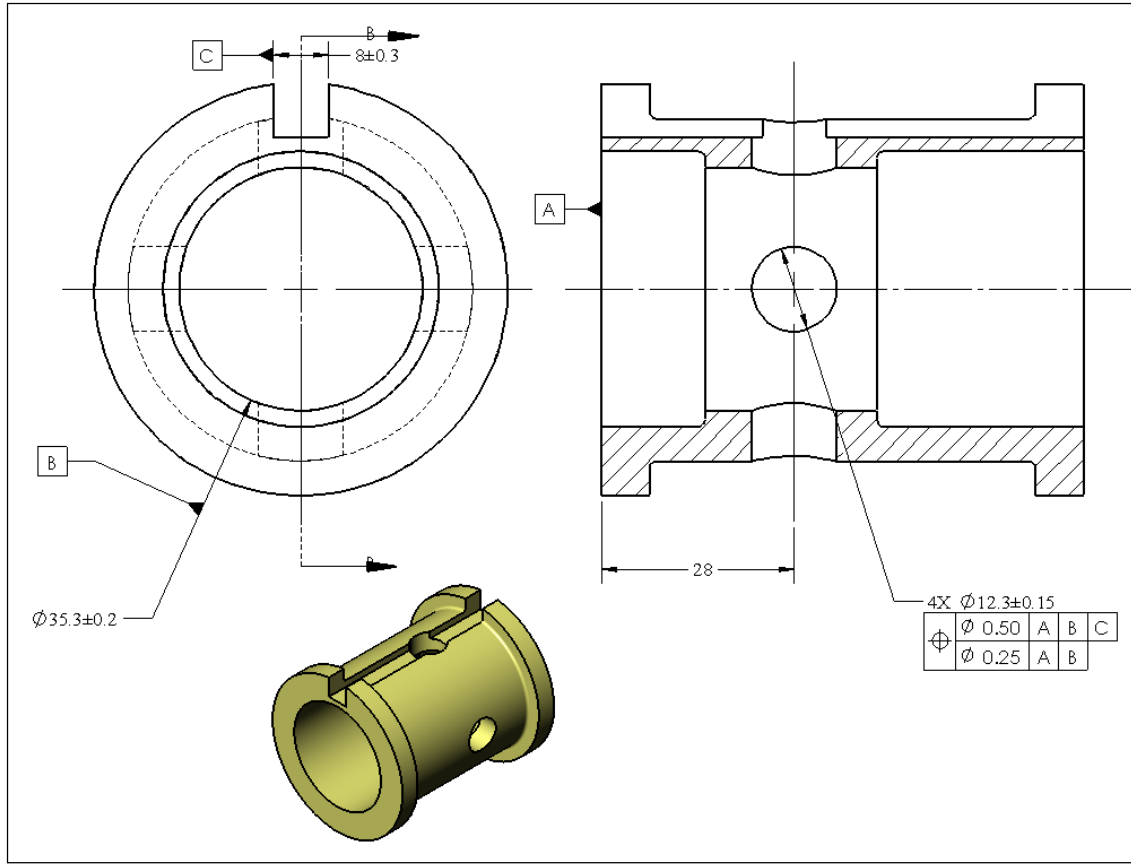
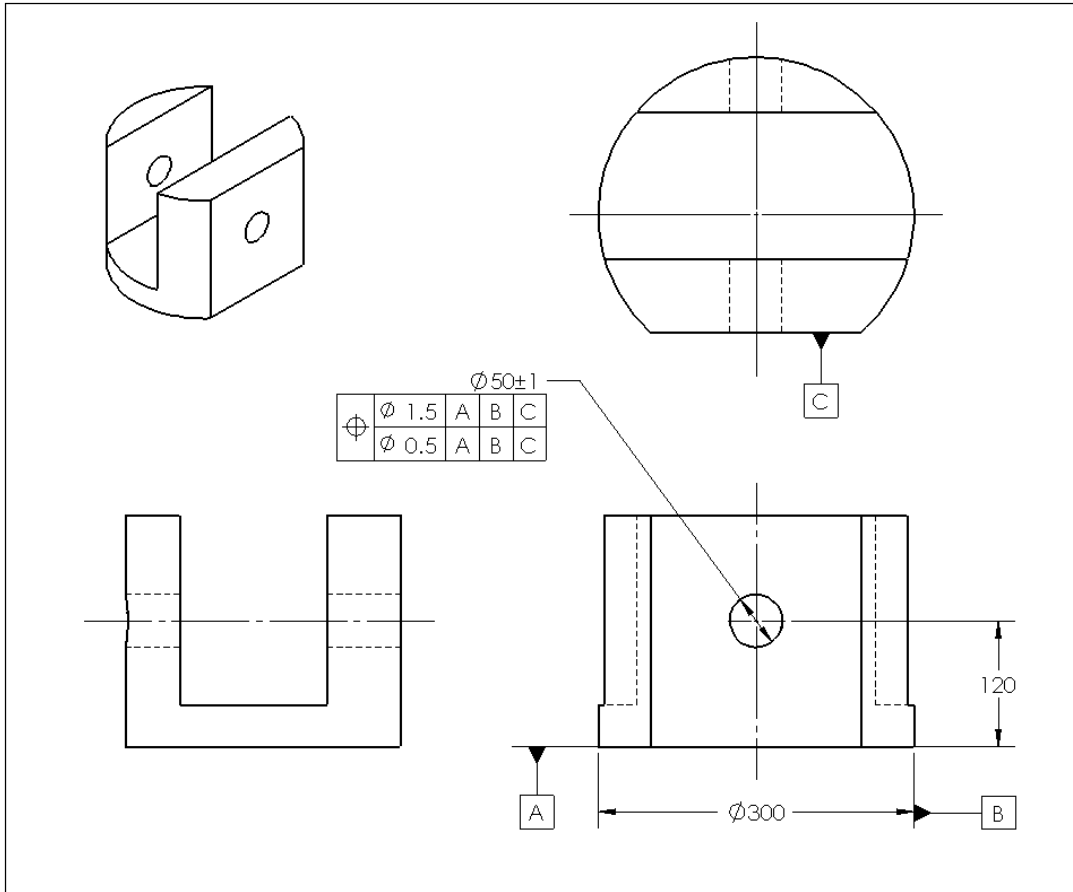


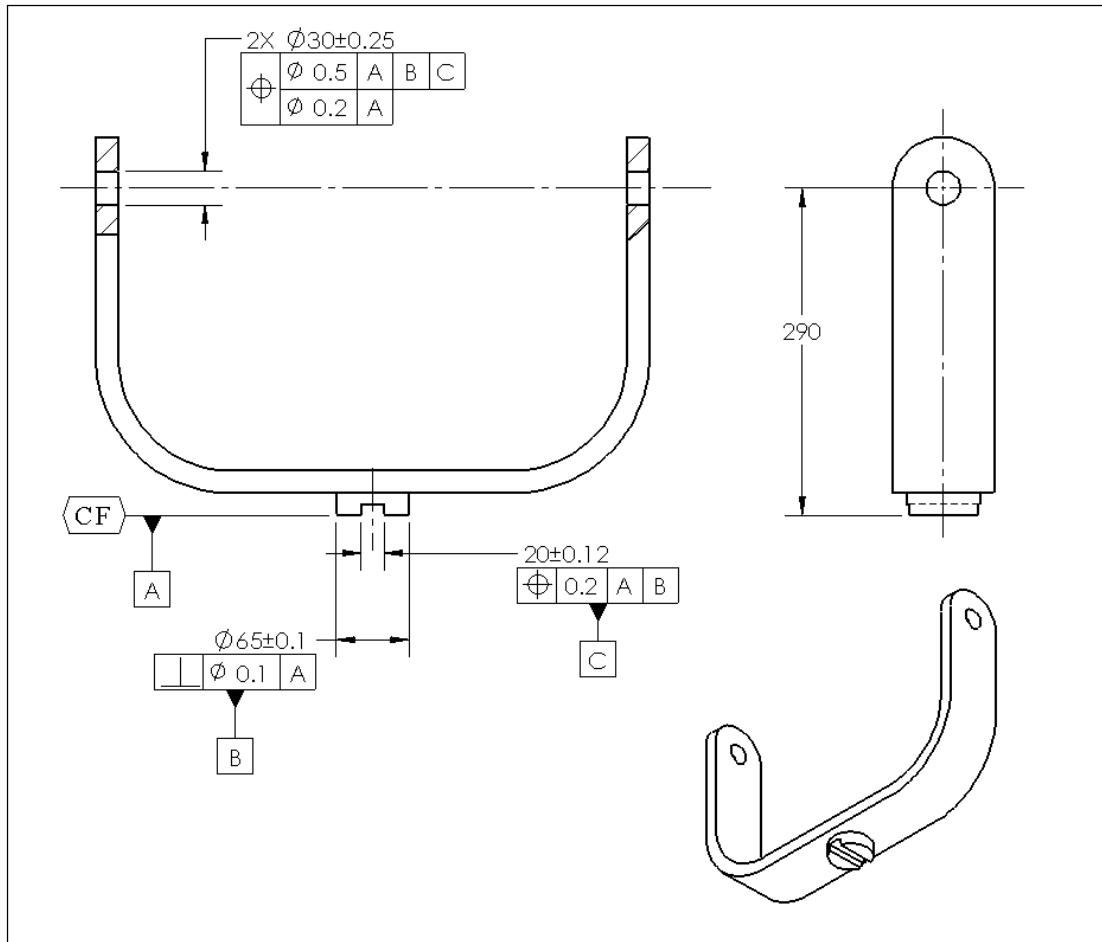
Figure 3-53. A part with a pattern of radial holes and a slot

5. Consider the part shown in Figure 3-54.
  - a) Draw the theoretical gage for the composite position tolerance.
  - b) Draw the theoretical gage when the  $\textcircled{M}$  modifier is used with the tolerance value.
  - c) Draw the theoretical gage when the  $\textcircled{M}$  modifier is used with the tolerance value, datum-B.
  - d) Read the standard and find out whether the  $\textcircled{M}$  modifier can be used with datum-C plane. If the  $\textcircled{M}$  modifier can be used on datum-C, draw the resulting gage.
  - e) Create the CAD model of the physical gage for part d).



**Figure 3-54. Part with coaxial radial holes**

6. Consider the part shown in Figure 3-55. Draw the theoretical gages for all tolerance statements. Also, draw the theoretical gages when the  $\textcircled{M}$  modifier is used with tolerance values.



**Figure 3-55. Part with U-shaped plate**

The symbol CF stands for “continuous feature”. The continuous feature symbol is used for interrupted surface features and designates the entire surface as the subject feature. In the case of this problem the datum feature A is the entire planar surface not just the half the datum label refers to.

7. Consider the 2D part shown in Figure 3-56 and the position tolerance statement applied to the hole on the top of the figure. The dimensions that define the theoretical location of the hole are not shown.
  - a) Create a theoretical gage for this tolerance statement.
  - b) Create a theoretical gage when the  $\textcircled{M}$  modifier is used with the tolerance value.

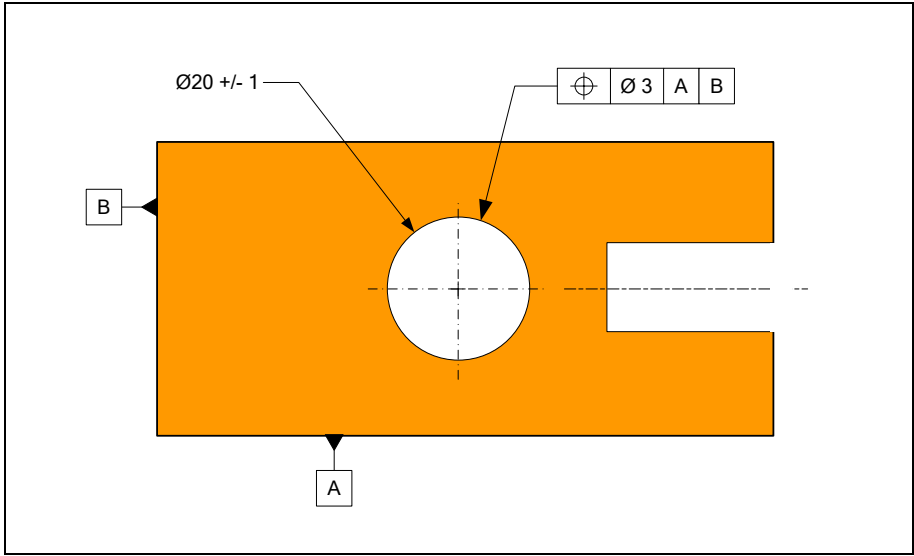


Figure 3-56. Position tolerance with A as primary datum and B as secondary datum

Consider the manufactured part is shown in Figure 3-57.

c) Is the location of the hole acceptable?

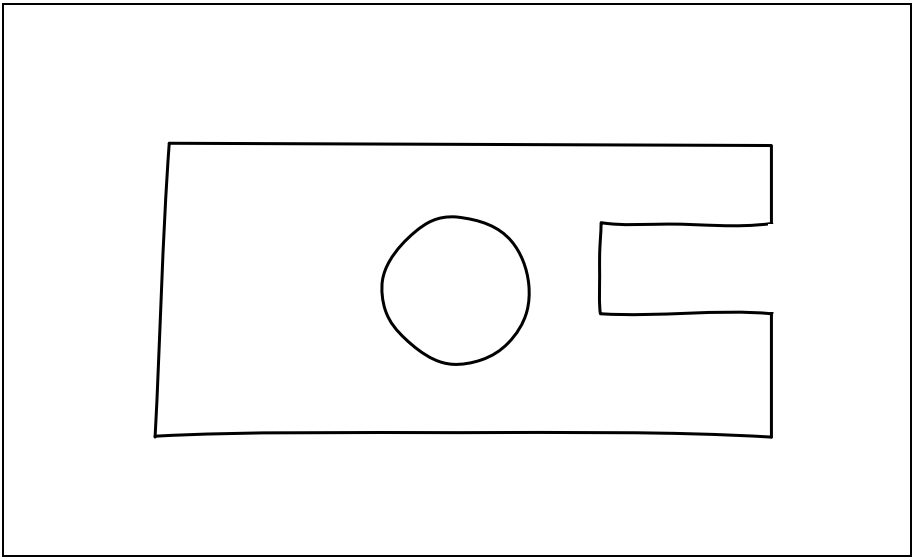
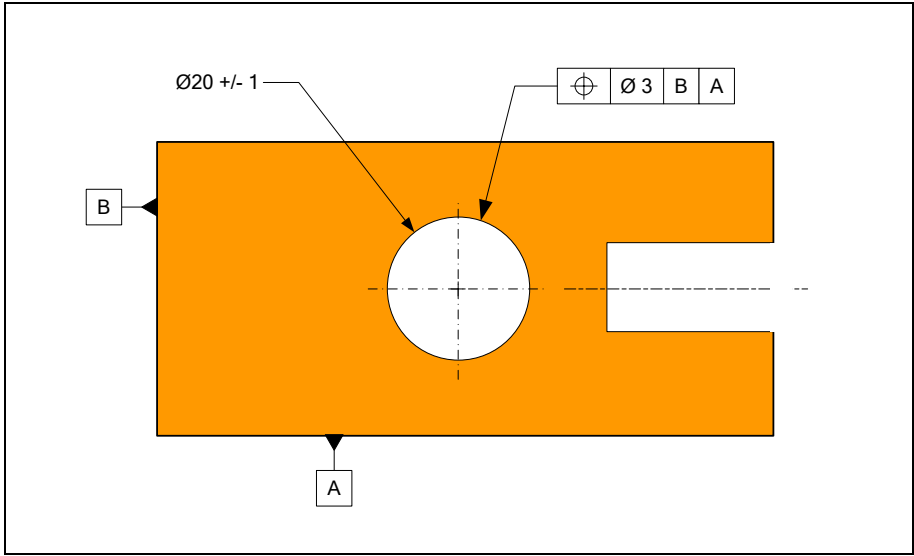


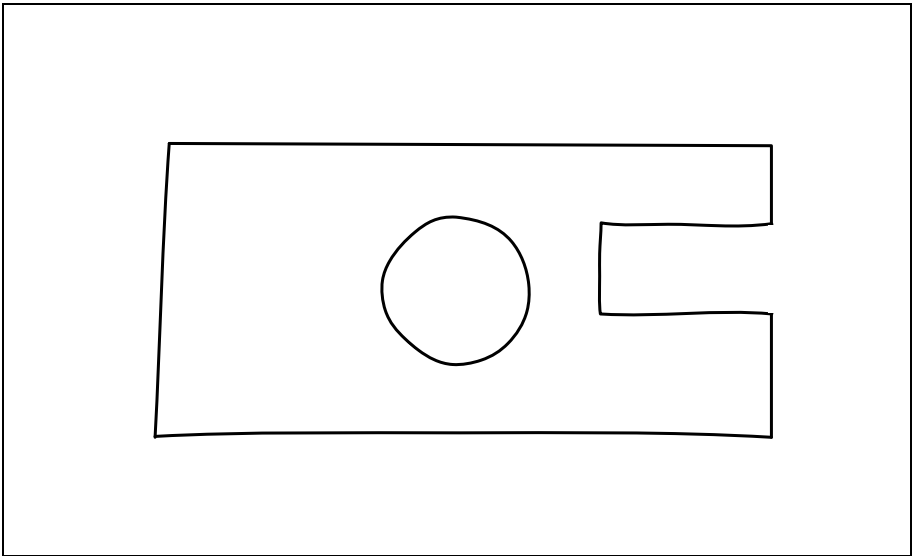
Figure 3-57. The actual part

8. Do the previous problem but this time with the datum priority reversed as shown in Figure 3-58.



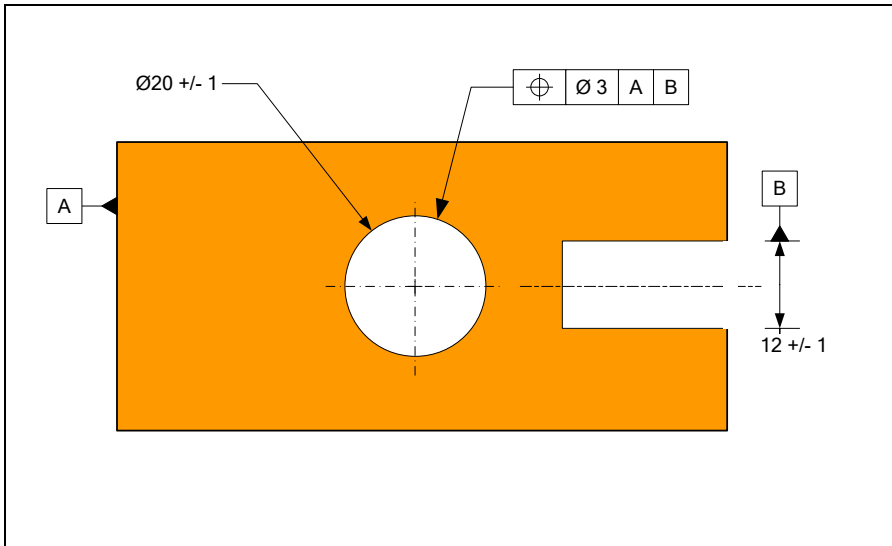
**Figure 3-58. Position tolerance with B as primary datum and A as secondary datum**

Consider the same manufactured part shown again in Figure 3-59.



**Figure 3-59. The actual part**

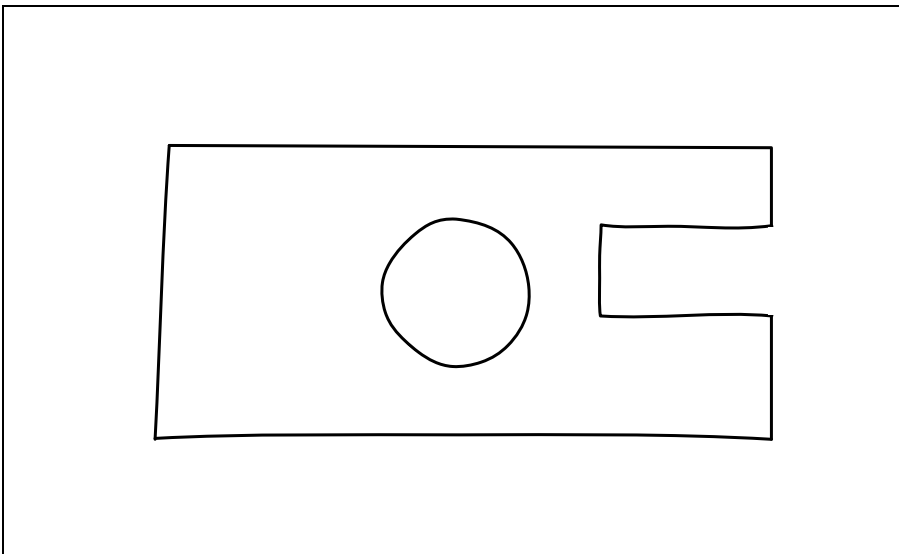
9. Consider the position tolerance specification shown in Figure 3-60.



**Figure 3-60. Position tolerance with datum-B as the slot center plane**

- a) Create a theoretical gage for this tolerance statement.
- b) Create a theoretical gage when the  $\textcircled{M}$  modifier is used with both the tolerance value and with datum-B.
- c) Is the location of the hole acceptable for each specification?

Figure 3-61 shows the manufactured part.



**Figure 3-61. The actual part**

10. For the specification shown in Figure 3-62
  - a) Create a theoretical gage for the tolerance statement.

- b) Is the feature acceptable?
- c) Create a theoretical gage when both datum-A and datum-B are specified at MMB. Both datum features have zero geometric tolerances associated with them (not shown).

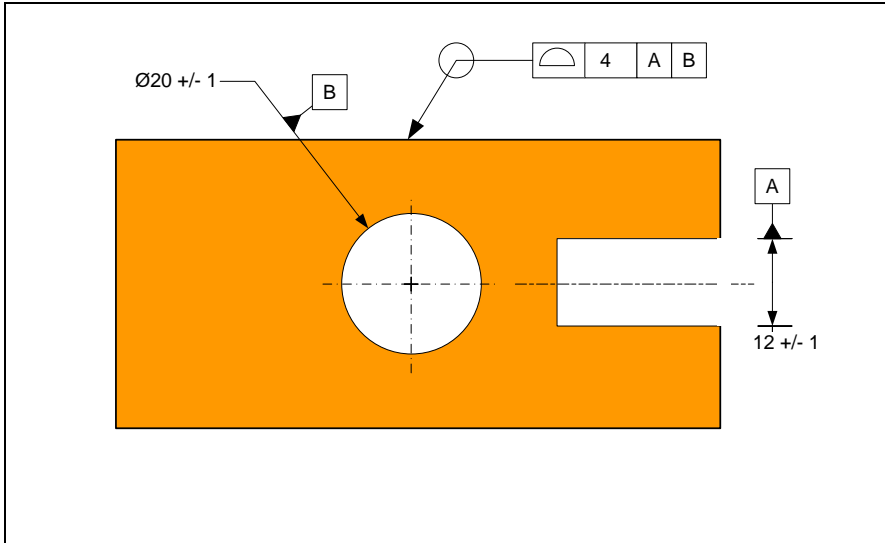


Figure 3-62. Profile tolerance

Figure 3-63 shows the manufactured part.

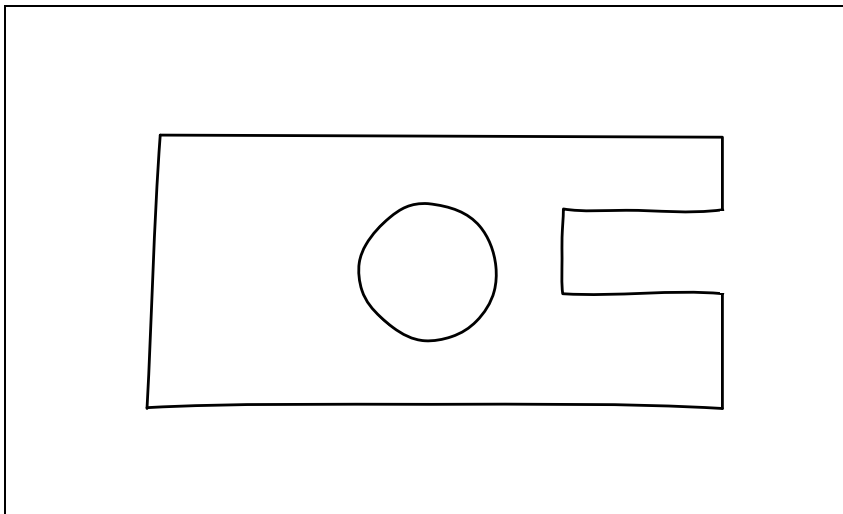
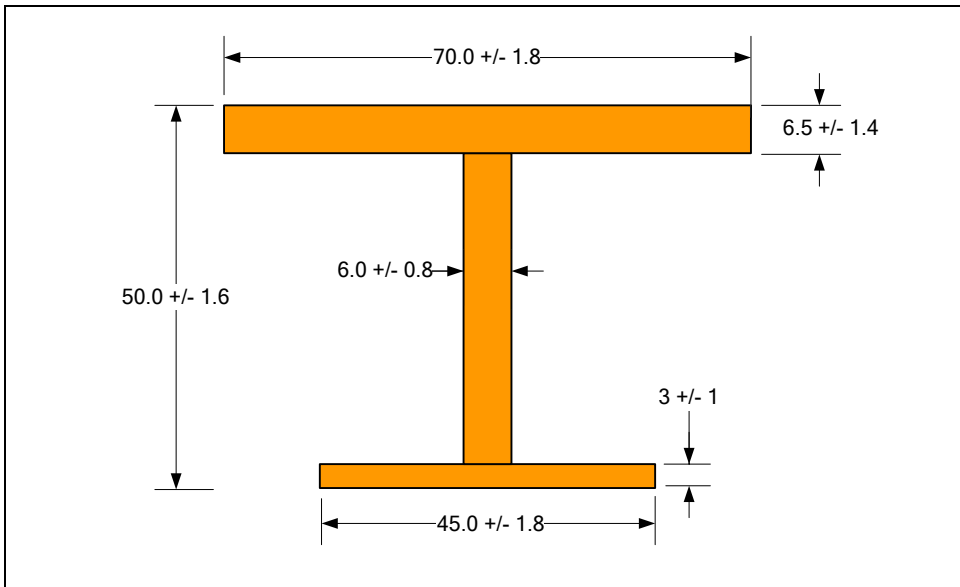


Figure 3-63. The actual part

11. Convert the dimension limits in Figure 3-64 to profile of surface tolerances. Convert all the vertical dimensions such that they are measured from the lower surfaces. Do

not label or show any datums in the tolerance statements. For horizontal dimensions, use the specification format that does not call for an origin of measurement.



**Figure 3-64. Convert  $\pm$  tolerancing format to equivalent profile tolerance format**

12. Read the GDT standard and look for a datum modification symbol that requires a datum feature to move and grip the part. Provide an example and explain the meaning of the specification.

# Chapter -4

## Default Tolerances

### 4.1. Overview

Default tolerances are tolerance statements that apply to a specific group or all geometric aspects of a part that have not been explicitly toleranced. For example, if a hole size is toleranced but its location is not toleranced, a default tolerance should apply to control the location of the hole. Otherwise, the manufacturing personnel are not responsible for the location of the hole even when the deviations well exceed manufacturing norms. Default tolerances play an important role in assuring that every part is completely toleranced before being sent to manufacturing.

When design engineers set up their drawings or CAD models for making prototypes, they often specify the tolerances for just a few precision features. In such cases, designers accept the outcome of the manufacturing process for non-precision features assuming that reasonable care is exercised during manufacturing. While adherence to adequate workmanship is expected from manufacturing personnel, having no verifiable requirements on the geometry of features is risky and unacceptable for production documentation used to produce thousands of parts. When tolerances are missing, the designer has no legal grounds to dispute the manufacturing quality even when there are gross mistakes in the part production. The use of default tolerances eliminates such risks. Default tolerance statements are verifiable just like other tolerance statements. Default tolerances, however, are only checked when there is an obvious mistake or lack of expected workmanship in the part production.

In general, default tolerances help design engineers by reducing the time it takes to explicitly tolerance every feature and by preventing inadvertent omissions. Every part should have its own custom-made set of default tolerances. It is an unwise practice to rely on company-wide policies, established default tolerances, historical records of tolerancing similar parts, or any other guideline that absolves the designer from carefully selecting the best default tolerances.

### 4.2. Default tolerancing methods

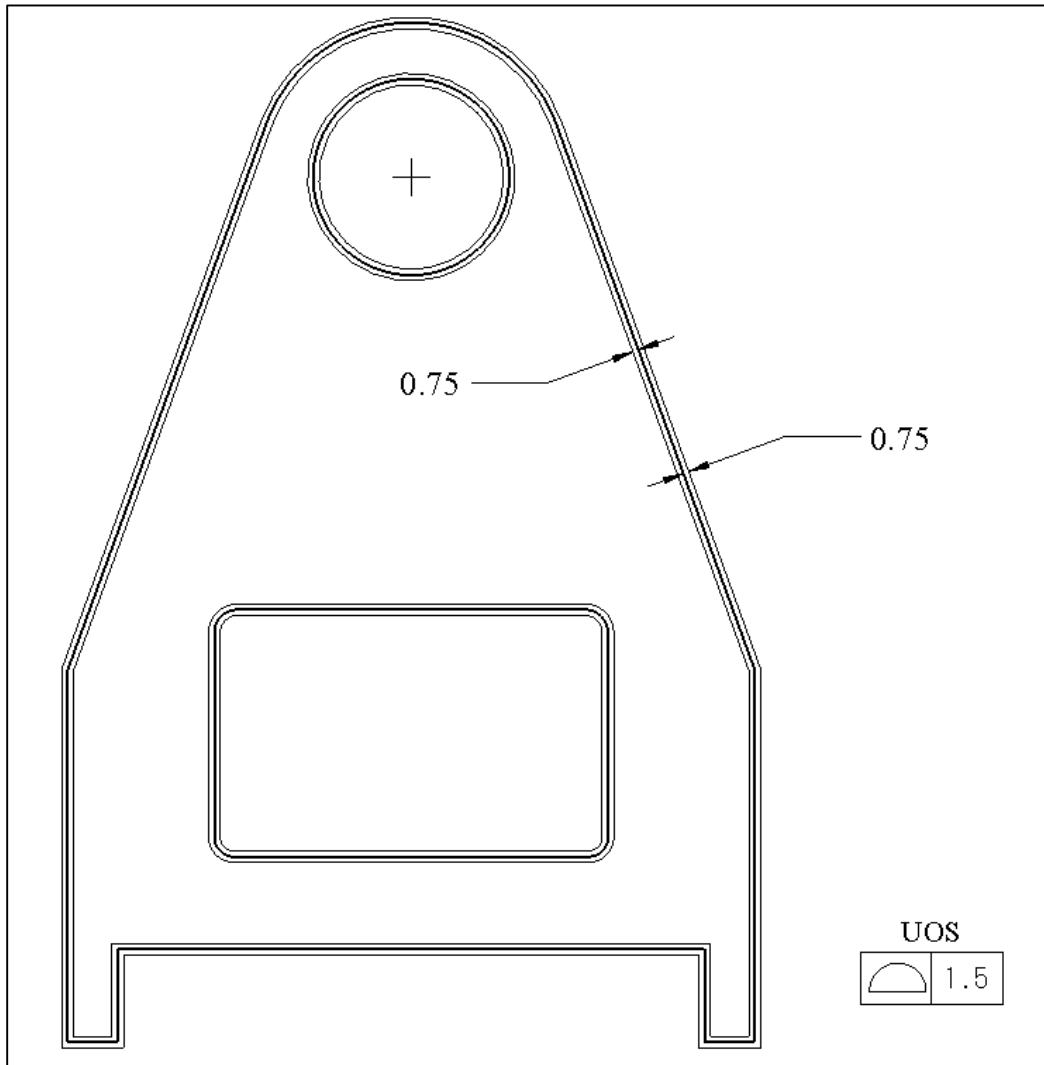
The common practice in default tolerancing is to place such tolerances in the title block of drawings as  $\pm$  limits on drawing dimensions and angles. The text “UNLESS OTHERWISE SPECIFIED” or UOS appears along with the specification. A title block tolerancing format similar to what is shown in Figure 4-1 is common.

UNLESS OTHERWISE SPECIFIED:
TOLERANCES:
ANGULAR: +/- 1 DEG
DIMENSIONS
x : $\pm 1$
.x : $\pm 0.5$
.xx : $\pm 0.25$

**Figure 4-1. An example of a typical title block default tolerances**

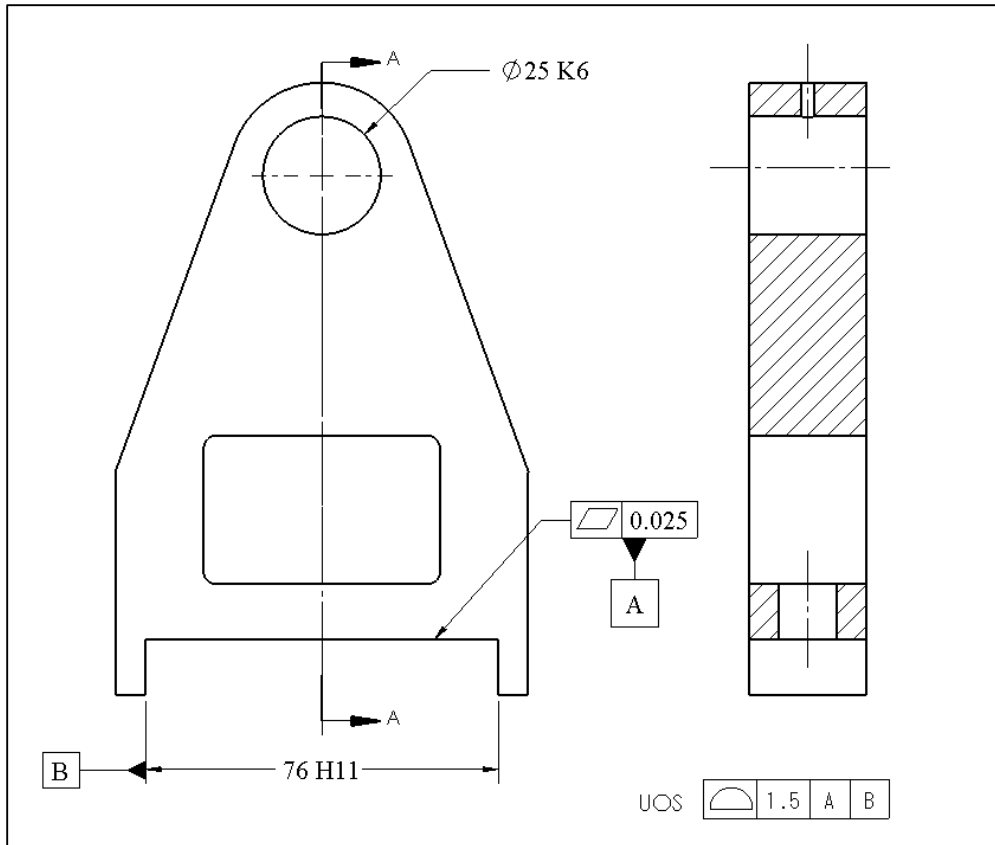
Based on this default tolerance block, a dimension shown as 25 on a drawing would be interpreted as  $25 \pm 1$  mm while the same dimension shown as 25.00 is interpreted as  $25 \pm 0.25$  mm. This scheme of default tolerancing has many drawbacks. For example, a change of formatting from one CAD installation to another can completely change the default tolerances. In addition, the dimensional tolerancing scheme is not feature-based requiring the designer to pay attention to every dimension of the part. The main objection to the use of default dimension limits is that it is incompatible with the geometric tolerancing methodology in which the CAD model and part dimensions define the theoretical or basic geometry of the part. For this reason, the use of default geometric tolerances is preferred over default dimensional tolerances.

Any geometric tolerance statement can be used as a default tolerance. The most common one is the profile of a surface tolerance that applies to all surface features of a part as individual features or as any grouping of features. A default profile tolerance defines a three-dimensional envelope around the entire part surfaces and thus controls every aspect of the part geometry to the degree specified by the tolerance value. For example, a default profile tolerance of 1.5 mm defines a theoretical gage as an envelope of thickness 1.5 mm around the basic geometry of the entire part as shown in Figure 4-2 for the turning support part. The primary manufacturing process for this part is machining from a plate and a 1.5 mm overall accuracy for the entire part is consistent with minimal level of manufacturing workmanship.



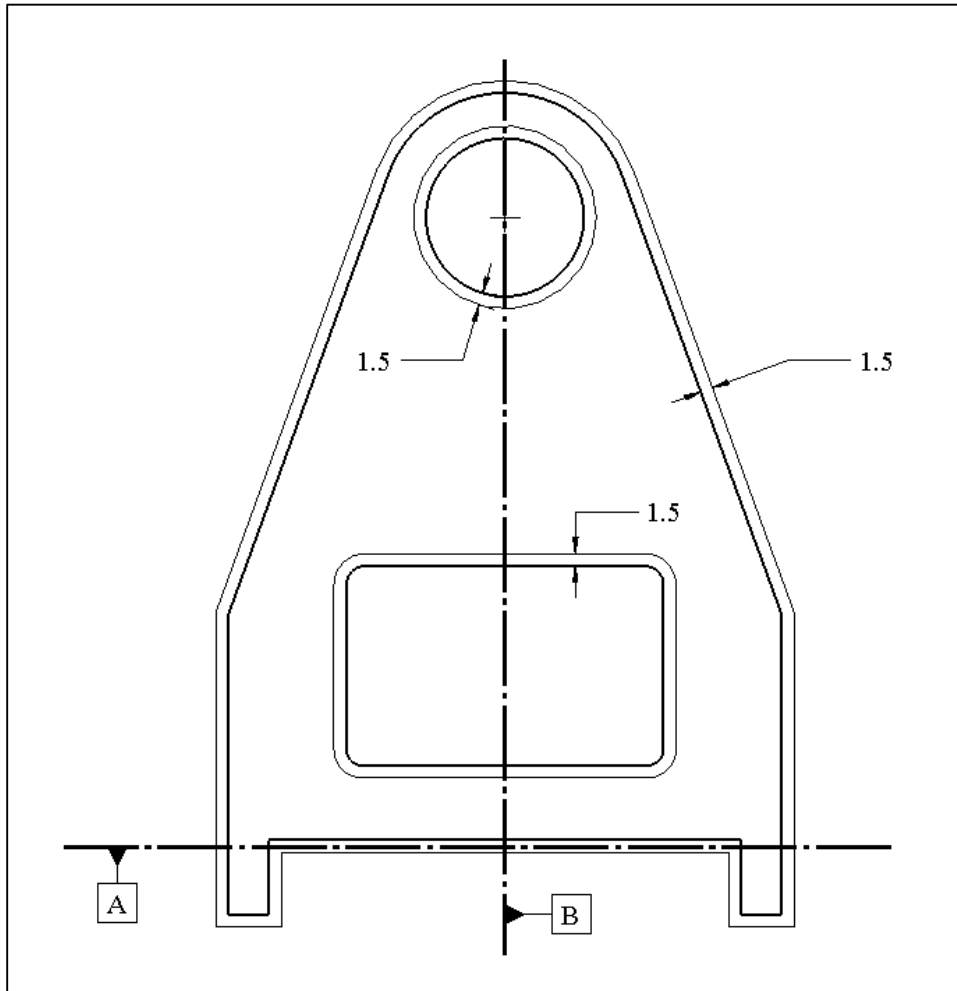
**Figure 4-2. Tolerance zone for profile of surface tolerance**

The 1.5 mm zone is divided evenly about the basic geometry definition of all features. A more suitable default profile tolerance would orient and locate the part features with respect to a datum frame. Adding a datum frame calls for the part features to be more accurately oriented and located with respect to the selected datum features. In the case of the turning support, the bottom surface and the slot center plane define a suitable datum frame. A default tolerancing scheme using this datum frame is shown in Figure 4-3.



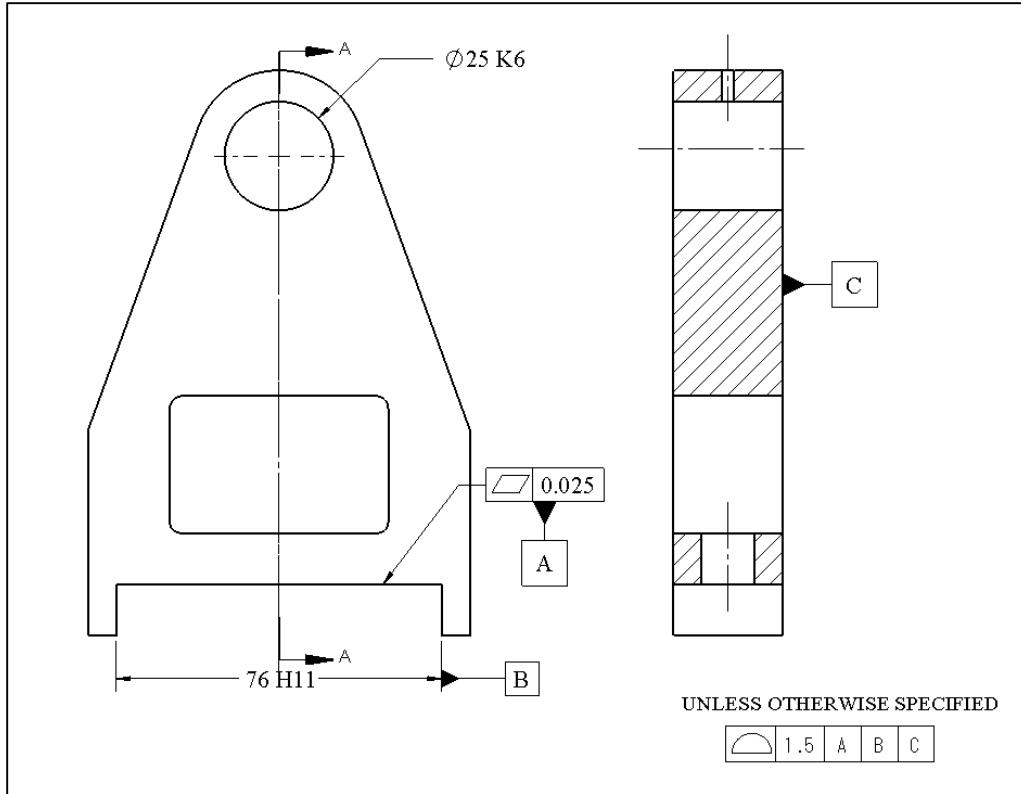
**Figure 4-3. Default profile of surface tolerance statement with datum references**

In this example, untoleranced features are oriented and located with respect to datum-A surface. The other locations (width-wise geometry) is controlled with respect to the plane of symmetry of the slot or datum-B. The theoretical gage for this default tolerance statement is shown in Figure 4-4. The theoretical profile, which is in the middle of the tolerance zone, is not shown.



**Figure 4-4. Theoretical gage for default profile of surface tolerance statement with datum references**

Default profile tolerances are preferred to have datum frames that fully fix the part to the gage. The profile datum shown in Figure 4-4 leaves the part with one unfixed degree of freedom relative to the datum frame. In order to completely fix this part we can select one of the faces of the turning support as a tertiary datum-C and reference that datum in the default profile tolerance as well. This is shown in Figure 4-5.



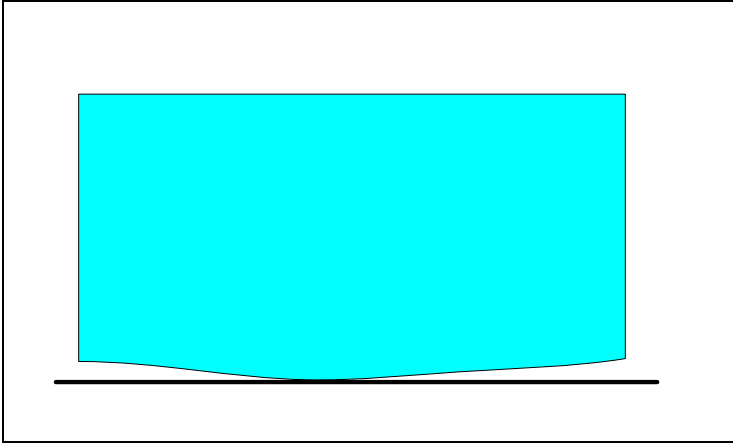
**Figure 4-5. Default profile of surface tolerance statement with fully constraining datum references**

In selecting the primary default datum feature, the design engineer must decide on the best orienting feature of the part. Usually, the part's mounting surface on the assembly is a good primary orienting datum. The secondary and tertiary datums for default tolerancing are usually the features that further locate and orient the part with respect to the assembly.

### **4.3. Datum targets**

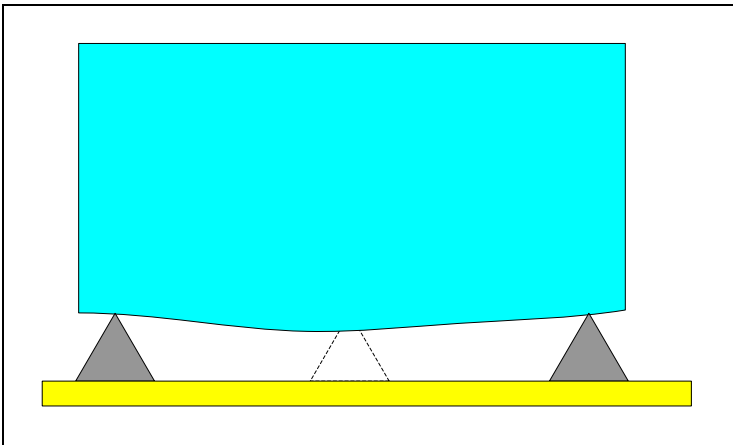
The primary application of datum targets is to set up default tolerance datum frames for parts that do not have precision surfaces. If we place a cast or forged part on any of its surfaces, the part is likely to be unstable. Datum targets allow such surfaces to be used as datums. Since the emphasis of this book is on machine design and machined parts, the discussion of datum targets that follows is brief. Engineers who design cast parts should become more familiar with various types of datum targets and their methods of specification.

Consider the bottom surface of a cast part shown in Figure 4-6. Because of the bowed shape, there is no repeatable way of aligning the planar datum simulator of a theoretical gage with this datum feature. If we place this part on a flat table, it would rock with a nudge.



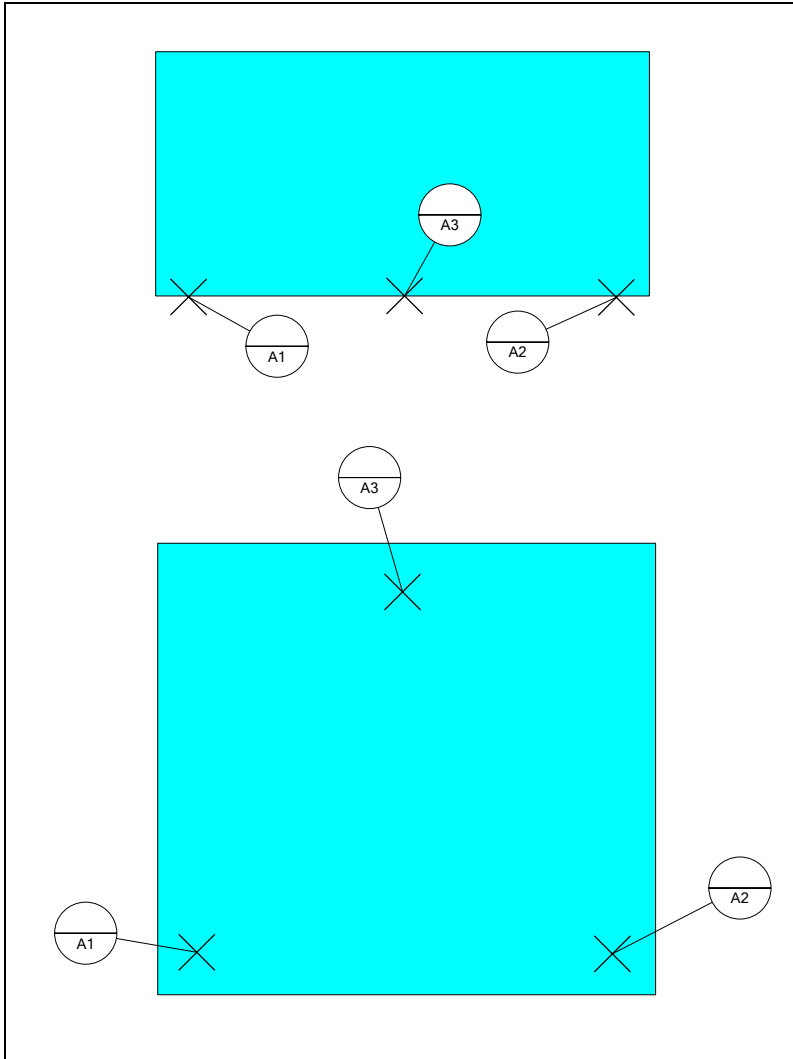
**Figure 4-6. A distorted surface would rock when placed on a flat surface**

In Figure 4-6, we would like to define a datum simulator that can create a good physical repeatable support for the part. A good way of supporting the part is to place the part on three points which are as far apart as possible from each other, without being too close to the corners and edges. The points must also be kept away from other surface anomalies like parting lines or weld beads. This procedure is shown in Figure 4-7. The figure shows two of the points in the front and a third point (with dashed lines) in the back.



**Figure 4-7. Datum targets allow unique datum assignments on uneven surfaces**

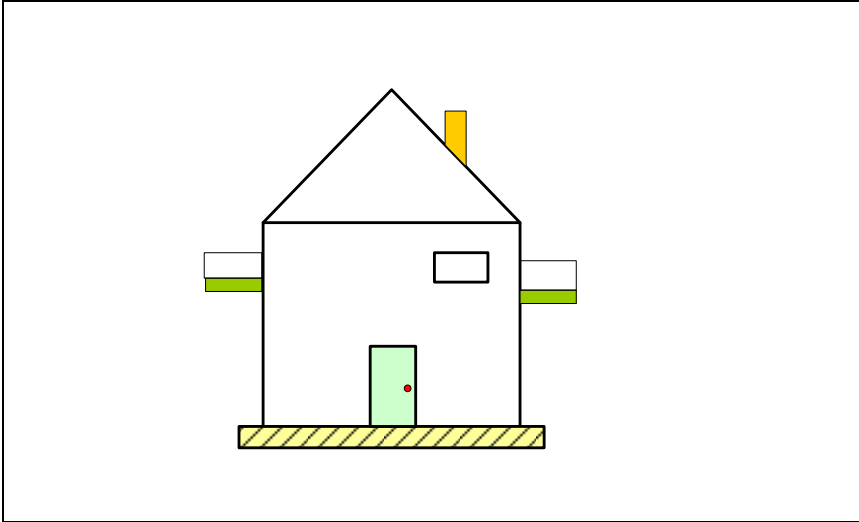
The design engineer can define the basic location of these target points using a datum target symbol. Figure 4-8 shows an example.



**Figure 4-8. The syntax for using datum targets to define the constraint geometry**

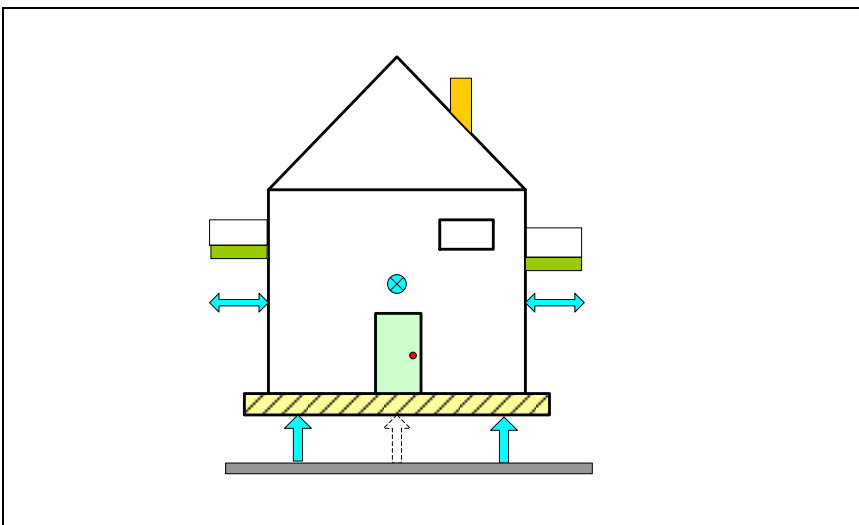
The three points labeled  $A_1$ ,  $A_2$ , and  $A_3$  define the datum-A plane. The basic distance between the datum targets and their distances to the part edges is defined by theoretical dimensions. Most CAD systems allow the designers to quickly insert datum targets. The designers can also specify a variety of other target tip forms such as spherical tips, cylindrical area tips, square area tips, edges, and even sliding datum targets. Any arrangement of points, lines, or surfaces that constrain a part can be used as datum targets. Sliding targets behave like expanding or contracting points or jaws with pointed tips or edges that grab the part and constrain the part's movements. By default, sliding targets move in the direction normal to the surface on which they are defined but other movement directions can be specified by notes.

For an example of using datum targets to define a datum frame for default tolerances consider the familiar example of a plastic toy house shown in Figure 4-9.



**Figure 4-9. A toy house**

The primary orienting datum for this shape would be the bottom surface of the house. We want all the surface features of this house to be more precisely oriented relative to the bottom surface datum. Datum targets will be used to define the surface as the plastic molded surfaces are uneven. To establish the primary datum, three datum target points would be used. The datum simulator would consist of three pins on which the house rests (datum plane-A). The targets defining the primary datum are shown in Figure 4-10 as three arrows on the bottom surface. The arrow with the dashed outline is located near the back wall. The datum targets and the resulting plane define the general level of the house floor.



**Figure 4-10. Defining datum targets and datum simulators**

The secondary datum would locate all the features in widthwise direction. The secondary datum simulator can be a pair of collapsing points gripping the house from the sides.

These targets define a center plane datum and are shown by two-sided arrows. The tertiary datum can be a point in the center of the front or back wall. Once the house is set up on the datum targets and immobilized, profile tolerance zones can be used to define the extent of surface variation from the theoretical shape of the house. This profile statement must have a value consistent with the tolerances that plastic molding practices can easily hold when there are no errors in the process.

Default tolerances should be selected to best define the shape of a part and be insensitive to local shape variations. This usually means placing the targets far apart on the most prominent features of a part. Datum targets can also be used on machine parts for default tolerance specification when the part's precision surfaces do not best represent the overall shape of the part or are too small.

#### 4.4. Default tolerancing and small features

One of the weaknesses of the default profile tolerancing is that a profile tolerance value that is adequate for the entire part would usually not provide sufficient control for non-precision small features such as small holes or bosses, grooves, fillets, webbings, chamfers, ribs, etc. For example, if the 3-mm oil hole in the turning support part is left without explicit tolerances, the profile default tolerance applies to it. For this small feature, the default tolerance creates a relatively large acceptance zone as shown in Figure 4-11. The 3-mm hole size can be as small as 1.5 mm or as large as 4.5 mm. It can also be off center or tilted by several degrees. Even though this lubrication hole is not a precision feature and may still function adequately, this amount of variation is usually indicative of poor workmanship or other manufacturing problems.

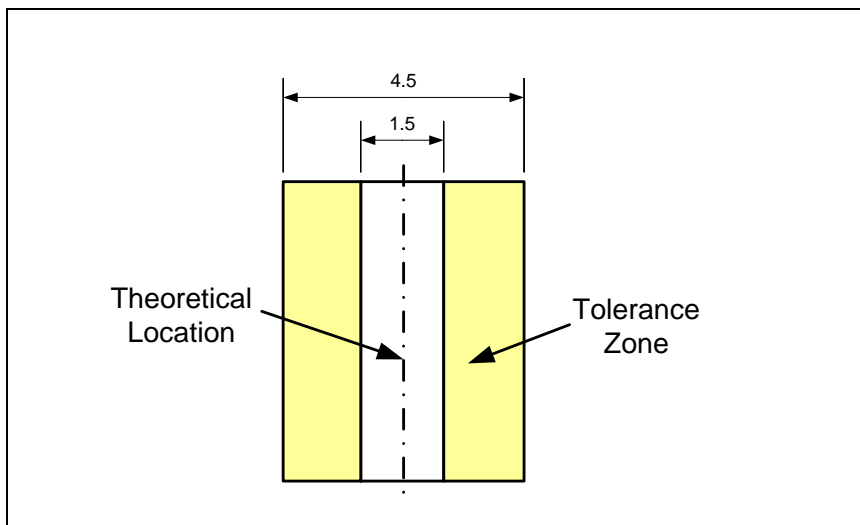
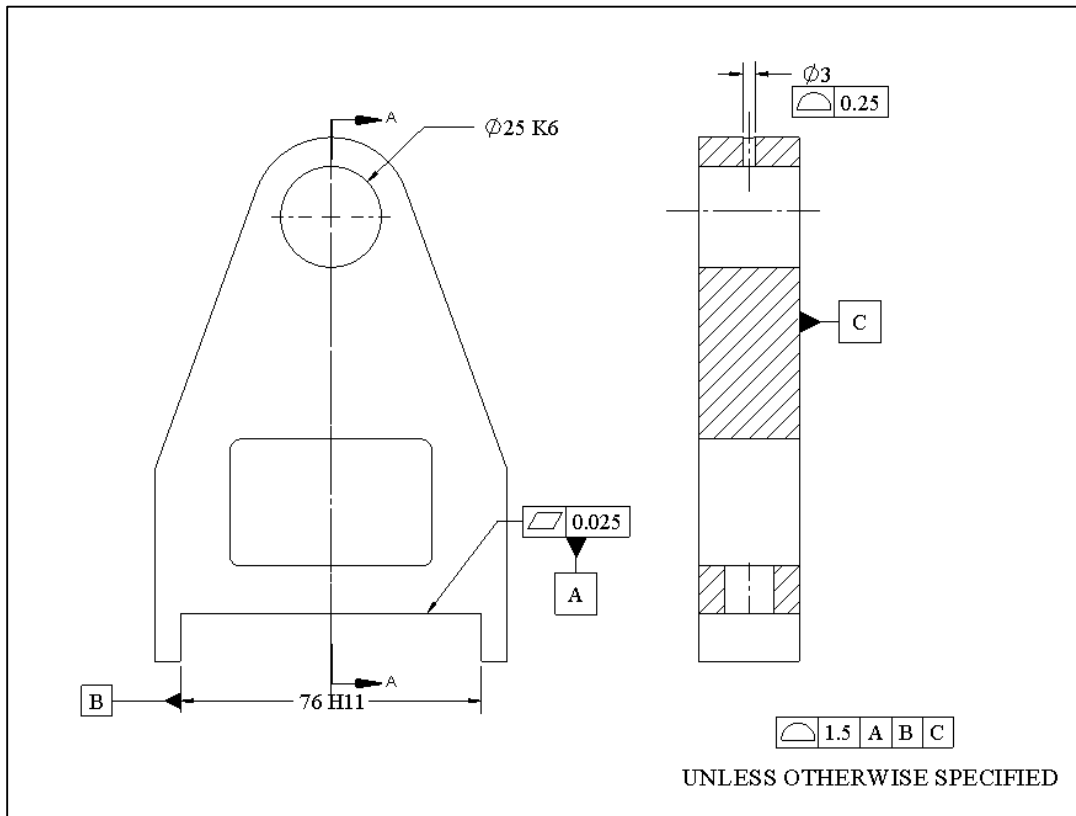


Figure 4-11. Default profile tolerance zone for a small hole may not provide adequate control

To address the accuracy of small features the designer should consider tolerancing small features directly rather than relying on the default tolerance. Explicit profile tolerances should be added to control the sizes and, if necessary, the locations of small features.

Figure 4-12 shows the final specifications for the turning support part where the size of the lubrication hole is controlled by a separate profile statement that calls for more size precision while still consistent with minimal expected precision of manufacturing practices. The location of the hole is left unspecified to be controlled by default tolerances.

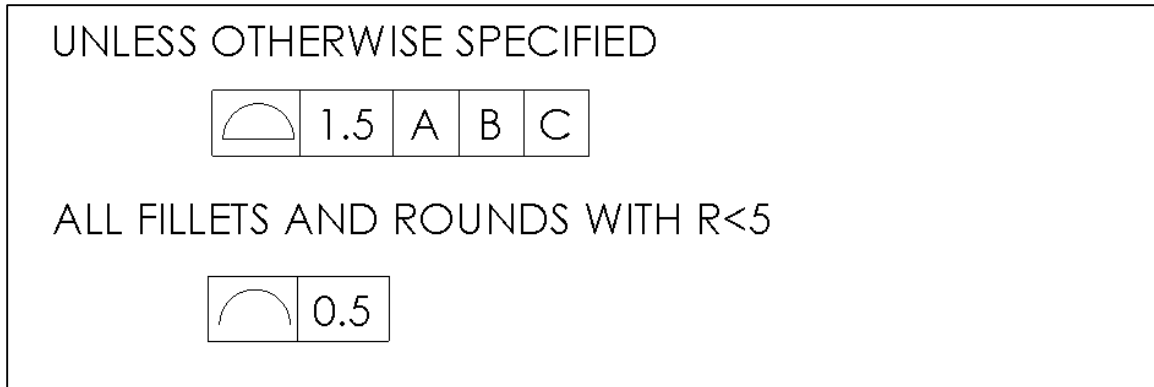


**Figure 4-12. Small features may require explicit tolerance statements**

This part would be fully defined when the design dimensions are imported into the drawing. It is usually a good practice to place the dimensions and tolerances on two separate layers such that each can be generated separately or together as in customary production drawings.

#### **4.5. Default tolerances for fillets and rounds**

A part may have many fillets and rounds on many of its edges. Since these features are usually small, default tolerance values for overall dimensions may even exceed the radii of some fillets. These small features need to be controlled by narrower tolerances to ensure their shapes are produced with reasonable accuracy expected from the intended manufacturing process. One way of controlling such features is by one or more profile statements applicable to identifiable features such as fillets and rounds. For example, a default tolerance statement such as the one in Figure 4-13 may be appropriate.



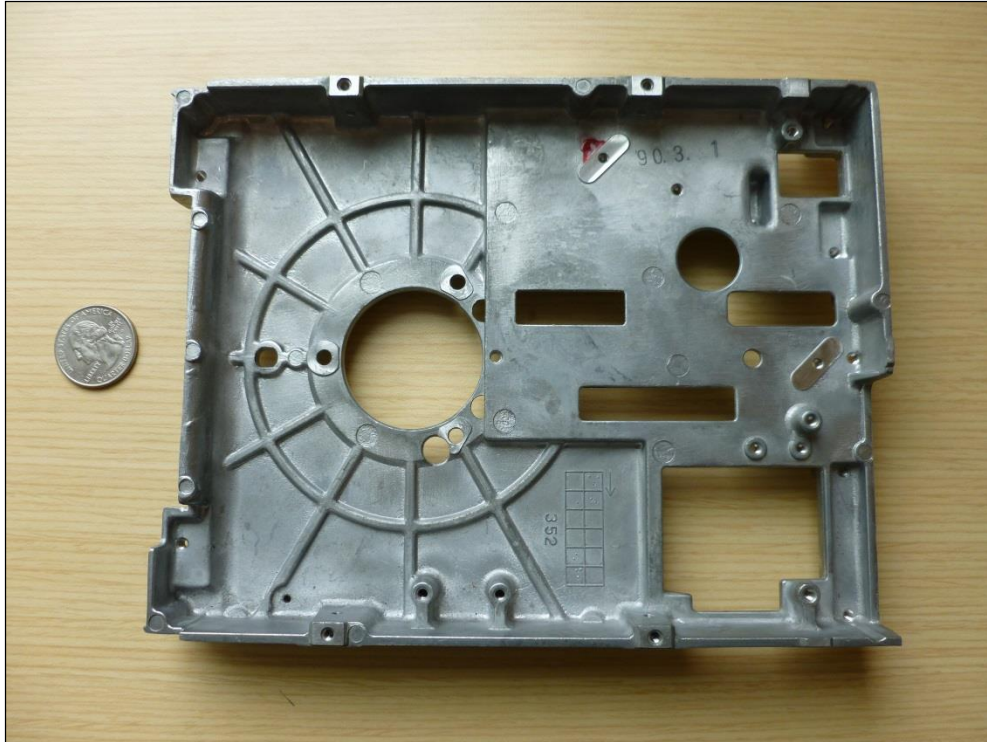
**Figure 4-13. Default tolerances including a statement for the size of small fillets and rounds**

Small features such as small holes, webbings, chamfers, grooves, notches, or counter-bored features may require similar tolerance statements either explicitly applied to the features or as a default tolerance applied to named feature types.

Care must be exercised not to create a long list of default specifications. As a preferred practice, default tolerance statements should be kept to a minimum. For example, a default tolerance that applies to just one or two features is best applied directly to those features. A manufacturing establishment would normally scan the default tolerances ensuring that their processes are well capable of meeting them and afterwards the default tolerances are ignored. Default tolerances that require levels of precision beyond just basic workmanship should be avoided.

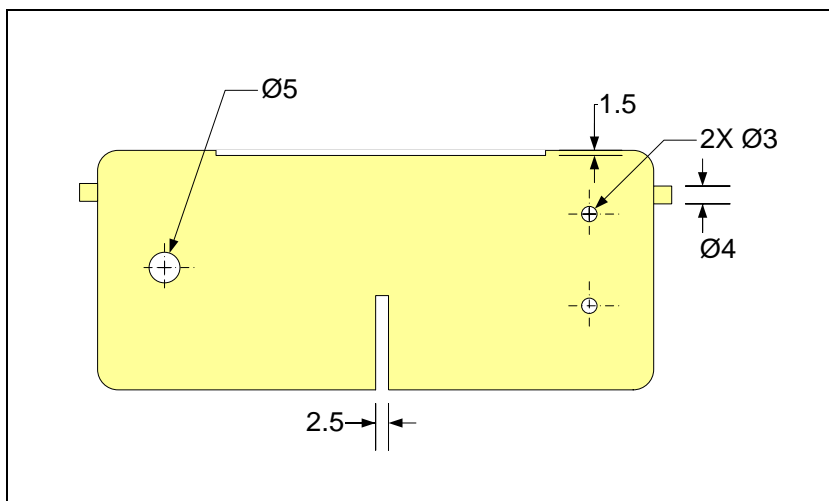
#### **4.6. A different way of dealing with small features**

Typical cast parts have a lot of small features and details and it is not always possible to clearly name and identify their types on a model. Unless the default tolerancing scheme can accommodate these small features, they would need to be directly toleranced. As a result, the list of small features that need their own explicit tolerance statements on a complex cast part can become extensive. An example of a cast part is shown in Figure 4-14.



**Figure 4-14.** A cast part with many small non-precision features

We only needed one statement to require adequate workmanship for the larger-scale features of the part. Ideally, we should need just one more statement to require adequate workmanship to control the smaller-scale geometry of a part. This can be accomplished with a special kind of profile statement. The needed profile tolerance statement must use an adjustable tolerance value. The tolerance value becomes smaller as the feature become smaller. For illustration, consider the geometry shown in Figure 4-15.



**Figure 4-15.** A part with many small but non-precision features

This shape has a shallow slot, three small holes, a deep groove, and two small side bosses. Assume that none of these features are precision but they are required to be made with a minimum level of size accuracy expected from good workmanship using adequate manufacturing processes. To meet the requirements, we can define a profile tolerance with an adjustable tolerance value. The tolerance value would depend on the size of the zone of inspection. The smaller the zone of inspection, the smaller the tolerance value would become.

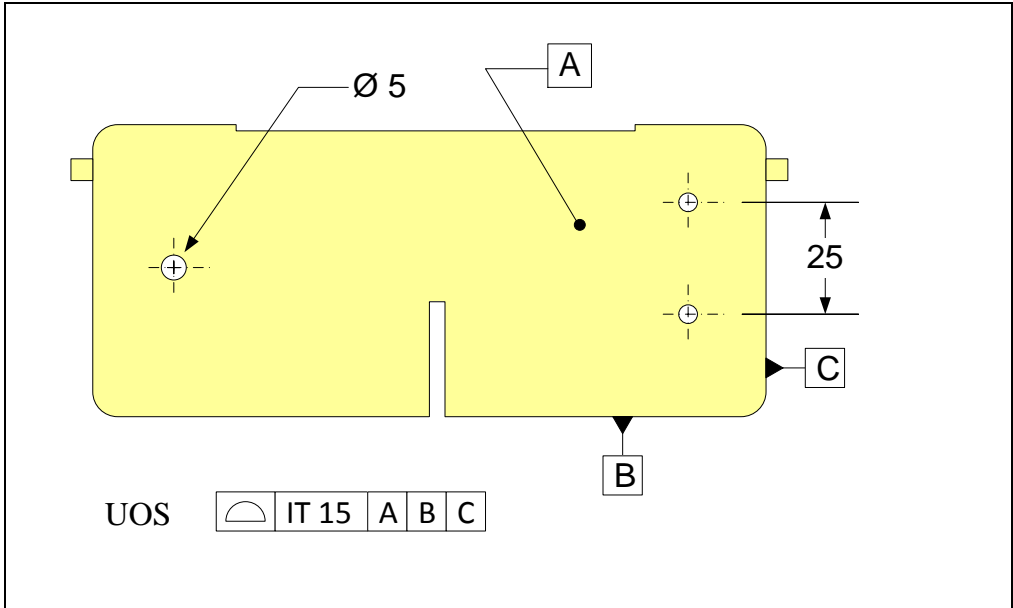
At first, the variable tolerance zone method appears to make things complicated both for design engineers who specify them and for manufacturing personnel, who like to know immediately if they can meet the minimal precision requirements. Fortunately, size-adjustable tolerance values have been standardized and are known as the International Tolerance grades or IT grades. We will cover the IT grades in more detail in Chapter-6. A portion of the IT grades table is shown in Table 4-1 for illustration.

Feature Sizes	IT Grades					
	IT 12	IT 13	IT 14	IT 15	IT 16	IT 17
<b>0-3</b>	0.10	0.14	0.25	0.40	0.60	1.0
<b>3-6</b>	0.12	0.18	0.30	0.48	0.75	1.2
<b>6-10</b>	0.15	0.22	0.36	0.58	0.90	1.5
<b>10-18</b>	0.18	0.27	0.43	0.70	1.10	1.8
<b>18-30</b>	0.21	0.33	0.52	0.84	1.30	2.1
<b>30-50</b>	0.25	0.39	0.62	1.00	1.60	2.5
<b>50-80</b>	0.30	0.46	0.74	1.20	1.90	3.0
<b>90-120</b>	0.35	0.54	0.87	1.40	2.20	3.5
<b>120-180</b>	0.40	0.63	1.00	1.60	2.5	4.0

**Table 4-1. A portion of the table of International Tolerance Grades**

Based on this table, a tolerance value of 0.4 mm applies to a 2 mm hole when the tolerance grade of IT-15 is selected. The default tolerances for every process can be associated with an IT grade. For example, a reasonable default tolerance grade for general machining may range from IT-12 to IT-15 while a tolerance grade range for various casting processes can be between IT-14 and IT-17. We can even use Table 4-1 to come up with adequate values for the overall default tolerance as well. For example, the largest dimension of the turning support part in Figure 4-12 is 130 mm. Selecting an IT-15 grade for this part, for which the primary manufacturing process is machining, we can select a tolerance value around 1.6 mm. In the case of the turning support a value of 1.5 mm was applied as the overall default tolerance.

In Figure 4-15, the sizes of small holes, the width of the deep groove, and the depth of the slot are controlled by a 3 mm size zone of inspection. A profile tolerancing scheme for controlling the size of small features of the part is shown in Figure 4-16.

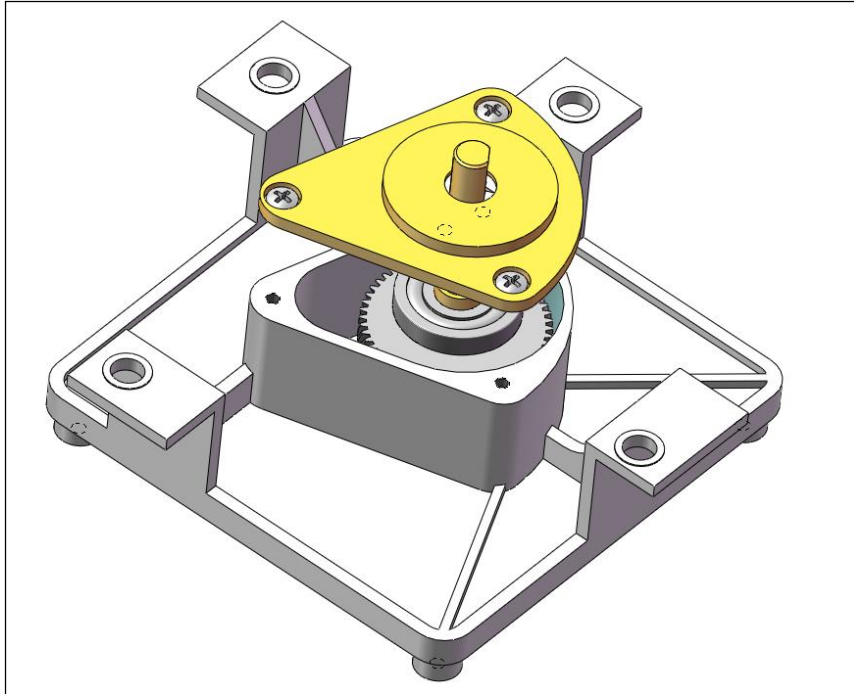


**Figure 4-16. An example of a profile tolerance statement with an adjustable tolerance value**

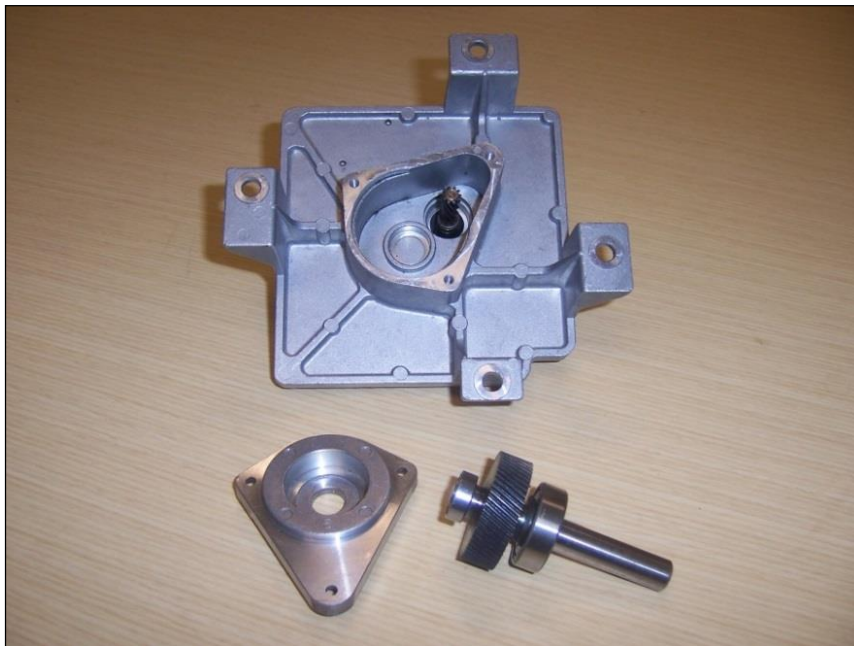
Based on this specification, the sizes of the 3-mm holes are controlled by a profile tolerance with a tolerance value of 0.4 mm. The size of the deep groove and the depth of the shallow slot are also controlled by a 0.4 mm tolerance zone. The size of the 5-mm hole is controlled by a tolerance value of 0.48 mm. The distance between the two smaller holes is controlled by an inspection zone that includes both features resulting in a profile tolerance with a tolerance value of 0.84 mm.

**A default tolerancing example for a die-cast gearbox housing**

Figure 4-17 is a simplified model of a gearbox. The gearbox housing is made of die-cast aluminum. It has many ribs and reinforcing features but except for a few surfaces that require machining, the rest of its features are non-precision. Figure 4-18 shows the actual assembly.

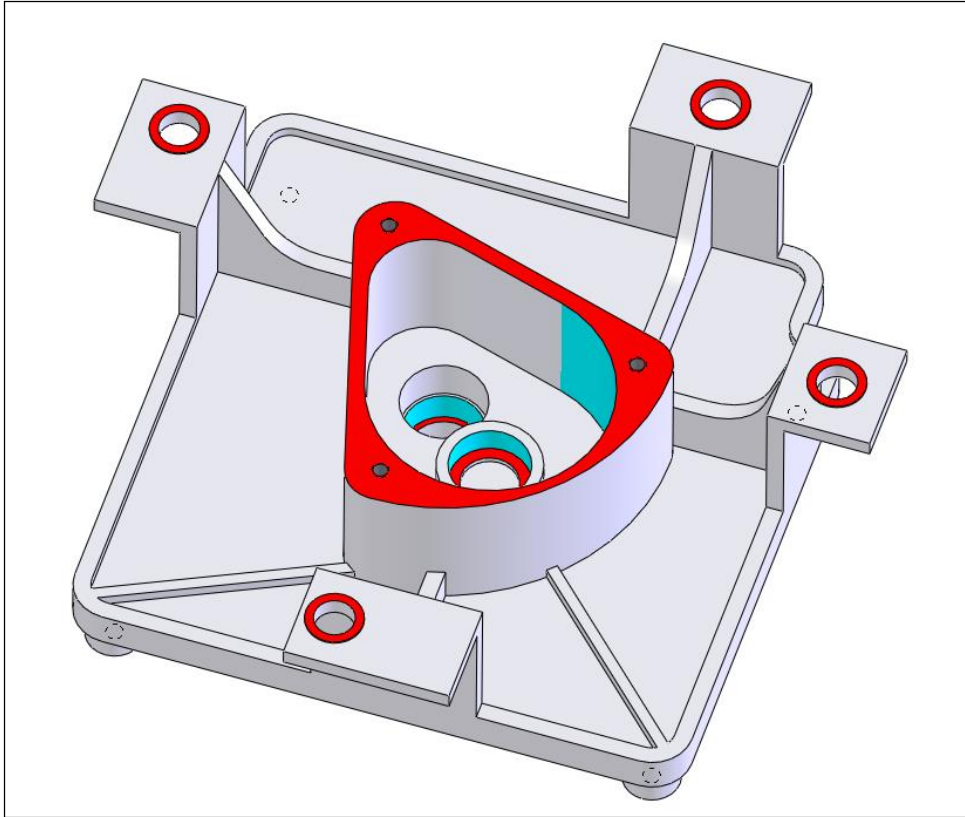


**Figure 4-17.** The simplified assembly model of a gearbox



**Figure 4-18.** Components of a gearbox

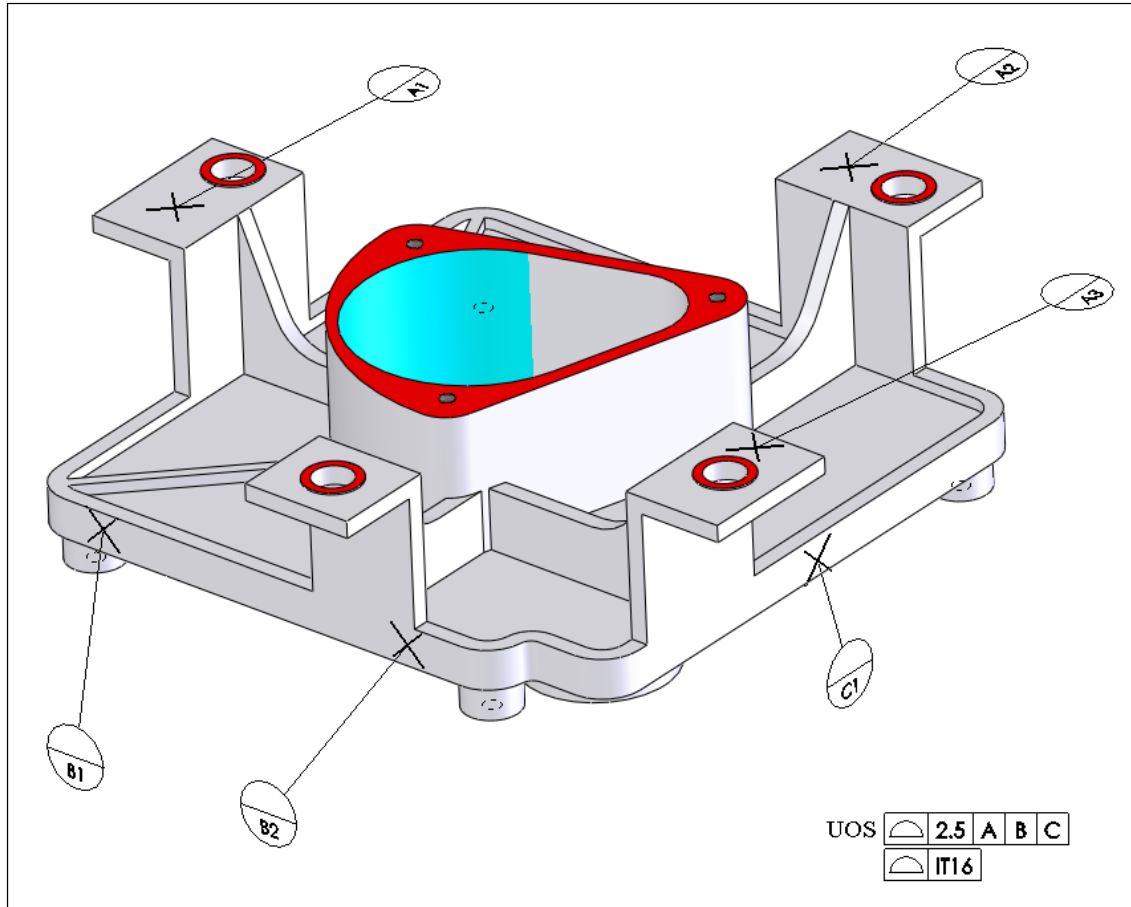
Figure 4-19 shows the surfaces of the gearbox housing that require precision specification. These surfaces are highlighted in color.



**Figure 4-19. Precision features of the gearbox housing**

The highlighted flat surfaces, shown in red, are contact surfaces and must be machined flat. The highlighted cylindrical surfaces, shown in blue, must be machined for fit of the bearing outer diameters and for the fit of the endcap. The location of the tapped screw holes must also be controlled with precision. Other surfaces are non-precision and are left as-cast. The cast features can be controlled with default profile statements.

To define the profile statement necessary to control the large-scale geometry of the gearbox housing we must define a suitable datum frame. Figure 4-20 shows the selection of the default primary datum using three datum target points. The target points are selected far apart to promote stability and insensitivity to local deformations. Notice that the machined surfaces are not selected to define the primary datum; instead points on the cast features are used. It is usually preferred to define the datum targets based on the surfaces that represent the primary manufacturing process. The secondary and tertiary datum targets are placed on the two edges of the part as shown.



**Figure 4-20. Datum targets defining the primary datum**

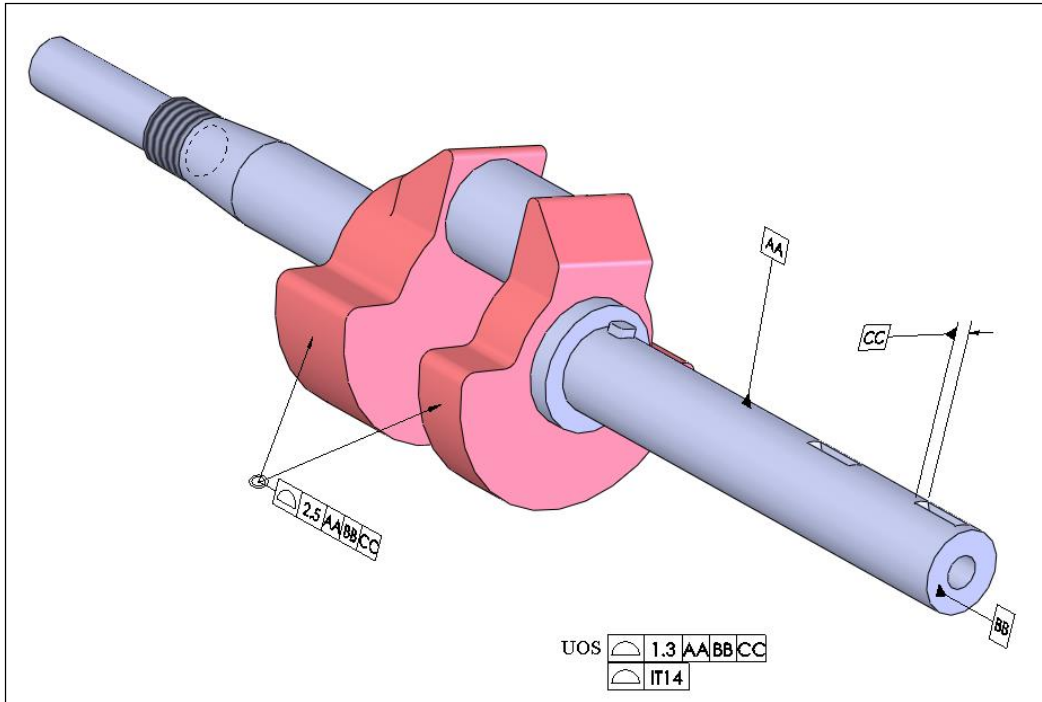
The default tolerance datum frame, along with the two profile statements shown on the figure, complete the default tolerancing requirements of this part. The 2.5 mm profile tolerance value is consistent with IT-16 grade for a part that has a largest overall dimension in the range of between 120 and 140 mm.

Sometimes it is best to set up the default tolerances based on the precision of the secondary process. Figure 4-21 shows the picture of the crankshaft of a small single-cylinder engine. The primary manufacturing process is sand casting. The counterweights are not precision features and remain as cast. The rest of the crank shaft surfaces are turned to achieve the desired precisions.



**Figure 4-21. The crank shaft of a single-cylinder engine**

In this case, it is better to set up the default tolerances based on the secondary machining process and explicitly tolerance the remaining cast features to have tolerances consistent with the precision expected of sand casting process. Figure 4-22 shows a simplified model of the crank shaft along with the default tolerance statements and explicit profile tolerances for the cast portions of the crankshaft. The cast portions are shown in red. There is no significance to labeling the datums by double letters such as AA, BB, or CC. You may use such labeling schemes as visual aids to distinguish between datums exclusively used for default tolerancing purposes versus other functional purposes.

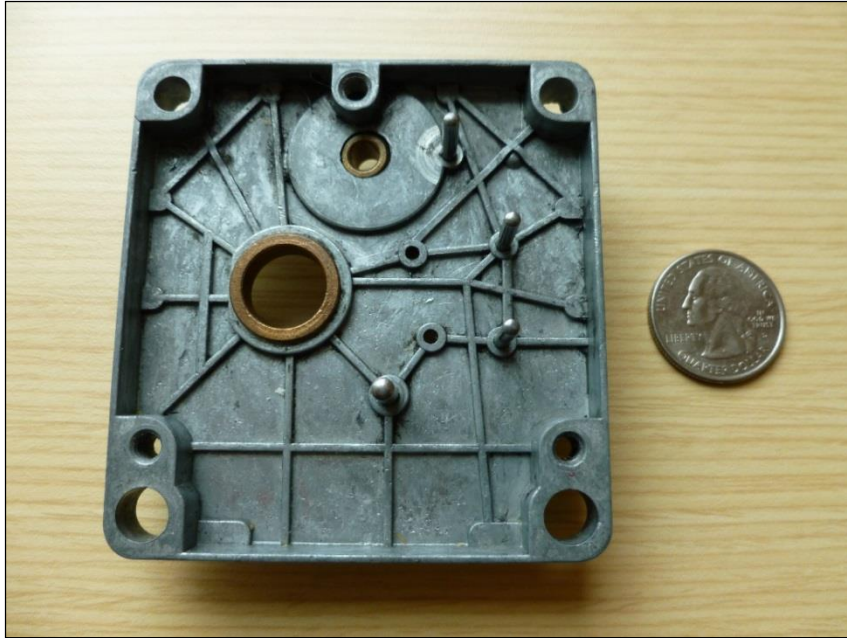


**Figure 4-22. The model of the crankshaft of a single-cylinder engine**

The default profile tolerances control the machined features of the crankshaft while the explicit profile tolerance statement applied to the cast part allows tolerance values larger than that in the default statement.

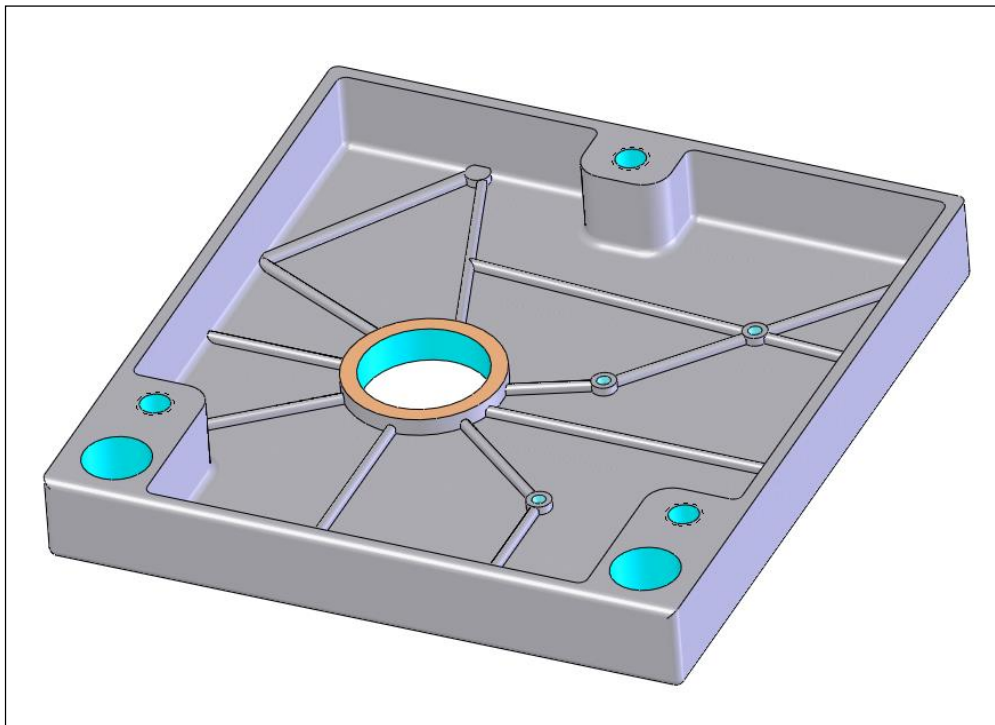
### **Exercise Problems**

1. Consider the gearbox housing cover shown in Figure 4-23. This aluminum die cast part has many small features such as ribs, fillets, bosses, and holes.



**Figure 4-23. The gearbox housing cover**

Figure 4-24 shows a simplified model of the part in which a sample of non-precision small ribs, holes, and bosses are shown.



**Figure 4-24. Simplified model of the gearbox housing cover**

Apply two default profile tolerance statements to control all non-precision aspects of this part. The first statement is to control the large scale geometry of the part. The second profile statement is to control the small feature sizes.

2. Add default tolerances to the drawing of the endcap part shown in Figure 1-32.
3. Add default tolerances to the drawing of the turning support part shown in Figure 1-33.
4. Add default tolerances to the drawing of the transmission shaft part shown in Figure 1-34.
5. Add default tolerances to the drawing of the flange part shown in Figure 1-35.

# Chapter -5

## Tolerance Design for Unconstrained Fits Between Two Parts Part-I

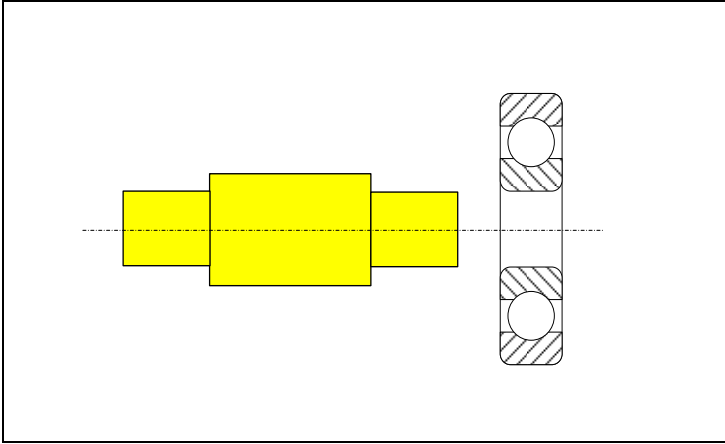
### 5.1. Overview

Unconstrained fits are the most critical and also the most precision fits in a machine assembly. In an unconstrained fit, one part is sufficiently free to align or center itself relative to a mating part. The most common unconstrained fits involve bearings. For example, a ball bearing bore must typically have a tight fit with a rotating shaft. Size precision, in the case of ball bearing fits, is so critical that often ground shafting must be used. Another example of an unconstrained fit is the fit of a plain bearing to a bearing housing. Such a fit must provide a light interference fit, which also requires precise size control.

The size control of unconstrained fits is so critical and the tolerances are so small that a standard has been developed just for the specification of precision sizes. This standard, known as ANSI B4.2 Limits and Fits Standard, will be presented in the next chapter. This chapter presents some of the concepts regarding fits that also apply to more general cases of orientation-constrained fits and location-constrained fits to be presented in later chapters. The application of the maximum material condition symbol  $\textcircled{M}$  is also presented in this chapter. In this and the next four chapters we will only discuss fits between two parts. Fits involving multiple parts will be presented in Chapter-10.

### 5.2. Unconstrained fits versus constrained fits

Unconstrained fits between two parts occur when there are no constraining surfaces limiting the orientation or the location of fitting features. In other words, one feature or part is free to assume any position or orientation in space needed to align or center itself with a mating feature. An example is the fit between the handle of a hammer and the hammer head. A common engineering application of this kind of fit is between a bearing bore and a shaft. This situation is shown in Figure 5-1.



**Figure 5-1. An example of an unconstrained fit**

The following applications usually require a precision unconstrained fit between the main fitting features:

- Rolling-element bearing bores and shafts
- Rolling-element bearing outer races and housing holes
- Plain bearings and shafts
- Plain or flanged bearing outer diameters and housing holes
- Gears and other shaft components (couplings, collars, pulleys) and shafts
- Dowel pins and pin holes
- Keys and keyways
- Press fit or shrink fit features

In unconstrained fits, the fit tightness or looseness is usually of critical functional importance and must be controlled with high precision.

Before exploring unconstrained fits, it is important to be able to recognize various appearances of constrained fits. Constrained fits between two features also require the features to fit together but in the case of constrained fits, the two features are required to maintain a certain orientation, or position, with respect to each other. Figure 5-2 shows an example of an orientation-constrained fit between two parts.

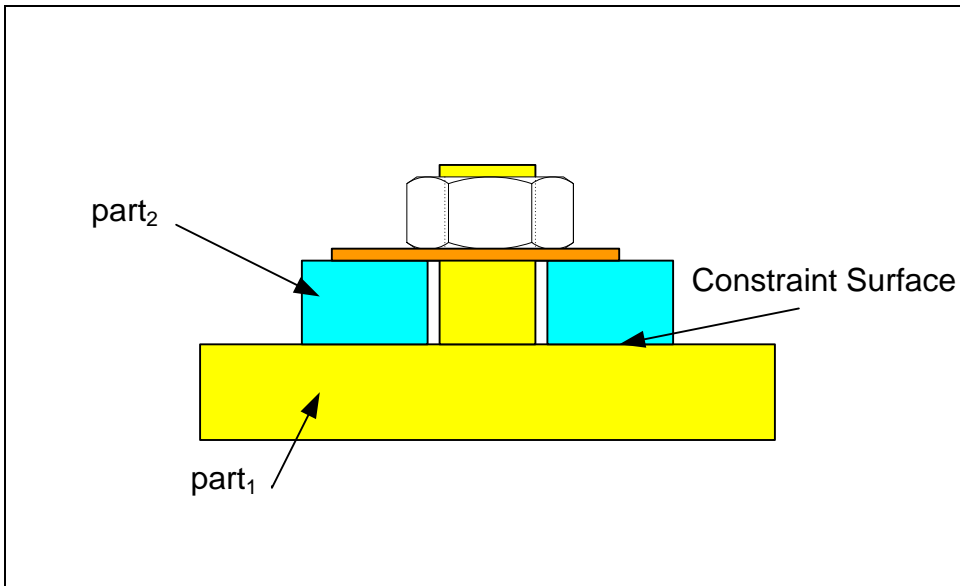


Figure 5-2. An example of an orientation-constrained fit between two features

In this example, the design intent is for the two features in part<sub>1</sub> and part<sub>2</sub> to fit together while they are constrained to maintain a specific relative orientation. The relative orientation is forced by the contact surfaces. If one or both fit features are not perpendicular to their contact surfaces with sufficient accuracy, the features may not fit together properly even though their sizes may allow free fit. Figure 5-3 shows another constrained fit in which the features are not only orientation-constrained by the mounting surfaces but also location-constrained by the locating edges.

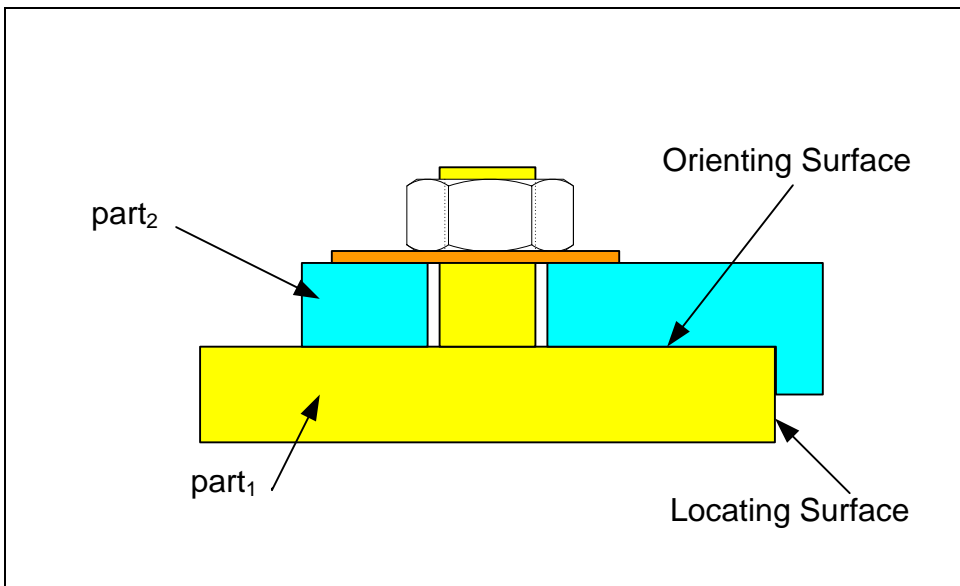
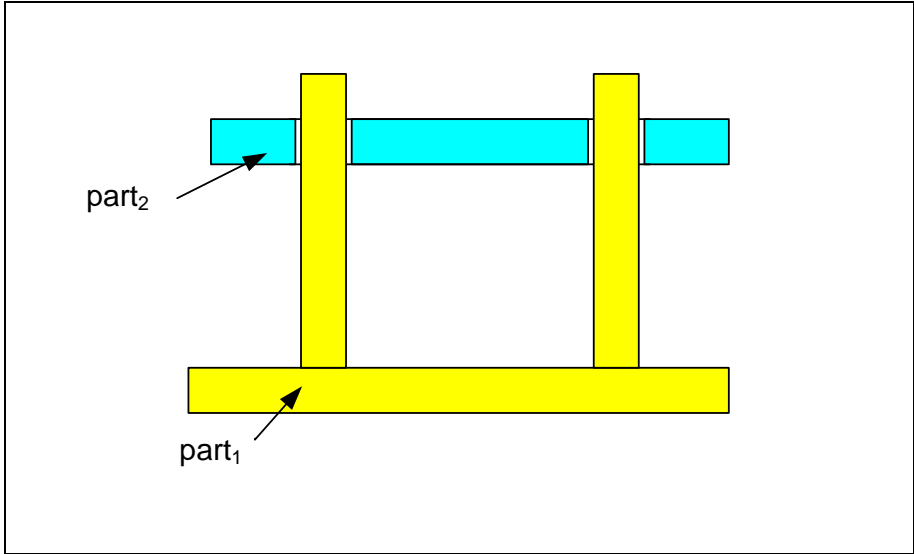


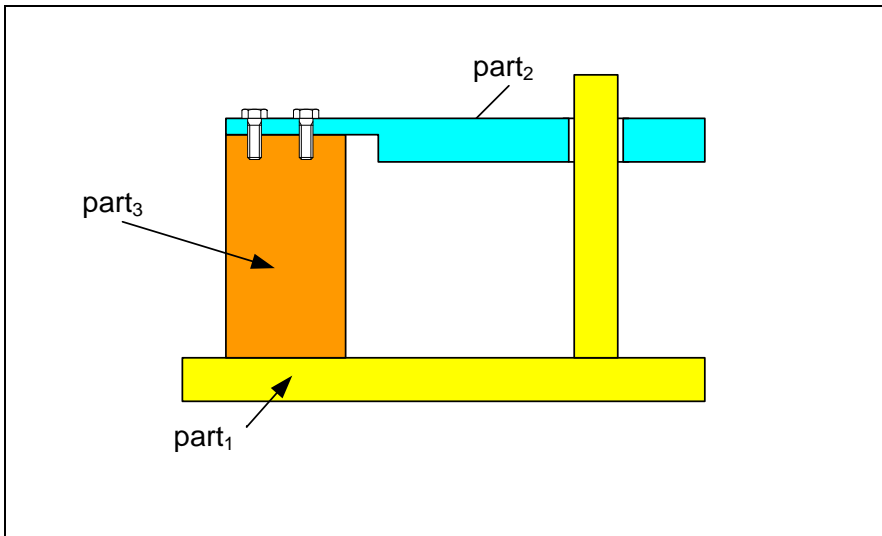
Figure 5-3. An example of an orientation and location constrained fit between two features

Another common location-constrained fit is the fit between two feature patterns or when multiple features fit each other simultaneously. In a feature pattern, shown in Figure 5-4, the fit features are constrained by each other and no single feature is completely free to align itself independent of the other features. On part<sub>1</sub>, for example, the location of one fit feature is constrained by another feature that fits simultaneously.



**Figure 5-4. A feature pattern fit or simultaneous fit is always a constrained fit**

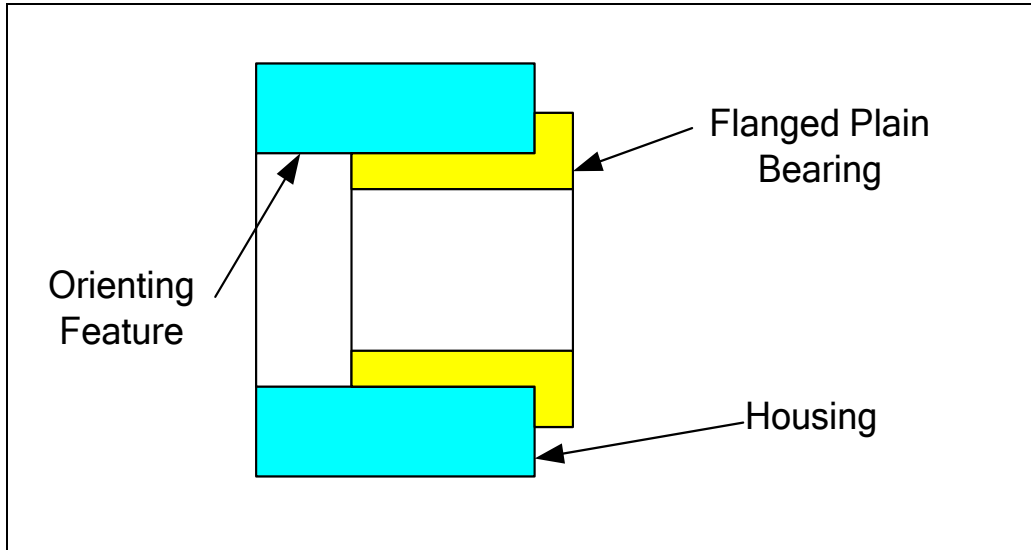
In some situations, the constraint between two fit features is caused by a third part as shown in Figure 5-5.



**Figure 5-5. A constrained fit between two features caused by a third part**

The orientation and location relationship between part<sub>1</sub> and part<sub>2</sub> is constrained by part<sub>3</sub>. Multipart fits will be discussed in Chapter-10.

The determination of whether a fit is unconstrained or constrained depends on how the final assembly is going to force geometric relationships. Sometime the appearances may be deceiving. An example of an unconstrained fit that looks like a constrained fit is the light press fit of a flanged plain bearing into a housing bore as shown in Figure 5-6.

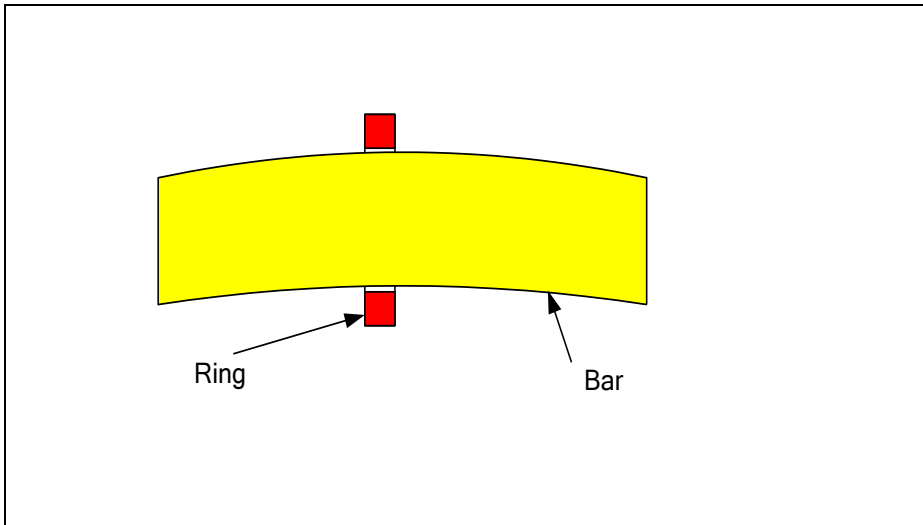


**Figure 5-6. An unconstrained fit that appears like a constrained fit**

This light press fit is an unconstrained fit as the bearing and bearing hole center themselves freely for press-fit. When the bearing is pressed in, it stops when the flange makes contact with the housing. Functionally there is no need for the planar surfaces to align perfectly. Moreover, there are no design features, such as screws, that would force the two surfaces to align. The fit features themselves orient the two parts with respect to each other, not the contacting shoulders.

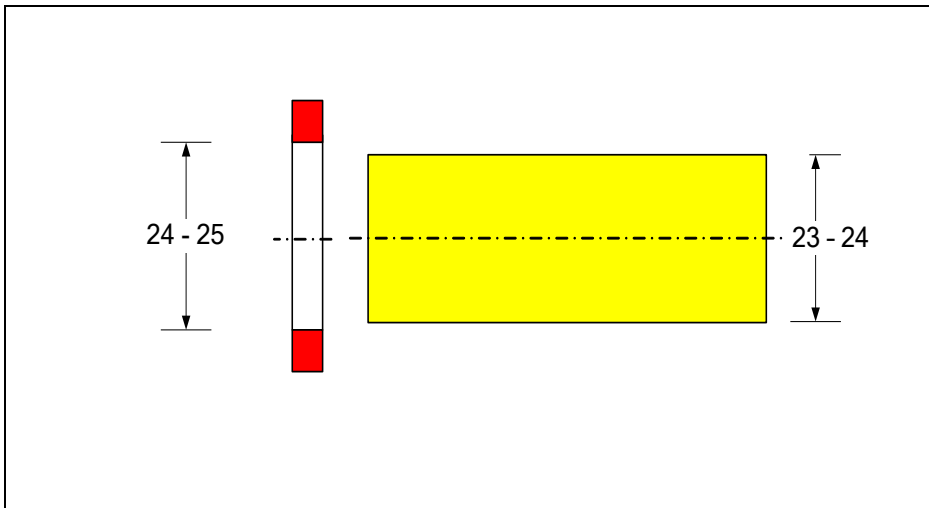
### **5.3. Fit assurance between two parts**

To study the requirements of obtaining the minimum and the maximum looseness or play in unconstrained fits, we can consider the simplest possible fit – the fit between a ring and a bar. This fit is similar to the fit between a ring and a finger. The finger does not need to be straight for the ring to fit properly provided the ring size is correct and it is not too wide. This simplest fit situation is shown in Figure 5-7.



**Figure 5-7. Fit between a ring and a bar**

To assure fit, the ring must be larger than the bar at each cross-section of the bar. The design engineer can control the cross-sectional size of a feature through size limits or size tolerance. For example, the size limits shown in Figure 5-8 assure a clearance fit.



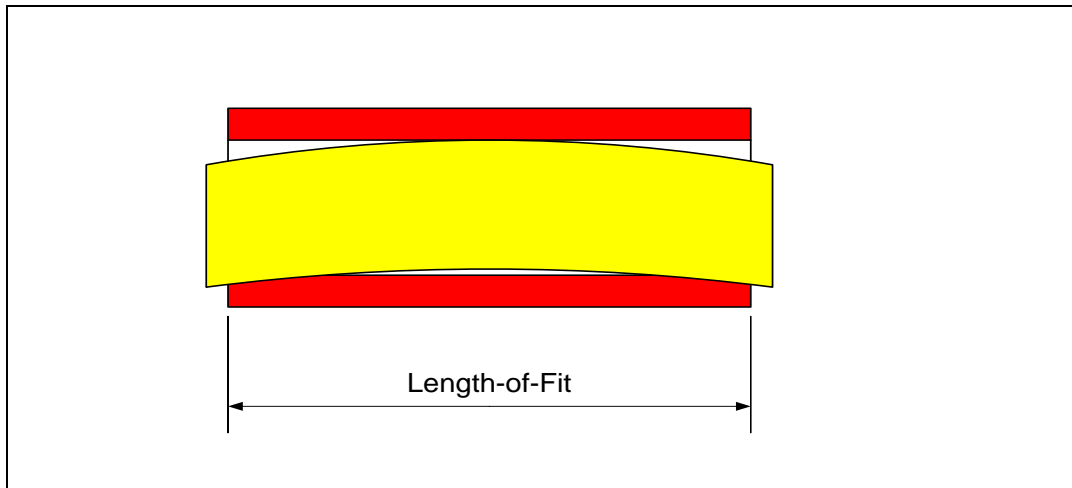
**Figure 5-8. Size limits assuring clearance fit**

The minimum possible play in this fit corresponds to the largest (bulkiest) bar of cross-section 24 mm, mating with the smallest ring of size 24 mm (also bulkiest). If a bar happens to be manufactured at its bulkiest limit of size which corresponds to its maximum size, it is said to be made at its *maximum material condition* or at MMC. The special symbol  $\text{\textcircled{M}}$  is used to indicate a feature at its maximum material condition. If the bar is made at its skinniest limit of size which corresponds to its minimum size, it is said to be made at its *least material condition* or at LMC. The special symbol  $\text{\textcircled{L}}$  is used to indicate a feature at its least material condition. In the example above, the size of the bar

at its MMC is 24 mm and the size of the bar at its LMC is 23 mm. For the hole feature the situation is reversed; the smallest hole has the most material and its MMC size corresponds to 24 mm. The LMC size of the hole corresponds to the largest hole size, which is 25 mm.

In the case of the features in Figure 5-8, the minimum possible play is zero and occurs when a 24 mm bar fits a 24 mm hole – both at their maximum material conditions. The maximum possible play occurs when the two features are made at their LMC limits. In this case the maximum play occurs when a 23 mm rod fits a 25 mm hole. The maximum possible play is 2 mm.

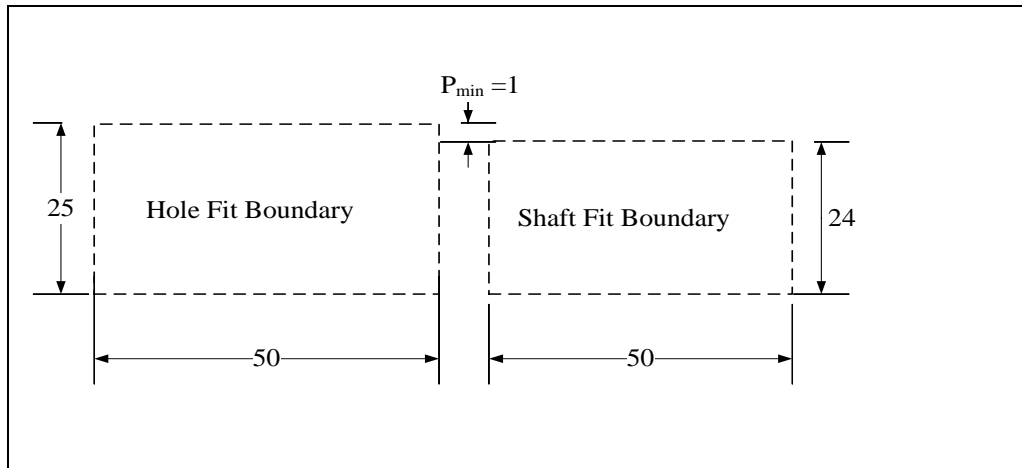
In most practical unconstrained fits, the length of fit is longer than a thin ring and the control of cross-sectional size alone is not sufficient to assure fit. Consider the example in Figure 5-9.



**Figure 5-9.** Cross-sectional size limits do not assure fit when the length-of-fit is long

The cross-sectional sizes of the two features are the same as the cross-sectional sizes of the bar and the ring shown in Figure 5-7 but the two features no longer fit because the ring is no longer thin. The length-of-fit is the length of the hole feature. The designer's problem is as before – how to assure fit with a desired minimum play while controlling the maximum possible play from becoming excessive.

To assure a minimum play of  $P_{min}$  between two mating features, the design engineer can define two conceptual cylindrical surfaces, one for the shaft feature and one for the hole feature. The size difference between the shaft and hole conceptual cylinders would be  $P_{min}$  as shown in Figure 5-10. In this case  $P_{min}$  is 1 mm. These conceptual cylinders will be called *fit boundaries* in this book. The fit boundary lengths of both features are equal to the length-of-fit in this example.

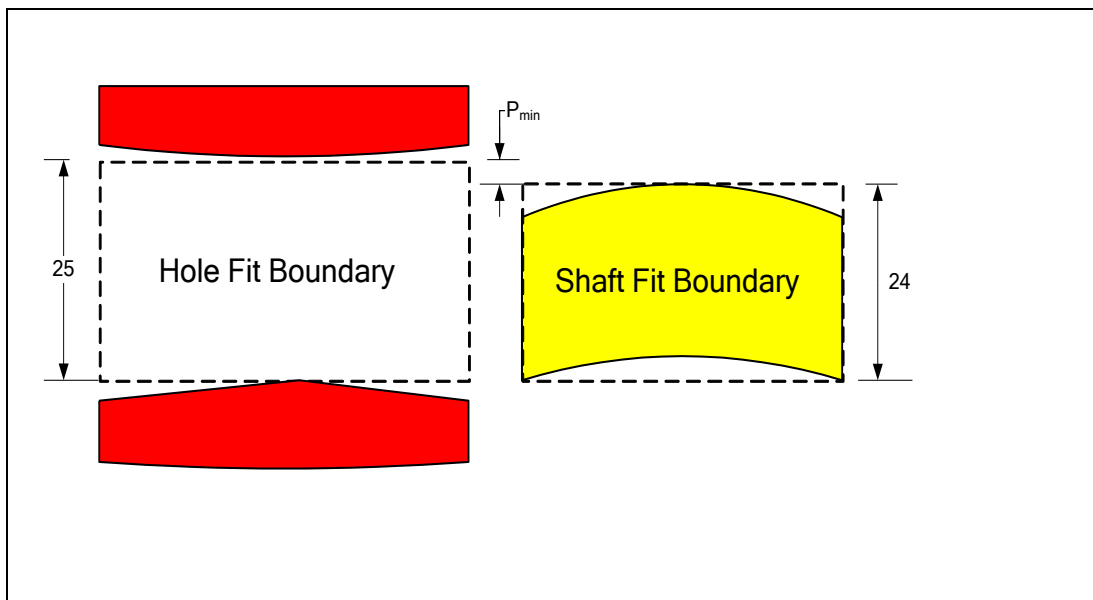


**Figure 5-10.** Theoretical hole and shaft boundaries for mating features to ensure a 1 mm gap

To ensure a minimum play of at least  $P_{min} = 1$  mm between the two features after they fit together, any length-of-fit portion of the shaft must fit inside the shaft fit boundary while the hole must fit outside the hole fit boundary. Therefore, the designer should send the following tolerancing instructions to manufacturing:

- *Make the shaft feature such that every 50-mm length of it would fit inside a cylindrical zone of size 24 mm, and make the hole feature such that it would fit outside a cylindrical zone of size 25 mm.*

If manufacturing carries out the production according to instructions, the design objective is achieved. Figure 5-11 shows one example of two actual features that fit together and have a minimum play of a little more than 1 mm after assembly.



**Figure 5-11.** An example of two features conforming to their fit boundary requirements

Fit boundaries are known as *virtual boundaries* in the GDT standard. Fit boundaries are theoretically perfect cylinders for cylindrical features, or a pair of parallel-planes for width features. It should be clear that the fit boundary controls the combined effect of cross-sectional size and feature axis straightness. For the shaft, the combination of the cross-sectional size and axis bending must be less than 24 mm. Similarly for the hole, the combination of cross-section size and axis bending must leave an opening larger than 25 mm. For the fit of width features, the center plane flatness must be used instead of the axis straightness.

The question is how the design engineer should efficiently communicate the fit boundary requirement to the manufacturing and inspection personnel. For someone who does not know the GDT symbols, the following tolerance statement note captures the fit boundary requirement for the shaft and communicates the functional needs of the design:

➤ *Make the shaft such that it would fit inside a 24-mm hole.*

This instruction is fine for inspection personnel as the final product is available and can be checked against a gage the size of the fit boundary. During manufacturing, however, the given instruction is difficult to use. An alternative form in terms of feature cross-sectional sizes and bending of axis is more helpful in manufacturing because these deviations can be quantitatively measured separately. We can use the following equivalent description of the fit boundary:

➤ *Make the shaft such that its maximum cross-sectional size would not exceed 24 mm. If the cross-sectional size is 24-mm, the feature must be perfectly straight. When the cross-sectional size is smaller than 24-mm, the shaft can bend by the difference between the actual size and the MMC size of 24 mm.*

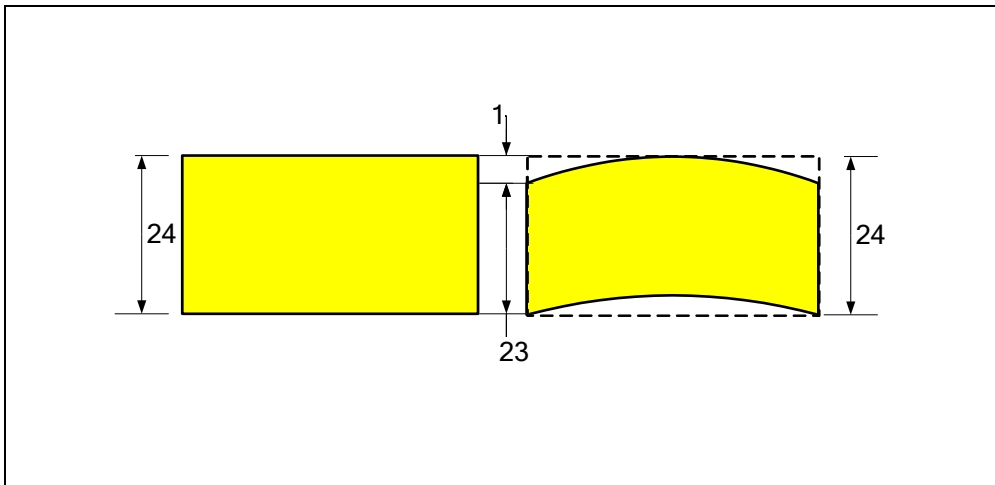
For example, the axis of a 23 mm shaft can bend 1 mm and still fit the 24 mm boundary. Even a 20 mm shaft can bend 4 mm and still pass the tolerance statement. Obviously, the above tolerance statement sets no limit on how small the shaft diameter can be. Another statement would be required to limit the maximum fit play by excluding shafts that are too small.

Specifying the LMC size is the proper method of controlling the minimum shaft size and the resulting maximum fit play. For example, we can use 23-mm for the smallest acceptable size of the shaft (or its LMC size). Adding this minimum size limit and also abbreviating the text of the previous instruction, the new tolerance requirement should have the following two parts:

➤ *Make the shaft such that its cross-sectional size is between 23 and 24 mm*  
➤ *If the cross-sectional size is 24-mm (at MMC), the shaft must be perfectly straight.*

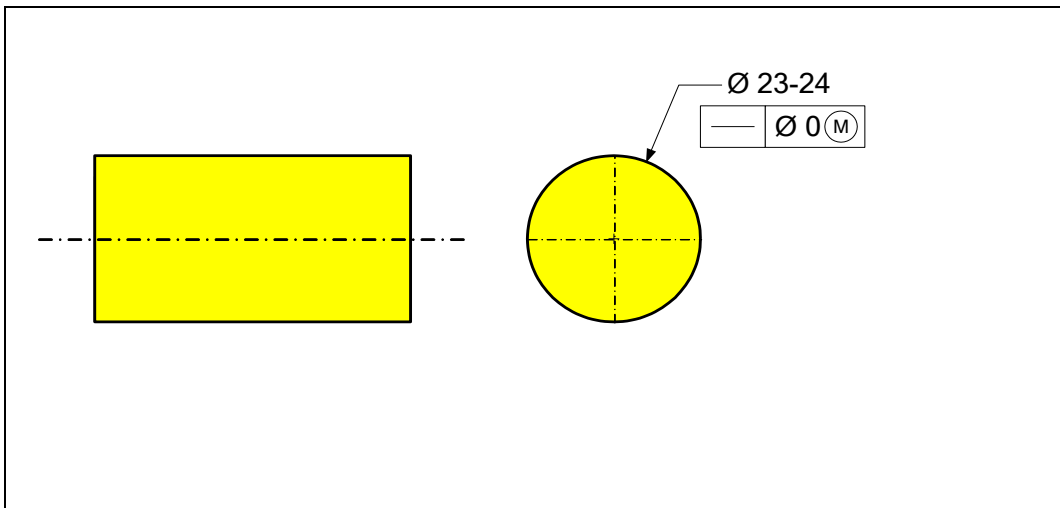
The two statements imply that what is required is a fit boundary size of 24 mm and the minimum cross-sectional size is to be 23 mm. Two extreme shapes of the shaft that

would be acceptable based on the tolerance description above are shown in Figure 5-12. The fit boundary for the shaft simply acts like a tube – any shape that fits inside the tube passes the fit boundary requirement.



**Figure 5-12. Acceptable feature at MMC (left) and at LMC (right) with maximum bending**

The design engineer must now translate the tolerance requirements stated above in text form into GDT standard symbols and place those symbols on the drawing. Figure 5-13 shows the way it must be indicated on the drawing.



**Figure 5-13. Defining a 24 mm fit boundary using the GDT standard format**

The geometric tolerance statement indicates that if the feature is made at its maximum material condition of 24 mm, then it has to be perfectly straight. The fit boundary of the shaft in this case is equal to its MMC size. If appropriate, we can make the fit boundary larger than the MMC size of the shaft by using a non-zero straightness for tolerance

value. For example, to define a 25 mm fit boundary for a shaft with 23-24 mm size limits, we must specify a 1 mm straightness tolerance at MMC as shown in Figure 5-14.

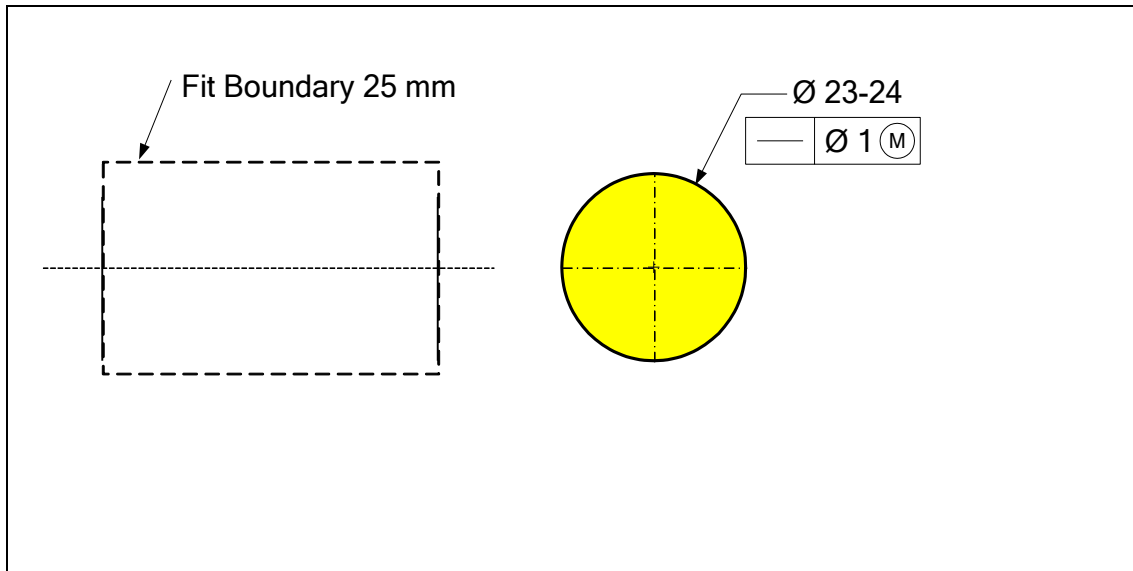
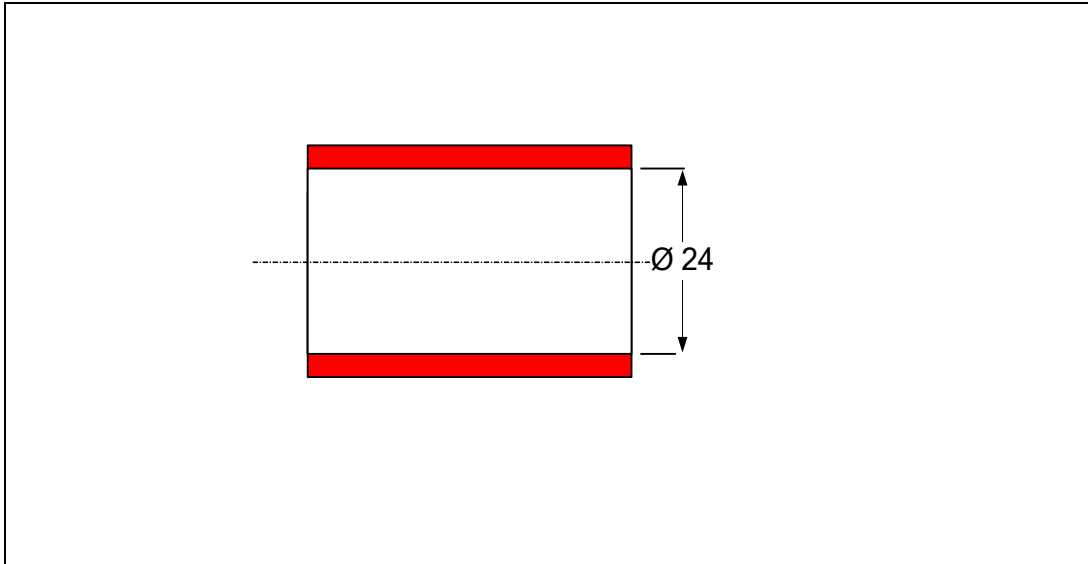


Figure 5-14. Defining a 25 mm fit boundary using the GDT standard format

In this case, a 24-mm shaft is allowed to bend 1 mm while a 23-mm shaft can bend 2 mm.

#### 5.4. Theoretical gages for tolerance statements that use the $\textcircled{M}$ symbol

For tolerance statements that use  $\textcircled{M}$  next to the tolerance value, the theoretical gage has the size and shape of the fit boundary defined by the tolerance statement. For a shaft, the acceptance zone is defined as a tube, and for a hole, the acceptance zone is defined as a bar. Figure 5-15 shows the theoretical gage for the tolerance specification in Figure 5-13 where the MMC size is 24 mm and straightness tolerance is zero at MMC. The tube gage must be at least the length of the bar.



**Figure 5-15. Theoretical gage for straightness specification of Figure 5-13**

This theoretical gage can be physically made as a tube and physical gaging amounts to checking to determine if the manufactured bar fits inside the tube. This kind of physical gaging is feasible with all tolerance statements that use  $\textcircled{M}$  because all  $\textcircled{M}$  related specifications are about feature fit and fits are easy to test physically.

## 5.5. Fit formula

We can summarize the requirements for a clearance fit as a formula and also develop a formula for the maximum possible play in a fit. The following nomenclature will be used throughout the rest of this book. Size in the following statements refers to a diameter or a width dimension.

- $FB_H$ : The size of the fit boundary of an internal feature (a hole or a slot)
- $FB_F$ : The size of the fit boundary of an external feature (a shaft or a rail)
- $H_{min}$ : The MMC size of a hole or slot feature (minimum size)
- $F_{max}$ : The MMC size of a shaft or a rail feature (maximum size).
- $H_{max}$ : The LMC size of a hole or slot feature (maximum size)
- $F_{min}$ : The LMC size of a shaft or a rail feature (minimum size)
- $T_H, T_F$ : The specified geometric tolerance values at MMC for hole and shaft features
- $t_H, t_F$ : The size tolerance values for hole and shaft features. The size tolerance is the total tolerance range on a size dimension (difference between MMC and LMC dimensions)
- $P_{max}$ : The maximum possible play in clearance fits
- $P_{min}$ : The minimum assured play in clearance fits

To develop the  $P_{min}$  and  $P_{max}$  formulas for a fit, consider the hole and shaft fit boundaries in Figure 5-16.

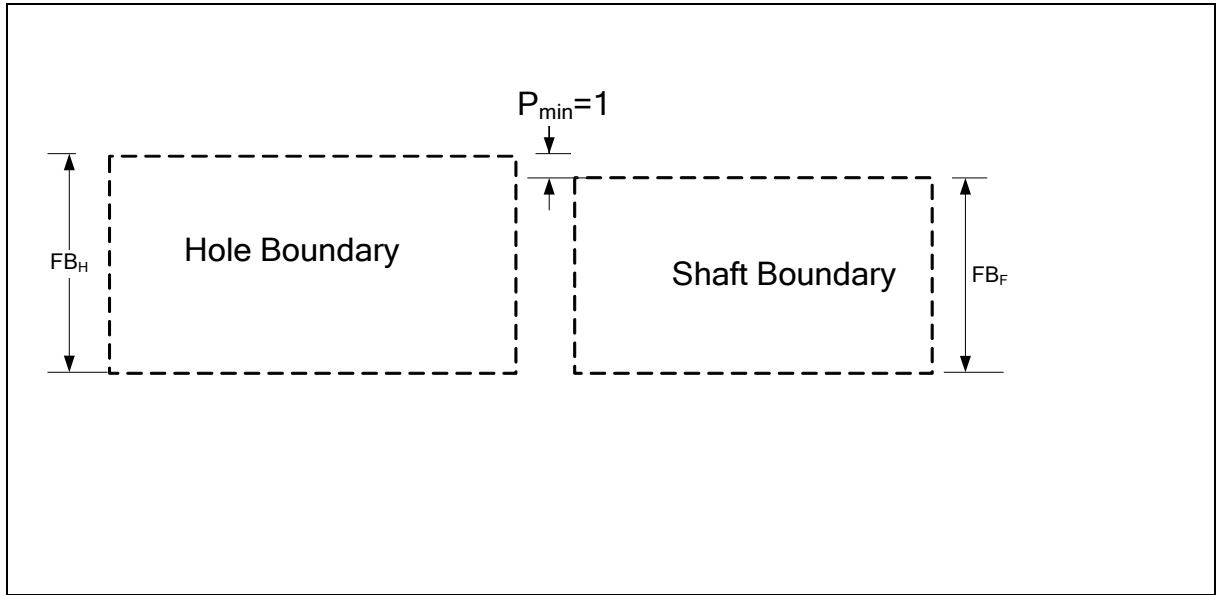


Figure 5-16. The difference in fit boundaries defines the minimum assured play

The minimum assured play in a clearance fit is the difference between the two feature's fit boundaries

$$P_{min} = FB_H - FB_F \quad [1]$$

Defining the fit boundaries in terms of MMC size and geometric tolerances

$$P_{min} = (H_{min} - T_H) - (F_{max} + T_F) \quad [2]$$

Or

$$P_{min} = (H_{min} - F_{max}) - (T_H + T_F) \quad [3]$$

Eq.[3] is the minimum play formula for a clearance fit. Once the tolerance values are specified, we can set up  $(H_{min} - F_{max})$  to be equal to the sum of tolerances  $(T_H + T_F)$  for a zero clearance fit. Setting the minimum play to zero would set the sizes of the fit boundaries equal to each other. Setting  $P_{min} \geq 0$  and solving for the geometric tolerances, we get

$$(H_{min} - T_H) - (F_{max} + T_F) \geq 0 \quad [4]$$

Or

$$T_H + T_F \leq H_{min} - F_{max} \quad [5]$$

Eq. [5] indicates the condition for a clearance fit and is called the *fit formula*.

The maximum play in a clearance fit occurs when the two fit features are made at their least material condition and are perfectly straight. The maximum play formula based on LMC sizes is

$$P_{max} = H_{max} - F_{min} \quad [6]$$

where  $H_{max}$  and  $F_{min}$  are the LMC hole and shaft feature sizes. Eq.[6] is the *maximum play formula*. By substituting  $H_{max} = H_{min} + t_H$  and  $F_{min} = F_{max} - t_F$  into Eq.[6] and

considering Eq.[3], we can write Eq.[6] in terms of tolerances of size and geometric tolerances as

$$P_{max} = t_H + t_F + T_H + T_F + P_{min} \quad [7]$$

The maximum possible play is the sum of all tolerances (geometric and size) plus any assured minimum play in the fit. If the tolerances are set up for a fit with a minimum play of zero, then the maximum play is just the sum of all tolerance values.

### Example-1

The MMC sizes of a hole and shaft are  $H_{min}=12$  mm and  $F_{max}=10$  mm respectively. Straightness tolerance values are specified at MMC.

- Determine the geometric tolerances that assure a fit with a minimum play of zero. What are the sizes of the fit boundaries?
- Determine the geometric tolerances to have a fit with a minimum assured play of 1 mm. What are the sizes of the fit boundaries?
- Determine the maximum possible play in the fit for case (b) when size tolerances are 0.5 mm ( $H_{max}=12.5$  mm and  $F_{min}=9.5$  mm).

**Part-a)** Using the fit formula,

$$T_H + T_F \leq H_{min} - F_{max}$$

or

$$T_H + T_F \leq 12 - 10 = 2 \text{ mm}$$

If the geometric tolerances (straightness specifications) are selected to be equal ( $T_H = T_F$ ) then we must have

$$T_F = T_H \leq 1 \text{ mm}$$

The straightness tolerance values define the size of the fit boundary for the shaft to be equal to  $10+1=11$  mm. The fit boundary of the hole is also  $12-1=11$  mm, guaranteeing a clearance fit with a minimum play of zero.

**Part b)** In order to have at least a minimum play of  $P_{min}$  in the clearance fit, we must add a  $P_{min}$  to the hole fit boundary, or subtract a  $P_{min}$  from the shaft fit boundary. The resulting tolerance relationship to assure a minimum play of  $P_{min}$  is

$$T_H + T_F \leq H_{min} - F_{max} - P_{min}$$

For  $H_{min}=12$ ,  $F_{max}=10$ , and a  $P_{min}$  of 1 mm, we must have

$$T_H + T_F \leq 1$$

If the geometric tolerances are selected to be equal ( $T_H = T_F$ ) then we must have

$$T_H \leq 0.5 \text{ mm}$$

$$T_F \leq 0.5 \text{ mm}$$

These straightness tolerance values define the size of the fit boundary for the shaft to be equal to  $10+0.5=10.5$  mm. The fit boundary of the hole is  $12-0.5=11.5$  mm guaranteeing at least a 1 mm clearance fit.

**Part-c)** The maximum possible play for the case (b) solution can be as large as

$$P_{max} = H_{max} - F_{min} = 3 \text{ mm}$$

Using the tolerance values formulation, we get the same result

$$P_{max} = t_H + t_F + T_H + T_F + P_{min}$$

$$P_{max} = 0.5 + 0.5 + 0.5 + 0.5 + 1 = 3 \text{ mm}$$

In most unconstrained fits such as fit of bearings or gear hubs etc., the minimum and maximum plays and interferences are both critical to the proper function of the fit. For constrained fits it is usually best to set  $P_{min}=0$ . This choice assures free assembly and results in the smallest play in the fit.

## 5.6. Default form control implied by limits of size

In the GDT standard, there is more geometry control behind the limits of size than just the control of cross-sectional size limits. In the absence of other specifications the limits of size for regular features-of-size also control the form of such features. The default form control that automatically applies to a cylindrical feature is a zero straightness tolerance at MMC. For example, when a shaft with size limits of 23-24 mm is indicated on a drawing without any explicit straightness specification, the feature is also required to have a 24-mm fit boundary. Figure 5-17 shows the implied meaning of this default requirement.

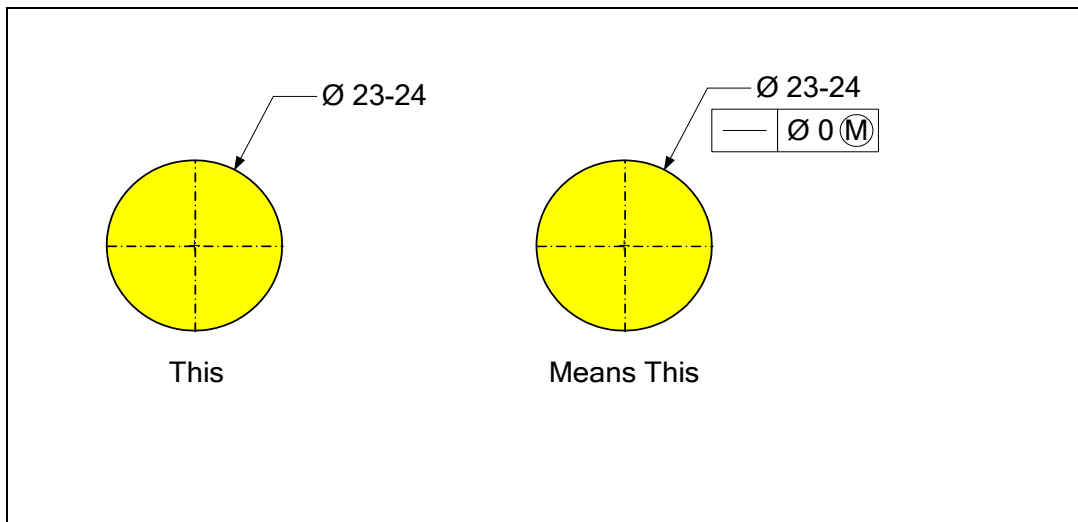


Figure 5-17. The default form control of GDT standard

The default form control of the GDT standard is known as *Rule#1*. To override Rule#1, a straightness tolerance can be explicitly applied to the feature with a desired tolerance value. When form control is not needed at all, the independency symbol can be used with the size limits as shown in Figure 5-18.

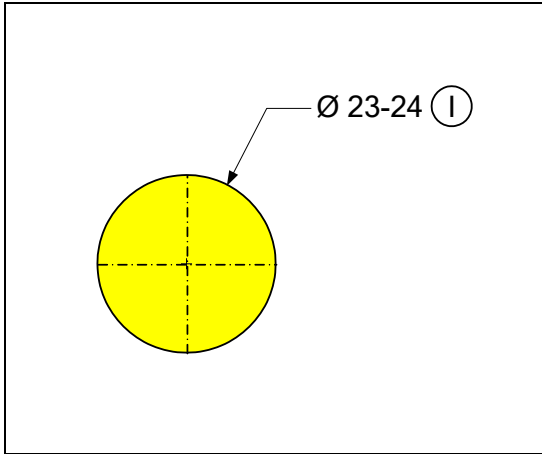


Figure 5-18. The use of independency symbol

The application of the independency symbol will be presented later in an example.

### 5.7. Use of zero geometric tolerance at MMC

Fit boundaries are defined by adding or subtracting a geometric tolerance to the MMC size of a feature. In unconstrained fits, the geometric tolerance is axis straightness for cylindrical features and center plane flatness for width features. There is an unlimited combination of MMC sizes and geometric tolerances that can define the same fit boundary, including the use of zero geometric tolerance at MMC. What factors should be considered in determining the best choice of tolerance statements? Consider an example that compares the use of zero geometric tolerance at MMC with an alternate that allows 1 mm geometric form tolerance at MMC. Figure 5-19 shows two examples that define the same fit boundary. The combined tolerances of size and straightness in both cases is 2 mm.

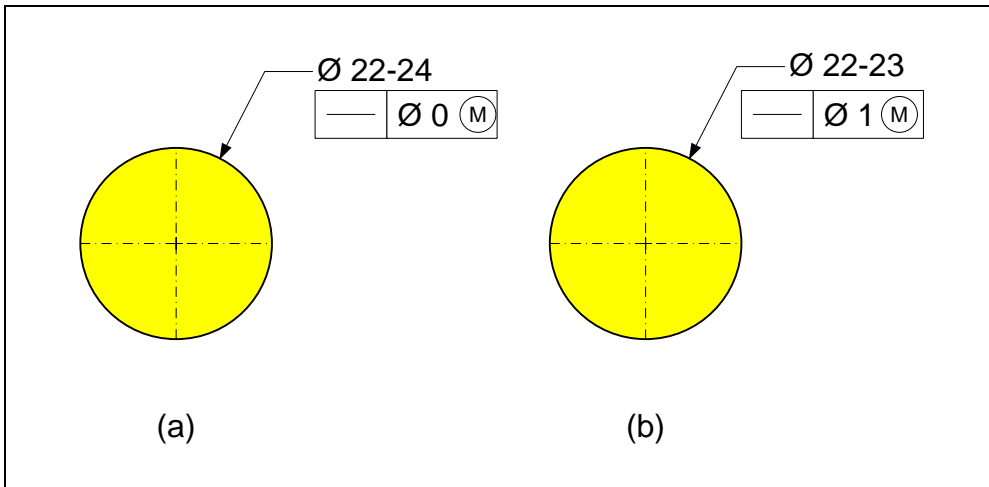


Figure 5-19. The tolerance statements define the same fit boundary for the feature

Both of these options define a fit boundary of 24mm. In addition, both specifications have a LMC size of 22 mm and therefore the maximum possible play resulting from their use in an unconstrained fit is also the same. In other words, the features that are made based on the two specifications allow the same performance in terms of fit and play in a two-part assembly.

There is, however, an important difference between the two options even for fit purposes. While size tolerance can convert into additional geometric tolerance, the GDT standard does not allow geometric tolerances to convert into additional size tolerances. Consider an actual feature with a cross-sectional size of 23.5 mm and an actual bend of 0.4 mm. The feature would fit into the 24 mm fit boundary and should be acceptable for fit. The specification (a) in Figure 5-19 accepts such a part but the specification (b) rejects the part because it exceeds the 23 mm size limit. In the above example, when the part is made to be very straight, the 1 mm allowance for straightness is not permitted to be used to widen the size limit on the MMC side. For fit purposes, the zero tolerance straightness option makes the variations in size and straightness interchangeable both ways. An actual feature made close to its LMC limit of size leaves maximum allowance for bending. Conversely, a feature made with very little bending leaves maximum allowance for size.

Applying zero tolerance at MMC is also the easiest way of indicating the fit boundary requirement as the size of the fit boundary would correspond to the specified MMC size of the feature. Zero geometric tolerances allow the design engineers to combine the size and geometric tolerance into one tolerance – a combined size tolerance. The difference between the LMC and MMC size limits becomes the sum of size and geometric tolerances applied to the feature. This provides the maximum flexibility to the manufacturing to meet the tolerance needs at minimum cost. When the manufacturing sees the wide 22-24 mm tolerance of size, they can select the best process to obtain an acceptable feature. For example, if they have a process that can hold size tolerances very well but not the bending tolerances, they can target a size just above the LMC of 22 mm. This gives them almost 2 mm of bending allowance. On the other hand, they may have a process that does not hold size tolerances very well but is accurate in keeping the feature straight. In such a case, manufacturing can target the middle of the tolerance range, such as a 23 mm size, to have maximum size allowance. The result of the above reasoning is that, whenever possible, it is best to specify zero geometric tolerance at MMC for unconstrained fit purposes. A zero straightness tolerance at MMC is often implied with standard parts. For example, a standard dowel pin with a declared maximum size of 10 mm is implied to have a 10 mm fit boundary and fit entirely inside a 10 mm hole.

The only potential drawback of zero geometric tolerances is that the features appear to be specified to have zero geometric tolerance, or perfect form. A zero-tolerance value is perceived as impossible by some manufacturing personnel. This can become a source of potential confusion. Well-trained manufacturing personnel, however, know that zero-tolerance specifications give them the most flexibility and control. Trained manufacturing personnel understand that the size limits are in fact a combined tolerance

of size and geometric tolerance. The manufacturing personnel know that they are free to divide up the combined tolerance between size and straightness any way they deem advantageous as long as the fit boundary requirement is met. If the use of zero geometric tolerance proves to be awkward in a production environment, the design engineer should specify a non-zero tolerance. Zero geometric tolerance can only be used when  $\textcircled{M}$  or  $\textcircled{L}$  symbols are used in the tolerance statement.

## 5.8. Fit formula when using zero geometric tolerancing at MMC

Using zero geometric tolerance method simplifies the fit formula by including the geometric tolerance into the size limits. We can write the fit formula

$$T_H + T_F \leq H_{min} - F_{max}$$

in the following form:

$$(H_{min} - T_H) - (F_{max} + T_F) \leq 0$$

Interpreting each term as a new limit of size and using new symbols for the two terms in parentheses, the fit formula becomes

$$H_{0min} - F_{0max} \geq 0$$

where  $H_{0min}$  is the MMC size of the hole feature when zero geometric tolerance is used. Similarly,  $F_{0max}$  is the MMC size of the shaft feature when zero geometric tolerance is used.

To convert a specification with non-zero geometric tolerance at  $\textcircled{M}$  to one with zero geometric tolerances at  $\textcircled{M}$ , we must expand the size limits by the value of the geometric tolerance on the MMC side. For example, if the hole size limits are 20-21 mm and the selected geometric tolerance is 0.5 mm, the equivalent size limits for zero geometric tolerance becomes 19.5-21.0 mm. We simply expand the hole size limits of 20-21mm on the MMC side of  $H_{min}=20$  mm by  $T_H=0.5$  mm to get  $H_{0min} = 19.5$  mm. For a shaft feature of limits 19-20 mm with a specified geometric tolerance of 0.5 mm at MMC, the size limits for zero geometric tolerance becomes 19.0-20.5 mm. Again, we expand the size limits of 19-20 mm on the MMC side of  $F_{max}=20$  mm by  $T_H=0.5$  mm to get  $F_{0max} = 20.5$  mm.  $F_{0max}$  and  $H_{0min}$  also define the sizes of fit boundaries and gages for the pin and hole features.

## 5.9. Defining a fit boundary without the $\textcircled{M}$ modifier

Fit boundaries can be defined indirectly with straightness tolerances that do not specify a modifier. This practice is necessary in cases where the feature size is to be precisely controlled for a different functional reason. Straightness tolerance statements without a modifier are said to be *regardless of feature size (RFS)*. Figure 5-20 shows an example of two specifications with equal fit boundaries. The left side statement uses the usual  $\textcircled{M}$  modifier and the right side statement uses the specification without a modifier. The fit boundaries of the shaft for MMC or RFS specifications are both 24 mm. The fit boundaries of the hole for MMC or RFS specifications are also both 24 mm. Note that unlike the  $\textcircled{M}$ -modified statement we cannot inspect the RFS tolerance statement by a fit test inside the fit boundary. The RFS statement is a direct axis control statement. The fit

boundary is just an indirect consequence of not allowing a 23 mm feature bend more than 1 mm.

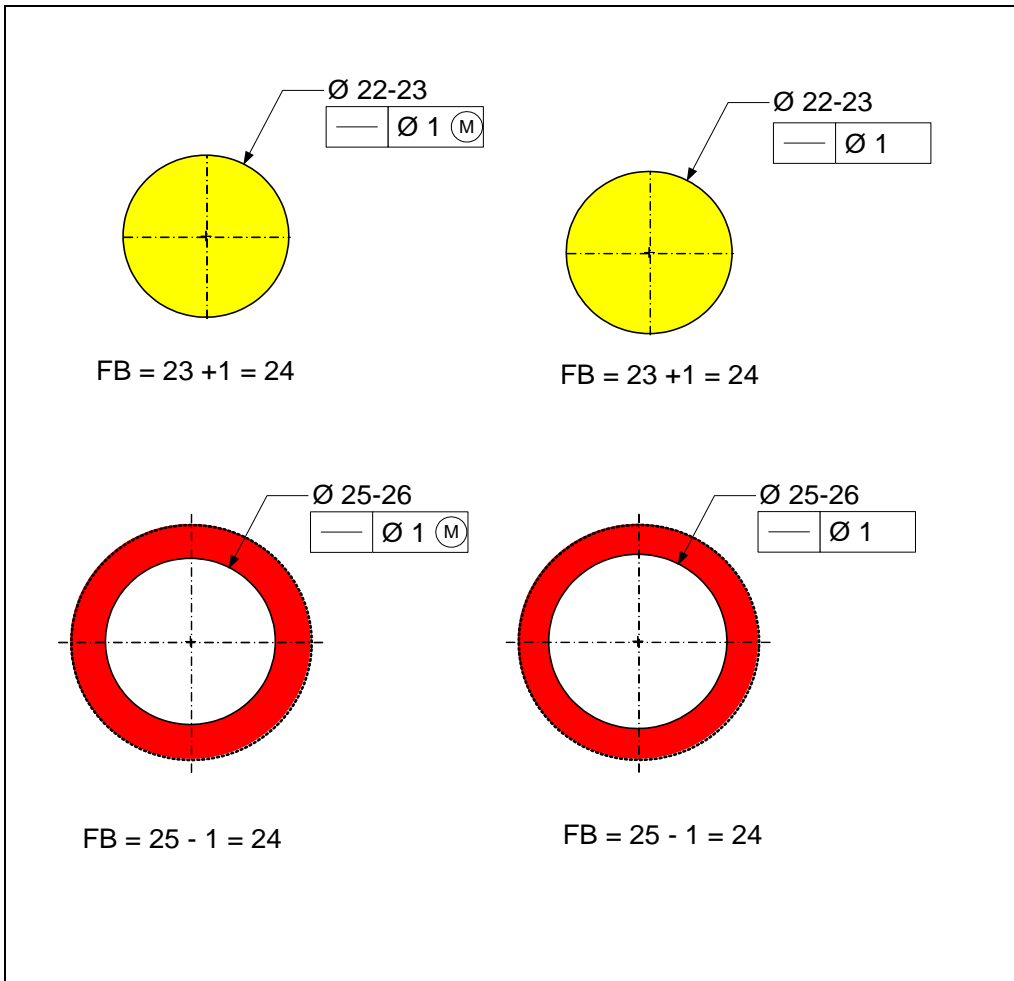


Figure 5-20. Comparing  $\textcircled{M}$  modified and RFS specifications

Since the fit boundary sizes and LMC sizes are the same for MMC or RFS specifications, the two set of specifications perform the same in a fit. The two schemes both assure fit and can lead to the same maximum play. The  $\textcircled{M}$ -modified statement is better because it adds manufacturing flexibility. The  $\textcircled{M}$ -modified statement allows the straightness to be up to 2 mm for a pin made close to its LMC size while the RFS statement allows only 1 mm regardless of the pin size.

## 5.10. A note on the use of modifiers

When applicable, the proper use of tolerance modifiers provide additional manufacturing advantages by allowing a combined tolerance to be allocated as needed. This can lead to a wider tolerance range where it is most needed. The manufacturing and inspection departments refer to this additional possible tolerance as *bonus tolerance*. Not using a

modifier, however, does not make the tolerance specification wrong – it simply would not allow this possible bonus tolerance. Even using the opposite modifier to what is appropriate does not make the tolerancing scheme wrong. What makes the tolerancing scheme wrong is missing specifications or tolerance values that are not correctly specified to assure fit. The use of a modifier, when appropriate, simply makes the tolerance specification better. The  $\text{\textcircled{M}}$  modifier is the preferred choice for two-part fits. Whatever specification is used, care must be exercised to make sure that fit is possible in all situations allowed by the specified tolerances.

### 5.11. Unconstrained fits and Rule#1

In most applications of unconstrained fits such as fit of bearings, gears, press-fits, dowel pins, or various shaft-hub fits, the use of default straightness control (Rule#1) is appropriate. In these applications the length of fit is short (compared to the fit diameter) and the use of size limits alone, which imply zero straightness tolerance at MMC, is usually a good choice.

There is a common unconstrained fit application, however, in which the default straightness control should be removed for one of the mating features. When a bearing slides on a long rod as shown in Figure 5-21, the length of fit is short but moves along the length of the rod defining a moving fit window. A similar situation occurs when a dowel pin fits a shallow hole.

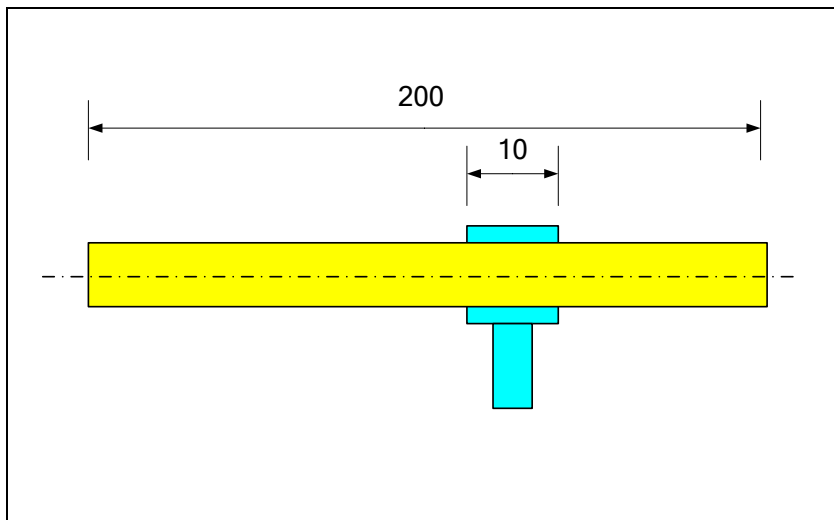
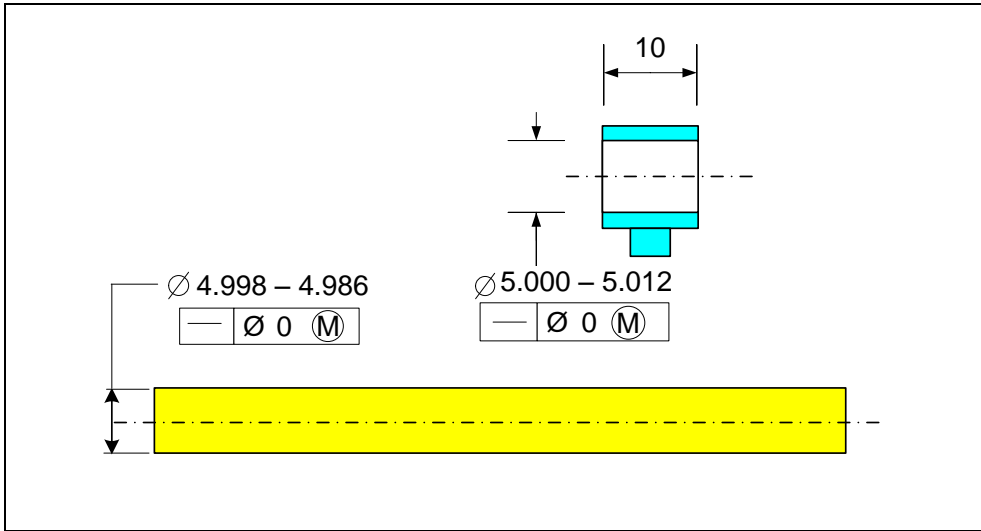


Figure 5-21. A sliding fit with a short length of overlap

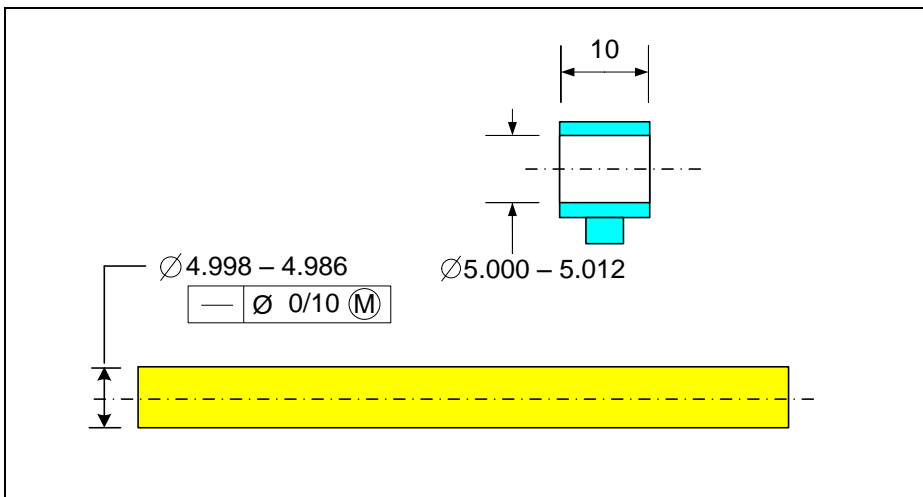
The rod's straightness for fit purposes is only needed over 10 mm lengths of the rod to achieve proper fit in sliding. If only size limits are applied to this long rod, the size limits imply perfect straightness at MMC for the entire length of the rod. In this example, if we use more realistic numbers for a rod sliding on a bearing, the recommended sliding fit dimensions would be 5.000 – 5.012 mm for the bearing hole and 4.998 – 4.986 mm for

the bar. These dimensions are indicated in Figure 5-22 along with the default straightness control they imply.



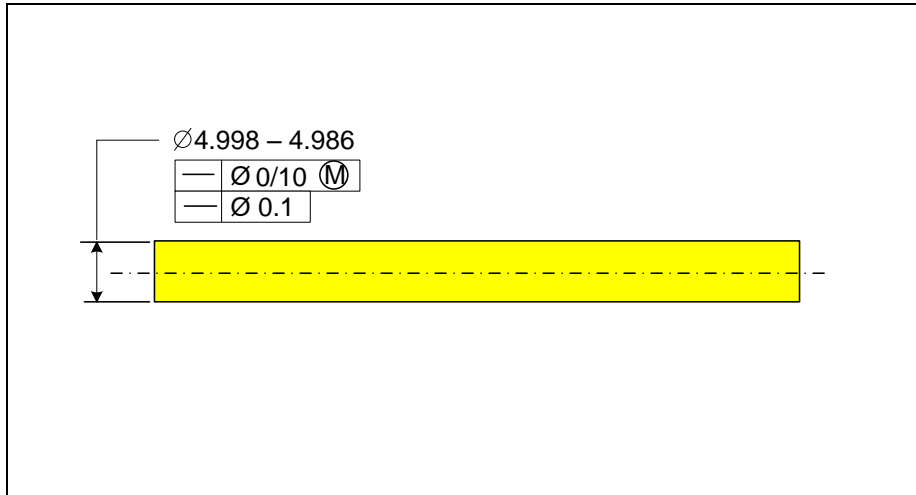
**Figure 5-22. Sliding fit dimensions along with their default form control**

The default control limits are adequate for the bearing hole but the bar default control requires the entire length of the bar to be straight with much higher precision than needed. In this example, the rod can be out of straight by only 0.012 mm over its entire length even when its cross-section is at LMC size of 4.986 mm. It is very costly to make a rod this straight over a long length and, more importantly, this level of straightness precision is not needed for proper fit and sliding action of the mechanism. The correct specification should only require zero tolerance at MMC over all 10 mm lengths of the bar. Figure 5-23 indicates how to apply this specification.



**Figure 5-23. Proper specification type when a bearing slides on a rod**

Note that this specification allows a smooth sliding fit but does not place a direct limit on the total bending of the bar. An additional straightness control specification should be added to limit the total bending of the entire bar. To place an additional constraint to limit the total amount of rod bending, the specification format shown in Figure 5-24 can be used.



**Figure 5-24. The upper specification assures sliding fit while the lower specification directly controls the overall bending of the bar**

Even if the original per length statement may control the total bending of the rod to be less than the overall total bending specification, it is important to apply an additional straightness limit. The reason is that the direct specification of the total straightness control leaves no doubt as to what is required. This is the better strategy to communicate design intent to other designers. In this case the design intent is well communicated to whoever is going to read the print. The intent is that there is a precise sliding fit on this bar over a bearing length of 10 mm, and the overall bar is to be straight for other functional reasons.

## 5.12. Unconstrained interference fits

The fit formula presented earlier applies to clearance fits where the features are intended to be assembled without force. In all situations where random assembly is required, the fit boundary of the shaft (external) feature must be specified to be smaller than or equal to the fit boundary of the hole (internal feature). If there is an overlap between the fit boundaries, there is a risk of features not assembling freely. In all intentional interference fits, however, the interference is functionally important and the designer wants to have a guaranteed minimum interference. Interference fits are always unconstrained fits. The maximum interference is dictated by the MMC sizes of the fitting features. The minimum interferences occur when features are at their LMC states.

In Figure 5-25, the minimum assured interference is 0.1 mm when both features are at LMC, and the maximum interference is 0.3 mm when both features are at MMC. For

metallic parts these interferences are very large and unattainable; the larger numbers are used here to convey the concepts. More realistic interference values will be presented in the next chapter where the standards of limits and fits are introduced.

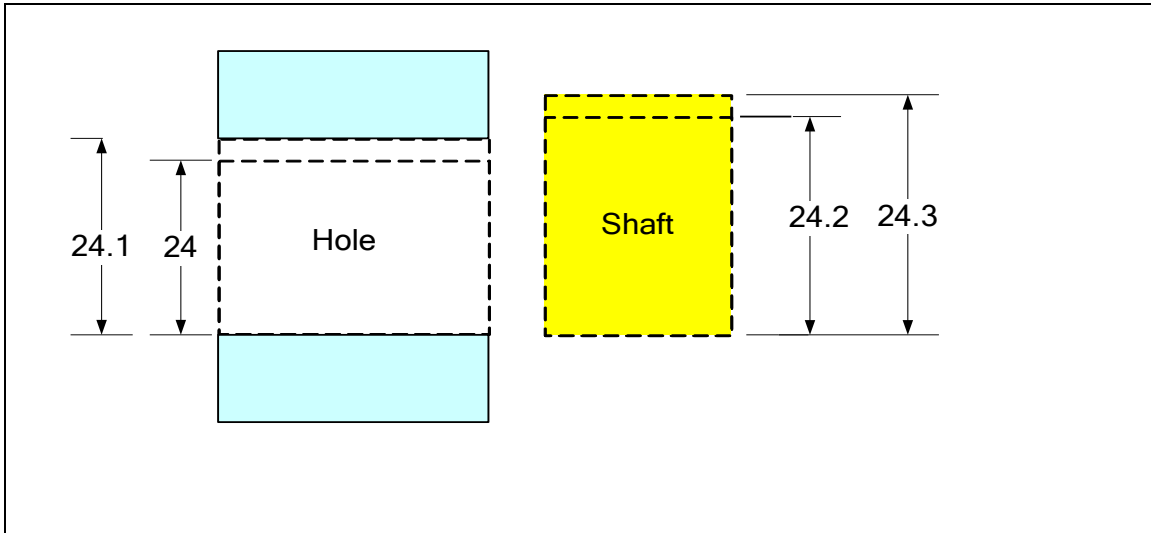


Figure 5-25. An example of interference fit

For interference fits, the same fit formulas apply except that play values become negative. In the following formula,  $P_{min}$  represents the maximum interference.

$$P_{min} = H_{min} - F_{max}$$

And  $P_{max}$  represents the minimum interference of

$$P_{max} = H_{max} - F_{min}$$

Note that these formulas ignore the possible contribution of straightness tolerance to the resulting interferences. The reason is that in interference fits the shaft is guided through the hole by force. Only the cross-section sizes are important. Even if the shaft is not straight, it would deform elastically (or plastically) to take the shape of the hole.

### Exercise Problems

1. Consider the pin shown in Figure 5-26.

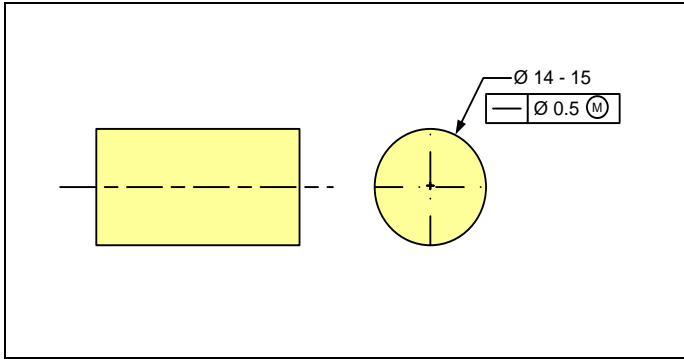


Figure 5-26. A pin with size and straightness tolerance specifications

Determine:

- The MMC and LMC sizes of the shaft
- The size of the shaft's fit boundary
- The amount of bending allowed when the feature is 14.6 mm
- The equivalent size limits for fit when the straightness tolerance is zero

2. Consider the hole feature shown in Figure 5-27.

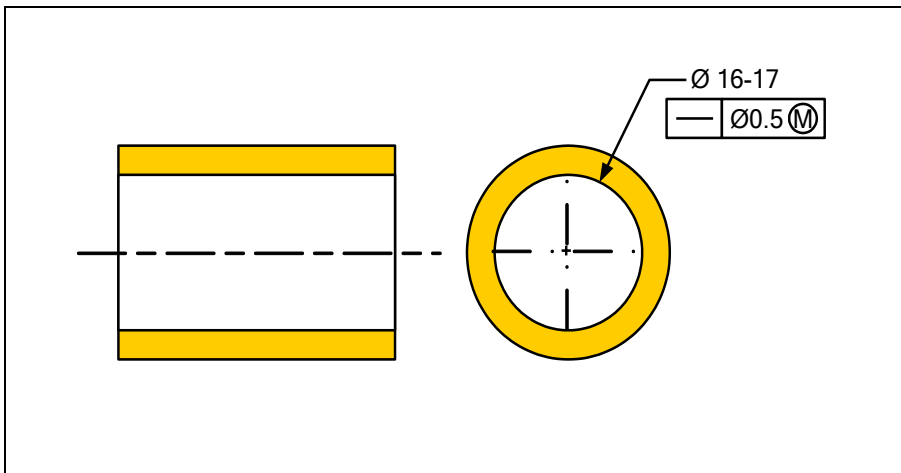


Figure 5-27. A hole feature with size and straightness tolerance

Determine:

- The MMC and LMC sizes of the hole
- The size of the hole's fit boundary
- The amount of bending allowed when the feature is made at 16.3 mm
- The equivalent size limits for fit when the straightness tolerance is zero
- When this part is fit to the shaft in Problem-1, what is the minimum and maximum possible play in the fit

3. A rectangular key is to fit a keyway as shown in Figure 5-28. The key is desired to have an unconstrained fit to the keyway.

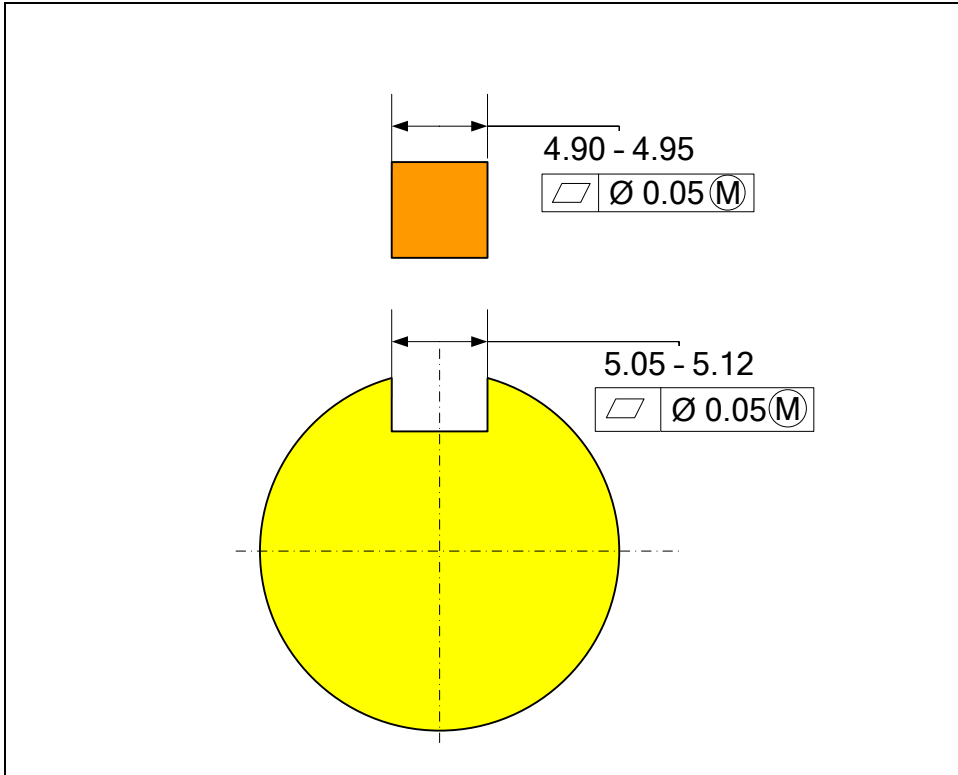


Figure 5-28. Fit of a key and a keyway

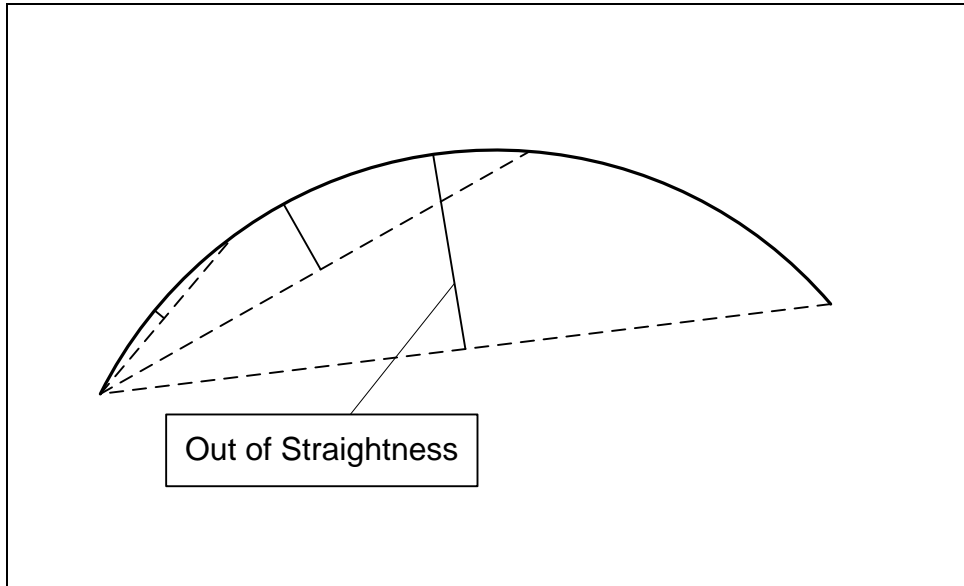
The fit tolerances are specified as shown in the figure. Determine:

- a) The MMC and LMC sizes of the key and keyway
  - b) The size of the key and keyway fit boundaries
  - c) The amount of center plane bending allowed when the key is made at 4.95 mm
  - d) The amount of center plane bending allowed when the keyway is made at 5.05 mm
  - e) The equivalent size limits for key and keyway when the flatness tolerances are converted to zero value at MMC
  - f) When the key and the keyway fit, what is the minimum and maximum possible play in the fit
4. An off-the-shelf ground steel shafting has a nominal diameter of 8 mm and a size tolerance of  $(-0.005,+0)$ . The manufacturer indicates that the shaft straightness is held to within 0.0003 mm/mm.

Determine:

- a. The MMC and LMC sizes of the shaft
- b. The fit boundary associated with a 10 mm length of the shaft
- c. The maximum out of straightness that may result for a 100 mm length of the shaft

Figure 5-29 shows how out-of-straightness increases with the length of the shaft for a constant per unit length straightness.



**Figure 5-29. The out-of-straightness accumulates rapidly with feature length**

Hint for part (c): An approximate formula for obtaining the maximum out-of-straightness of any length of a shaft given per unit length bending of a shaft is

$$t_L = \left( \frac{L^2}{l^2} \right) t_l$$

In this formula,  $t_l$  is the straightness over a given length of a shaft  $l$ . The resulting straightness over a length  $L$  of the shaft is  $t_L$ . In this problem  $l=1$  mm,  $t_l = 0.0003$  mm, and  $L=100$  mm for the last question.

# Chapter 6

## Tolerance Design for Unconstrained Fits Between Two Parts

### Part-II

#### 6.1. Overview

The previous chapter introduced the general concepts regarding unconstrained fits. Arbitrary size limits and large straightness or flatness tolerance values were used to better convey the concepts. In practice, the designer should exercise great care in the selection of size tolerance values in unconstrained fits because the fit plays (or interferences) are critical for proper function of precision joints. For precision bearing fits and other unconstrained fits size tolerances are very small. Slight deviations from what works can easily lead to non-functioning fits or excessive and unnecessary manufacturing costs. This chapter presents the necessary guidelines that can help design engineers to quickly select the correct size limits for precision fit applications in machine design and assure proper function while using the most economical tolerances.

Figure 6-1 shows an extension shaft that fits over a drive shaft and extends it. A gear is mounted at the free end of the extension shaft and is used to drive a gearbox, which is not shown. The extension shaft is shown in transparent display state to show the drive shaft.

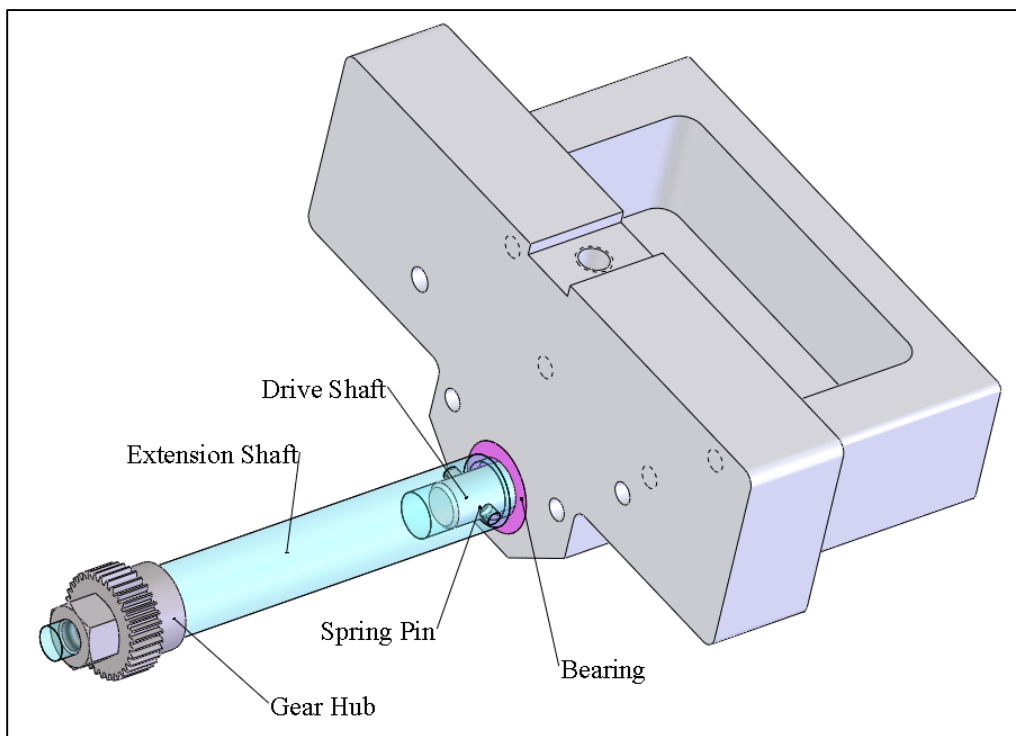
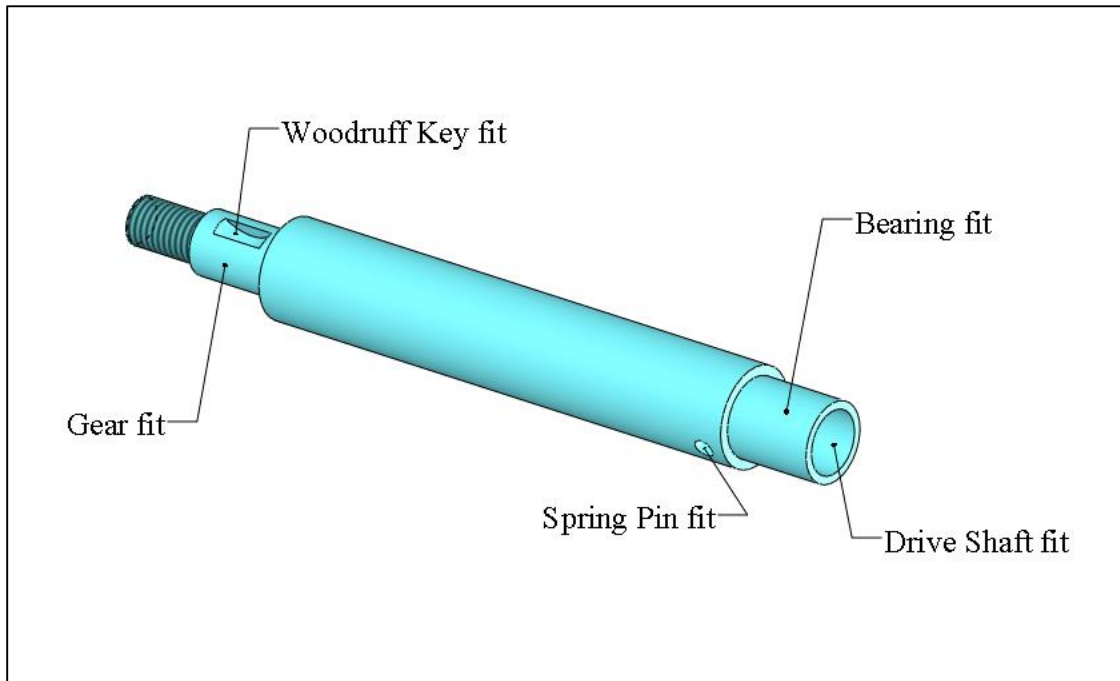


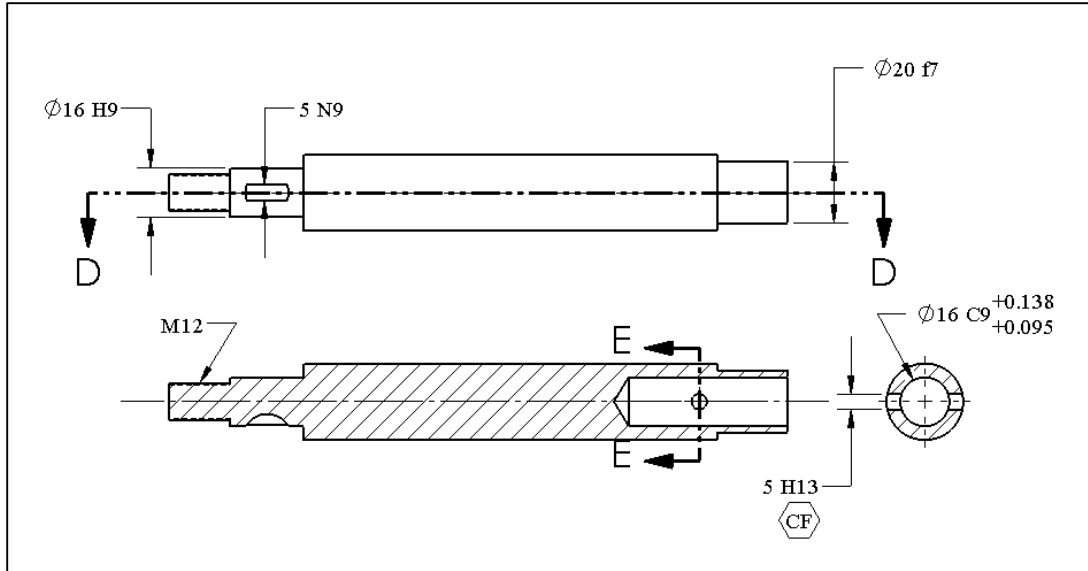
Figure 6-1. Extension shaft assembly

Figure 6-2 shows the features and precision fits associated with the extension shaft. The designer must carefully specify the size limits of the features shown in the figure.



**Figure 6-2. Critical fits associated with the extension shaft**

Determining the correct size limits that work properly for the gear fit, the bearing fit, the Woodruff key fit, the spring pin fit, and the drive shaft fit is not easy without helpful design guidelines. Relying on guesswork for the size limits of such fits almost always leads to inferior selections. Using the information in this chapter allows a designer to quickly specify the correct and most economical size limits for a variety of unconstrained fits. The end result would be size specifications in either a coded format or as numerical limits (or both) as shown in Figure 6-3 for the extension shaft.



**Figure 6-3. Precision size limits specified for an extension shaft**

The tolerancing of this extension shaft will be discussed again at the end of this chapter to illustrate the solution details.

The standard of limits and fits, ANSI B4.2, defines a list of size limits in coded format. The coded format includes both letters and numbers. For example, the code  $25f7$  is equivalent to size limits of 24.980 – 24.959 mm. The advantage of having coded size limits is that manufacturers of standard parts, such as bearings and gears, can express the tolerances associated with their products in coded form. This eliminates the possibility of error and allows quick communication of part precisions. Manufacturers can also recommend mating part tolerances that fit their parts in coded format. Another advantage of coded limits is that it allows design engineers to quickly determine adequate size limits for a variety of common applications.

## **6.2. An overview of the limits and fits standard (ANSI B4.2)**

A general understanding of how coded size limits convert into numerical limits is helpful in selecting the best size limits for fitting components. Coded size limits are made up of three designators. The first designator is the basic or theoretical size. For example, in the code  $25f7$  for a shaft feature, the number 25 is the basic size. In a fit, the basic size should be the same for both the hole and the shaft. The second designator is a letter that indicates an offset or basic size modifier. In  $25f7$ , the letter  $f$  is an offset designator. The offset values can be looked up in the tables in the standard and in the case of  $f$  offset, the value is -0.02 mm. The offset modifies the basic size of the shaft from 25 mm to an offset size of 24.98 mm.

The offset size indicates one of the size limits. The offset size is usually the desired size if manufacturing could produce the part with exact precision. The other size limit is

determined by adding or subtracting a size tolerance value. The third designator is an index number representing a tolerance value. In the case of  $25f7$  the tolerance index is 7 leading to a tolerance value of 0.021 mm when looked up in the International Tolerance Grade table. The two limits  $25f7$  and  $25f16$  both indicate a desired 24.98 mm size but the  $25f7$  allows little deviation from that desired size while  $25f16$  allows a lot. The main cost of creating a feature within size limits is associated with the tolerance index. Figure 6-4 shows the conversion of the limit codes to actual size limits for the  $25f7$  specification. In this case, the offset size is the largest limit of size and the tolerance value subtracts from the offset size to define the other limit.

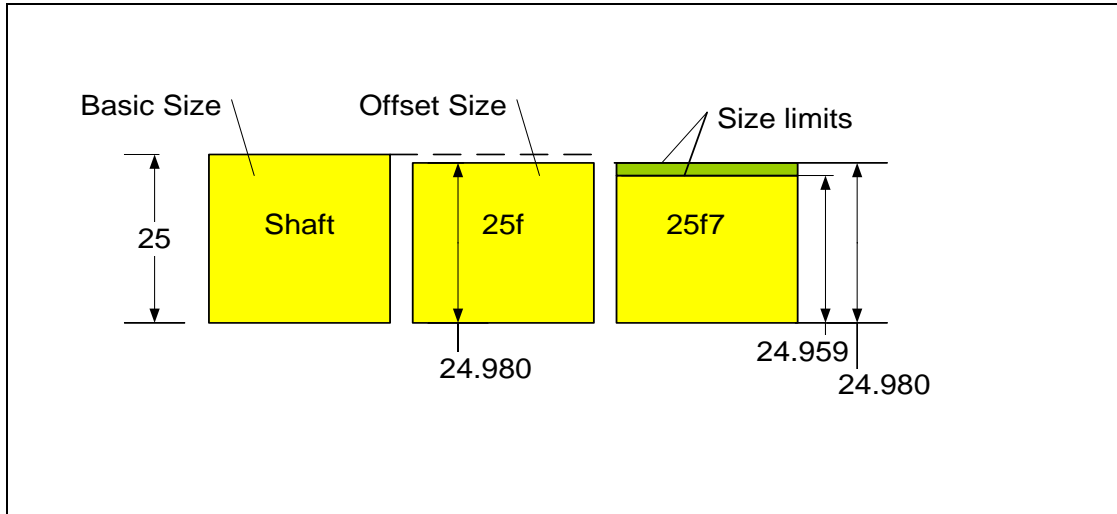


Figure 6-4. Conversion of size limit codes to actual size limits

Most CAD systems allow a design engineer to select size limits based on limits and fits coded format. The selections are then automatically converted to size limits and placed on the model drawings if desired. The narrow size limits in this example are typical of size limits necessary to achieve bearing fits or other precision fits in machine design. In the case of  $25f7$ , the total size tolerance is 0.021 mm. For comparison, the thickness of regular household aluminum foil is 0.024 mm.

Fit is a relationship between two mating features and is characterized by extreme limits of looseness or tightness. The loosest fit occurs when the largest holes (within its limits of size) fit the smallest shafts, i.e. both features are at their least material state. The tightest fit occurs when the smallest holes fit the largest shafts, i.e. both features are at their maximum material state. The following sections present the information necessary to guide the design process in selecting proper size limits for common precision fits. Before reading the rest of this chapter you can try the LAF Excel program that converts any coded size limits to numerical limits. The program can be downloaded from the book web site. The program also finds the extreme fit values for any combination of holes and shafts. After running the LAF program and invoking the associated macro, you should see the following dialog window.

Preferred Metric Limits and Fits - ANSI B4.2

Hole Feature			Shaft Feature		
<input checked="" type="radio"/> First Choice	25		<input checked="" type="radio"/> First Choice	25	
<input type="radio"/> Second Choice	18		<input type="radio"/> Second Choice	18	
<input type="radio"/> Other	23		<input type="radio"/> Other	23	

Hole Limits Information			Shaft Limits Information		
<input type="checkbox"/> Select From Hole-Basis Preferred Fits	[Dropdown]		<input type="checkbox"/> Select From Shaft-Basis Preferred Fits	[Dropdown]	
Fundamental Deviation	H	IT Grade 8	Fundamental Deviation	f	IT Grade 7

Calculated Hole Limits			Calculated Shaft Limits		
Size Tolerance	Lower Limit	Upper Limit	Size Tolerance	Lower Limit	Upper Limit
0.033	25	25.033	0.021	24.959	24.98

Calculated Fit	
Minimum Clearance	Minimum Interference
0.02	
Maximum Clearance	Maximum Interference
0.074	

The yellow boxes on the left side are to input coded size information about holes. In this case, the user has selected 25 mm basic size, an offset code of H, and a tolerance grade of 8. The corresponding numerical hole limits are calculated to be between 25.000 and 25.033 mm leading to a size tolerance of 0.033 mm. The green boxes on the right side are to input information about shafts. In this case the basic size is also 25 mm, the offset code is *f* and the tolerance grade is 7. The corresponding size limits for the shaft are calculated to be between 24.959 and 24.980 mm with a size tolerance of 0.021 mm. The blue box on the bottom of the screen indicates the extreme fit values, which in this case, is a clearance of 0.020 mm for the tightest fit and a clearance of 0.074 mm for the loosest fit.

### 6.3. Preferred sizes

When selecting basic sizes for unconstrained fits, the designer should give preference to sizes that are likely to have available off-the-shelf tooling or components. For example, there is a good chance of finding 10 mm drills, 10 mm ground shafting, or 10 mm bore size bearings. It is unlikely to find any tooling or components at odd sizes. For economic reasons, the best choices for precision fit applications are the sizes that the ANSI B4.2 standard has defined as preferred basic sizes. When having a choice, selection from these

preferred sizes often leads to lower production costs. Off-the-shelf parts and tooling are often made at other standard sizes as well. For example, drills and reamers are made at finer size steps than the standard preferred sizes. When selecting basic sizes for holes intended to be drilled or reamed, selection from the list of widely available tool sizes is as good as selection from the list of standard preferred sizes. The list of the preferred first choice and second choice sizes can be seen in the choices for basic size specification in the LAF program.

#### 6.4. Offsets letters (fundamental deviations indicator letters)

Offset values designated by letters modify a feature's basic size for the application. Offsets directly relate to the function of the fit as they dictate the desired tightness or looseness of the fit. We can think of offset sizes as the exact sizes needed for application. By changing the offset letters the designer influences the characteristics of the fit. Offset designators use lowercase letters for shafts and uppercase letters for holes. Offset designator letters from *a* to *h* are negative and reduce the basic size of a shaft and are usually intended for clearance fits. The offset value for *h* is zero. For example, the offset size of a  $25h9$  shaft is 25 mm. Figure 6-5 shows the relative change in offset sizes for *a* to *h* offsets for a 25-mm basic size shaft. The offsets in the figure are exaggerated for illustration.

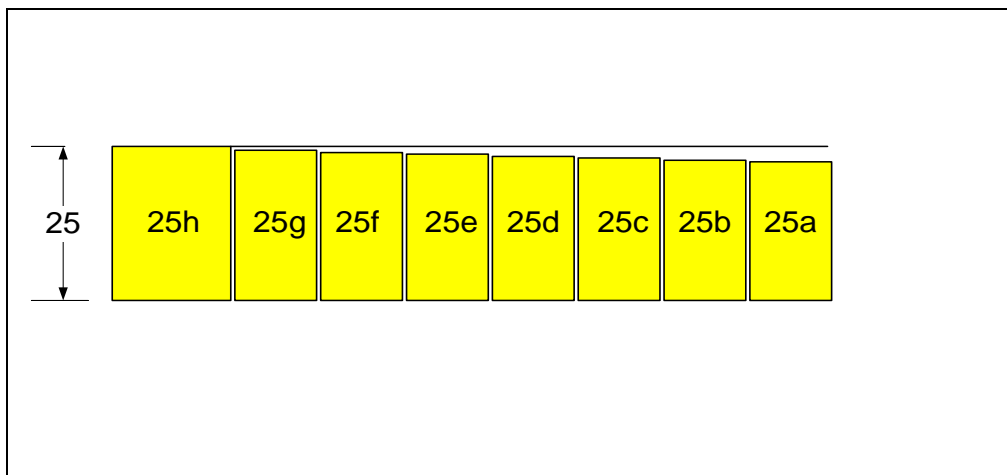
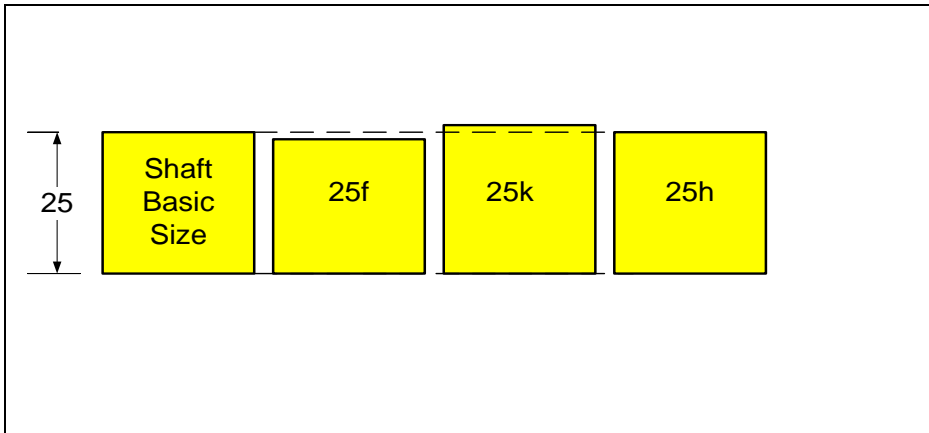


Figure 6-5. Relative offset sizes for various shaft codes

Offsets letters after *h* increase the basic size of the shaft and are usually intended for interference fits. Figure 6-6 shows the offset sizes for a shaft with a basic size of 25 mm and offset designators of *f*, *k*, and *h*.



**Figure 6-6.** The offset size of *25f* is smaller than the basic size while the offset size of *25k* is larger and the offset size of *25h* is the same as the basic size

Similarly for holes, offset designator letters before letter *H* increase the basic size of a hole and are intended for clearance fits. Offsets after letter *H* reduce the basic size of the hole and are intended for interference fits. The offset for letter *H* is zero. When designers are free to select both fitting features in a joint, they often select an H offset for the hole and then select the shaft offset to create the fit suited to the application. For that reason, other offsets associated with holes are not further elaborated here. When a shaft is to fit to an H-class hole, the mating shaft offsets before letter *h* are used for clearance fits and offsets after letter *h* are usually result in interference fits. There is also a class of fits between clearance and interference fits that would allow a fit to be slightly clearance or interference. These fits are called transition fits and are primarily used in rolling element bearing fit applications.

Offset values adjust with the feature size. The following table shows a sample of offset values for letters *a-g* for 10 and 25 mm features. The negative values mean that the offset value makes the offset size smaller than the basic size for shafts.

Offset	<i>a</i>	<i>b</i>	<i>c</i>	<i>d</i>	<i>e</i>	<i>f</i>	<i>g</i>
10 mm	-0.290	-0.150	-0.095	-0.05	-0.032	-0.016	-0.006
25 mm	-0.300	-0.160	-0.110	-0.065	-0.040	-0.020	-0.007

The larger the feature size, the larger the offset values for the same offset code. As mentioned before, the offset size defines one limit of size. The other limit of size is determined by adding or subtracting a size tolerance. For example, the offset size of a *25d9* shaft is 24.935 and this limit defines the upper limit of size. The lower limit is calculated by subtracting the tolerance value of 0.052 from the upper limit.

## 6.5. International tolerance grades

Standard tolerance values, known as the International tolerance grades (IT grades) are developed by the International Organization for Standardization (ISO). IT grades start with the narrowest range of IT01 and extend to IT16 and higher. IT grade values also adjust with the basic feature size. The larger the feature size, the larger the tolerance values for the same tolerance grade. For a 25 mm feature, the IT01 tolerance value is only 0.0006 mm while the IT16 tolerance is 1.3 mm. Note that the tolerance values represent the difference between the largest and smallest diameters or widths of a feature. The following table shows the most commonly used IT grades in machine design ranging from IT5 through IT11 for two example sizes of 10 mm and 25 mm.

IT Grade	IT5	IT6	IT7	IT8	IT9	IT10	IT11
10 mm	0.006	0.009	0.015	0.022	0.036	0.058	0.090
25 mm	0.009	0.013	0.021	0.033	0.052	0.084	0.130

Tolerance grades IT01 to IT4 are only used for extreme needs of fit or alignment and are usually reserved for measurement and gaging equipment. Common applications in the design of machinery utilize tolerance grades IT5 through IT11 with IT6-IT9 being the most common range for precision fits. Fits that involve plain bearings and rotating shafts usually need IT6, IT7, or IT8 tolerance grades. Rolling element bearings mostly use grade IT6 or IT7 tolerances while the highest precision rolling-element bearings may require grade IT5. Smaller tolerance grades for fitting features lead to less variation of fit clearances or interferences but they also lead to a more expensive production. The table of IT grade values for IT01 to IT16 classes can be found in the LAF program by clicking on the IT grades worksheet. The following shows a portion of the table.

From	To (Including)	IT01	IT0	IT1	IT2	IT3	IT4	IT5	IT6	IT7
0	3	0.0003	0.0005	0.0008	0.0012	0.002	0.003	0.004	0.006	0.01
3	6	0.0004	0.0006	0.001	0.0015	0.0025	0.004	0.005	0.008	0.012
6	10	0.0004	0.0006	0.001	0.0015	0.0025	0.004	0.006	0.009	0.015
10	18	0.0005	0.0008	0.0012	0.002	0.003	0.005	0.008	0.011	0.018
18	30	0.0006	0.001	0.0015	0.0025	0.004	0.006	0.009	0.013	0.021
30	50	0.0006	0.001	0.0015	0.0025	0.004	0.007	0.011	0.016	0.025
50	80	0.0008	0.0012	0.002	0.003	0.005	0.008	0.013	0.019	0.03
80	120	0.001	0.0015	0.0025	0.004	0.006	0.01	0.015	0.022	0.035
120	180	0.0012	0.002	0.0035	0.005	0.008	0.012	0.018	0.025	0.04

The two left columns indicate the feature size range in mm. The top row shows the IT grades. For a 25 mm feature size with IT grade of 7, the size tolerance is 0.021 mm.

## 6.6. Preferred fits

The ANSI B2.4 standard provides 10 classes of fits as design templates to help designers select size limits for various applications. These fits are called preferred fits and are composed of 5 classes of clearance fits, 2 classes of transition fits, and 3 classes of interference fits. In the transition fits, the specifications allow for the fit to be slightly clearance or slightly interference. One of these 10 preferred fits usually provides a good

starting point for the selection of the appropriate size limits of fitting features for common machine design applications. The list of preferred fits in B4.2 is intentionally kept short to make it easier to initially map them to applications. This means for some applications, the designer may have to make adjustments when analysis or experiments warrant modifications. When modifying size limits, the designer can modify the offsets to influence the fit tightness or looseness. Reducing tolerance values or IT grades prevent excessive deviations from the desired fit play or interference. Preferred fits have three common characteristics. These characteristics provide a general guideline to follow when designing size limits for any precision fit.

- a) *The hole feature uses H-class limits.* This means the hole size is allowed to be at or slightly larger than the nominal size. The IT grade determines how large the hole is allowed to be.
- b) *The IT grades associated with the hole and shaft are either the same number or off by only one IT grade.* This is a good practice as dividing the required tolerances evenly between fitting features usually leads to the lowest production cost. Shafts can often be made slightly more precisely than holes, using the same amount of effort or cost. Favoring a slightly more precision shaft is usually better than slightly more precision hole.
- c) *The IT grades are in the range between IT6 and IT11.* This is the most common range of precisions necessary for machine fits. Occasionally an IT5, or rarely an IT4, may be needed for high precision rolling element bearings.

Once a suitable range of fit plays or interferences is selected based on the preferred fit recommendations, the designer should consider altering them slightly for better function and for more cost-effective production. Alteration of fit plays and interferences may be necessary when economics, experiments, simulation, or theoretical studies justify their change. The following table shows a general description of the 10 classes of preferred fits and their typical application. The list is ordered starting with the fit that allows the most clearance to the heaviest interference fit that creates the tightest connection. You can use the LAF program to check the fit clearances or interferences for specific sizes.

Fit	Code	Typical Application
<i>Loose Running Fit</i>	<i>H11/c11</i>	Shaft collar fits
<i>Free Running Fit</i>	<i>H9/d9</i>	Motor shaft fits to plain bearings in hydrodynamic lubrication situations
<i>Close Running Fit</i>	<i>H8/f7</i>	Precision motor shaft fits to plain bearings
<i>Sliding Fit</i>	<i>H7/g6</i>	Precision sliding motion between a plain bearing and a guide rod
<i>Locational Clearance Fit</i>	<i>H7/h6</i>	Gear fits
<i>Locational Transition Fit-I</i>	<i>H7/k6</i>	Rolling element bearing fits
<i>Locational Transition Fit-II</i>	<i>H7/n6</i>	Rolling element bearing fits
<i>Locational interference Fit</i>	<i>H7/p6</i>	Bearing fits
<i>Medium Drive Fit</i>	<i>H7/s6</i>	Load carrying fits
<i>Force Fit</i>	<i>H7/u6</i>	Permanent load carrying fits

The preferred fits shown in this table are called hole-basis preferred fits because they all use  $H$ -limits on the holes. Occasionally, it is more economical to select an  $h$ -class shaft and determine the hole limits to achieve a desired fit. For every hole-basis preferred fit there is a corresponding shaft-basis preferred fit with identical fit performance. For example, the performance of close running fit,  $H8/f7$  in hole-basis fits can be achieved with an  $h7/F8$  fit in shaft-basis fits. The rules for selection of fitting feature sizes is the same as those stated for  $H$ -class fits except that the shaft feature will have an  $h$ -class size limits.

### Five classes of clearance fits

A clearance fit is a fit that leads to a play of zero or more. For the five classes of preferred clearance fits the combination of the letter codes (offset codes) always determines the minimum play amount for any particular basic size. For example, an  $H/f$  fit has a minimum play of 0.02 mm for a 25 mm size feature regardless of the tolerance grades used. That means both  $25H8/f7$  and  $25H12/f11$  have a minimum play of 0.02 mm. The tolerance grades determine the maximum possible play. The maximum possible play for  $25H8/f7$  is 0.074 mm while the maximum possible play for  $25H12/f11$  is 0.38 mm. Usually, in the design of clearance fits the designer likes to have a minimum amount of play and selecting the offset codes alone determines that desired minimum play. The designer then selects the combination of tolerance grades that would not lead to objectionable looseness in the fit. For example, a  $25H8/f8$  has a maximum possible play of 0.086 mm compared to 0.074 mm for  $25H8/f7$ .

#### *H11/c11 Loose Running Fit*

The word “running” refers to a continuous motion of a motor shaft in a bearing but despite being named a running fit, the fit in  $H11/c11$  can become too loose for most bearing applications in machines. The fit can be used where excessive play in the joint is not objectionable and some looseness in the fit is desirable for ease of assembly. Examples include shaft collars, belt pulleys, or other non-critical fits. For a 25 mm basic size, the fit play can range from 0.11 mm to 0.37 mm. The designation of “loose” is a little misleading because the fit does not allow a lot of wiggle room (0.11 mm is about the thickness of one sheet of copy paper). The IT11 class tolerances are wide and can be held by machining, shearing, cold forming, or precision casting processes.

#### *H9/d9 Free Running Fit*

This fit is adequate for journal bearings running at high loads and speeds. The relatively large clearance in the fit allows the formation of full-film lubrication that carries the load. The fit play however may be objectionable leading to excessive radial runout of the shaft, especially when the load direction changes. This fit should not be used when accuracy of motion is critical, such as in manufacturing equipment or motor shafts driving gears. An application example is the fit of a connecting rod to the crank shaft in an automobile engine as shown in Figure 6-7. Also, static shaft components such as collars can use this fit.



**Figure 6-7. Free running fit is adequate for the connecting rod to crank shaft fit**

For a 25 mm basic size, the fit play can range from 0.065 mm to 0.169 mm. Theoretical calculations for minimum film thickness must be made to determine how the fit should be altered to better match the application. The IT9 class tolerances can be held by medium-precision processes such as average turning and boring processes.

#### *H8/f7 Close Running Fit*

This is the proper fit for most plain bearings that support gearbox shafts where the loads and speeds are moderate and the accuracy of motion is important. The small play allows thin lubrication films to carry moderate radial loads at moderate speeds. Most electric motors that use plain bearings use this kind of fit. The fit of the wrist pin to the connecting rod, shown in Figure 6-8, is another example of an application of close running fit.



**Figure 6-8. Close running fit is adequate for the wrist pin fit to the connecting rod**

For a 25 mm basic size, the fit play can range from 0.020 mm to 0.074 mm. The IT8 and IT7 class tolerances can be held by precision processes such as reaming, finish turning, or finish boring on short lengths of fit.

#### *H7/g6 Sliding Fit*

Sliding fit clearances are too small to be adequate for lubricating continuous or high speed motion plain bearings. Small clearance hinders the flow of lubrication into the joint causing problems. In such fits, there is always a risk of slight temperature variations causing the joint to seize. This fit is adequate for slow-speed precision rotating or sliding motions when the joint is properly greased, or uses self-lubricating bearings. An example is the fit of a printer head bearing and its guiding rod as shown in Figure 6-9.



**Figure 6-9. Sliding fit is adequate for guide bar fit to the sliding carriage of a printer**

Note that there is a short bearing press-fitted at each end of the slider as shown in Figure 6-10. The length of fit between the guide rod and the plain bearing is equal to the width of a single bearing. It may appear that once the guide rod is fit through the first bearing its fit to the next bearing would not be an unconstrained fit. However, the small clearance in the bearing fit provides enough free play for the end of the rod to center itself with respect to the second bearing when there is sufficient distance between the bearings.



**Figure 6-10. Sliding fits often includes two narrow plain bearings at a distance**

Sliding fit can also be used where accuracy of locating is critical on joints that need to be frequently and freely positioned. For a 25 mm basic size, the fit play can range from 0.007 mm to 0.041 mm. The IT6 class tolerances can be held with high precision processes such as precision reaming, grinding, or diamond turning or boring.

#### *H7/h6 Locational Clearance Fit*

As the name implies, locational fits are used to locate parts with respect to each other with high precision allowing very little play. The H7/h6 is a snug fit but still a clearance fit that allows the fitting features to be freely assembled and disassembled such as with removable dowel pins or gears. The use of *H/h* offset letter combination means the holes are at or slightly over the basic size and the shafts are at or slightly smaller than the basic size. Typical fit examples include precision shaft components such as gears, hubs, or couplers that are removable but require precise centering and snug fit. Figure 6-11 is an example of a gear fit designed to have a snug fit but easily slide out.



**Figure 6-11. Locational clearance fits are adequate for gear fits which often require free assembly with precision centering and little play**

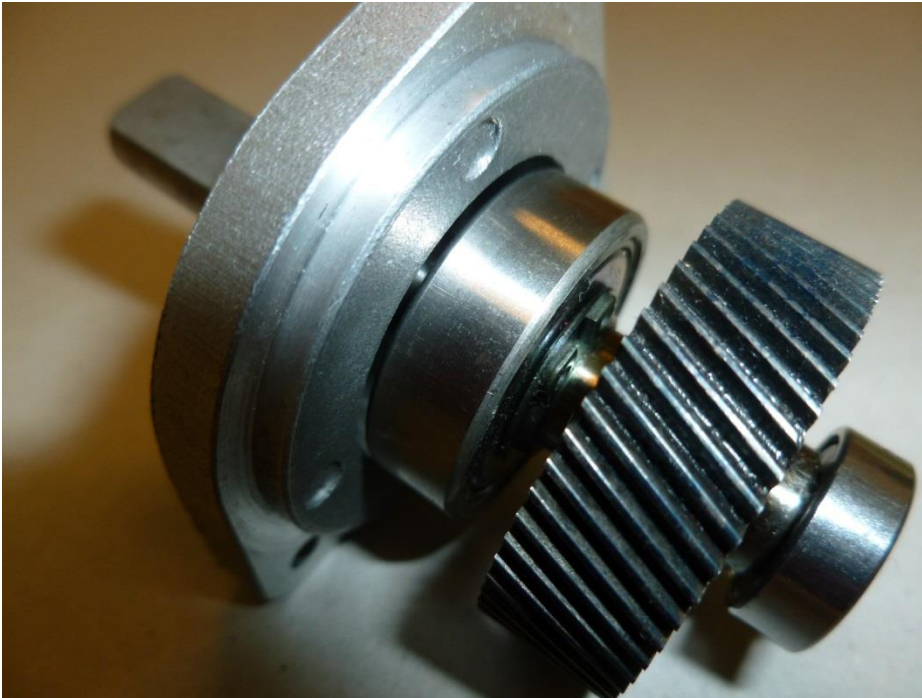
For a 25 mm basic size, the fit play for H7/h6 can range from 0 mm to 0.034 mm. With a maximum possible play of 0.034 mm, this fit provides moderate tightness and locating capability. Fits that do not require as much snugness can use H8/h8 or even H9/h8 but only H7/h6 is called the locational clearance fit.

## Two classes of transition fits

A transition fit is a fit that allows either a clearance fit or an interference fit. The loosest possible fit is a clearance fit and the tightest fit is an interference fit. Usually in the design of transition fits the designer is concerned with both the maximum amount of possible play and the maximum amount of possible interference. To make a fit tighter using the same tolerance indices, the designer should select a code with higher positive offset value. Common codes for practical transition fits are  $k$ ,  $m$ ,  $n$ , and  $p$  with  $p$  leading to the tightest transition fit.

### *H7/k6 Locational Transition Fit-I*

There are two classes of preferred transition fits with  $H/k$  being the looser one. Both classes of transition fits are primarily intended for rolling-element bearings. The  $H/k$  transition fit is usually used between the OD of a ball or roller bearing and the bearing housing. A slight pressure or temperature difference may be required for fit. This type of fit can also be used in other applications requiring high precision locating between parts. Figure 6-12 is an example of a bearing OD fit to a bearing hole where the  $H/k$  transition fit is adequate. In this case, the fit is slightly clearance and the bearing can slide in and out without force.



**Figure 6-12. Lighter transition fits are used for ball bearing fits to bearing housing**

For a 25 mm basic size, the fit play can range from 0.019 mm clearance to 0.015 mm interference. This fit is also adequate for dowel pins that fit rigidly and locate the pieces of a molding die or a work-holding fixture. A designer who likes to increase the IT

grades tolerance slightly to H7/k7 would see the maximum possible interference increasing to 0.023 mm while the maximum clearance remains the same.

#### *H7/n6 Locational Transition Fit-II*

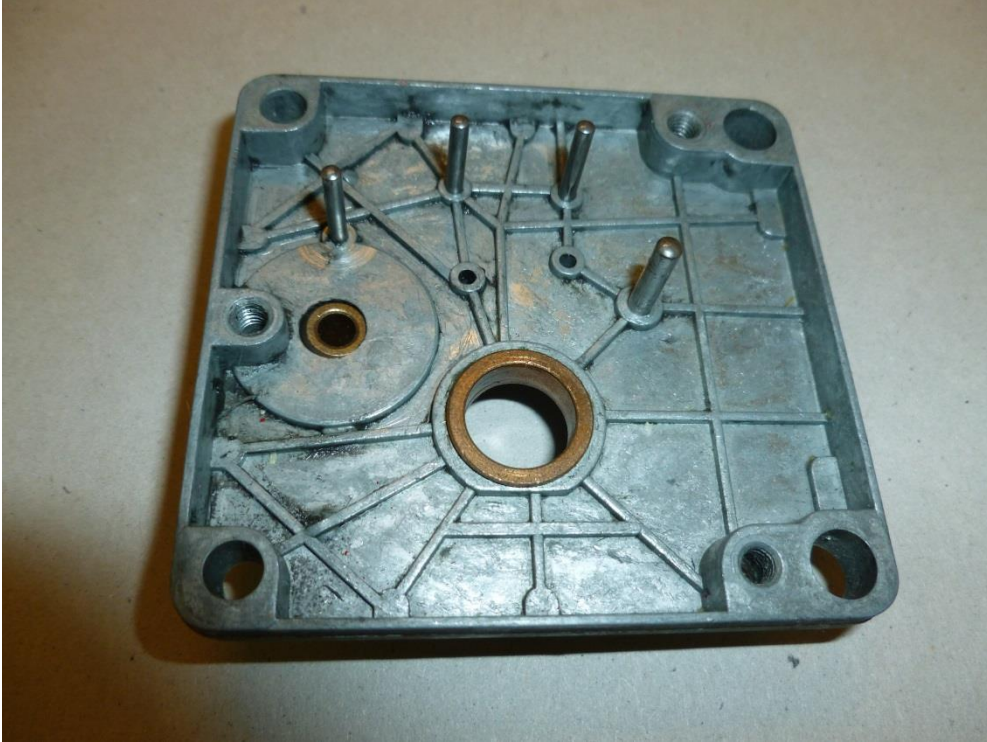
*H/n* is a slightly tighter transition fit than the *H/k* fit. The fit is frequently used with the rolling-element bearing fits between the shaft and the bearing bore where a tighter fit is required to prevent slippage. In Figure 6-12, the fit between the bearings and the shaft is similar to *H7/n6* locational transition fit. A small pressure or temperature difference is usually required for the locational transition fit. For a 25 mm basic size, the fit play can range from 0.006 mm clearance to 0.028 mm interference.

### **Three classes of interference fits**

In the design of interference fits the designer likes to assure a minimum amount of interference to achieve adequate functional rigidity for load transmission capacity. The shaft offset code usually ranges between *p* and *u* with higher order letters leading to tighter fits.

#### *H7/p6 Locational Interference Fit*

This light interference fit is primarily used with high-speed rolling-element bearing fits between the bearing bore and the shaft when the shaft is subjected to sudden speed changes. It is also adequate for the fit of plain bearings into their housing. The fit provides accurate and rigid connection between the mating features such as press-fit posts. The interference is light and the joint is not expected to carry appreciable forces or torques. Figure 6-13 shows a gearbox housing with a plain flanged bearing fit to the housing and a number of gear fit posts. Both the flanged bearing fit and the fit of the posts into the housing are similar to locational interference fits.



**Figure 6-13. A light interference fit is adequate for plain bearing fit to its housing**

For a 25 mm basic size, the fit interference can range from 0.001 mm to 0.035 mm. The temperature difference required to achieve a shrink fit for the maximum interference of 0.035 mm is about 130 degrees centigrade for 1-inch diameter fit of steel parts.

#### *H7/s6 Medium Drive Fit*

*H7/s6* is an interference fit intended to carry moderate loads and torques. In low cost machines heavy interference fits are often accomplished by creating serrated surface forms. Figure 6-14 shows an interference gear fit in which the shaft surface is serrated. With this design a heavy fit can be accomplished with less size precision and lower forces. The torque carrying performance of this fit, however, is less predictable than a medium drive fit.



**Figure 6-14. Extreme precisions and high forces required for a medium drive fit can be avoided by a serrated shaft surface**

For a 25 mm basic size, the fit interference can range from 0.014 mm to 0.048 mm. The temperature difference required to achieve a shrink fit for the maximum interference of 0.048 mm is about 178 degrees centigrade for 1-inch diameter steel parts. This is usually the heaviest fit for grey cast iron parts.

#### *H7/u6 Force Fit*

Force fits are permanent heavy interference fits intended for steel parts with sufficient tensile strength and ductility to withstand the required forces and deformations. For a 25 mm basic size, the fit interference can range from 0.027 mm to 0.061 mm. Heavy press forces or large temperature differences are required to achieve these fits. The temperature difference required to achieve a shrink fit for the maximum interference of 0.061 mm is about 226 degrees centigrade for 1-inch diameter steel parts.

Preferred fits provide a good starting point for the selection of best size limits for a variety of applications. In some cases, analysis, experimentation, or economic reasons necessitate a deviation from these preferred fits. Adjustments to offsets change the characteristic of the fit by making it tighter or looser while adjustment of tolerance grades controls the extent of deviations from the intended tightness or looseness and influence the cost and quality of the fit.

## 6.7. Dependency of offsets and tolerance grades on basic size

One of the advantages of coded tolerance zones is that they adjust with the basic size. International tolerance values for the same IT grade increase with feature size. Offset values also increase with the basic size for any offset designator, except for  $H$  and  $h$  designators which always have zero values. This organization of tolerance and offset values is helpful to the design engineers selecting size limits for proper function. For example, an  $f7$  size limit designator for a shaft along with an  $H8$  designator for the mating hole create fits that are generally adequate for journal bearings regardless of the basic size. As the feature size increases, the joint play also increases to provide adequate lubrication film thickness for the bearings to operate properly. The combination of  $H8/f7$ , which is the close running fit, provides a functionally similar performance for all basic sizes.

The size adjusted organization of coded size limits also helps the manufacturing. A shop personnel seeing an  $f7$  or  $H8$  size limits can quickly assess the required degree of precision necessary to create them. Manufacturers of components such as bearings can recommend fit requirements with a single code for all sizes of a class of bearings. For example, a bearing can be recommended to have an  $m6$  fit for all the sizes in a class. The use of IT grades was also suggested in Chapter-4 for default profile tolerances to create adequate tolerance values for both large and small features.

## 6.8. Tolerance design examples in precision fit applications

With a general understanding of preferred fits a designer can quickly specify the size limits of features in precision fits. The specified limits would often provide adequate function using the widest tolerance zones. While coded size limits can be used to indicate any dimension limits, their use should be limited to features-of-size in direct fit applications. Coded limits should only be used with preferred or industry-standard basic sizes for which off-the-shelf tooling or components are available. Finally, despite their advantages, coded limits present a discrete and limited set of size limits to a design engineer. When exact size limits needed for the application do not match any coded limits, the best option is to use the exact numerical size limits. A number of examples will illustrate the fit design procedures.

**Example-1:** A ball bearing with a nominal bore diameter of 25 mm is to fit a shaft. The manufacturer has recommended an  $m5$  tolerance zone for the shaft. Figure 6-15 shows the fit situation.

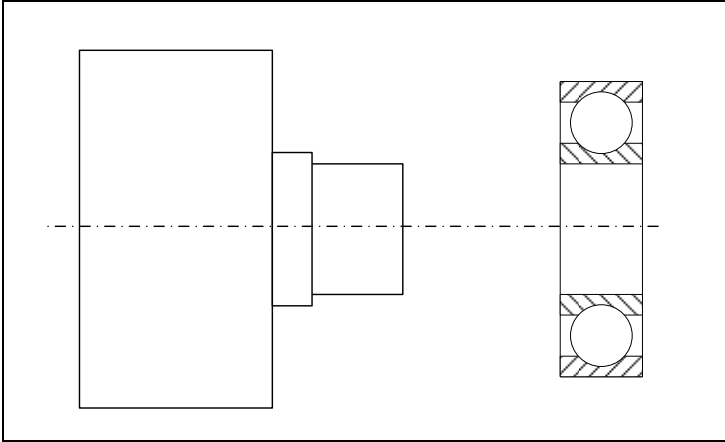


Figure 6-15. Shaft limits for a ball bearing fit based on manufacturer's recommendation

The ball bearing bore limits are given as 24.99-25.00 mm. For this situation,

- Place the required tolerance specification on the shaft drawing.
- Find the numerical size limits of the shaft using the LAF program.
- Determine the closest coded limits to the bearing bore size limits.
- Calculate the fit play range in mm.

### Solution

**Part a)** Since the manufacturer has recommended the limits of the mating feature, the size limits are directly specified in coded format. Figure 6-16 shows the result.

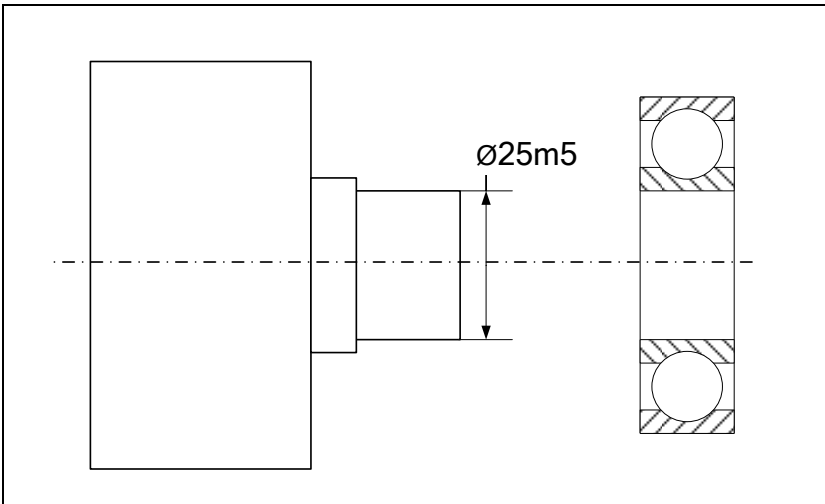


Figure 6-16. A ball bearing fit

**Part b)** Using the LAF Program, the size limits of the shaft corresponding to 25m5 are 25.008 – 25.017 mm.

**Part c)** The bearing bore size tolerance is 0.01 mm. Using the table of IT grades, the closest size tolerance for a 25 mm feature is 0.009 mm for grade 5. After a few trials with the LAF program, the 25K5 limits (24.992 – 25.001 mm) is found to be the closest coded limits to the actual bearing bore limits.

**Part d)** The loosest fit occurs when the largest bore is matched with the smallest shaft

$$P_1 = 25 - 25.008 = -0.008 \text{ mm}$$

The negative sign means this is an interference fit. The tightest fit occurs when the smallest hole is matched with the largest shaft

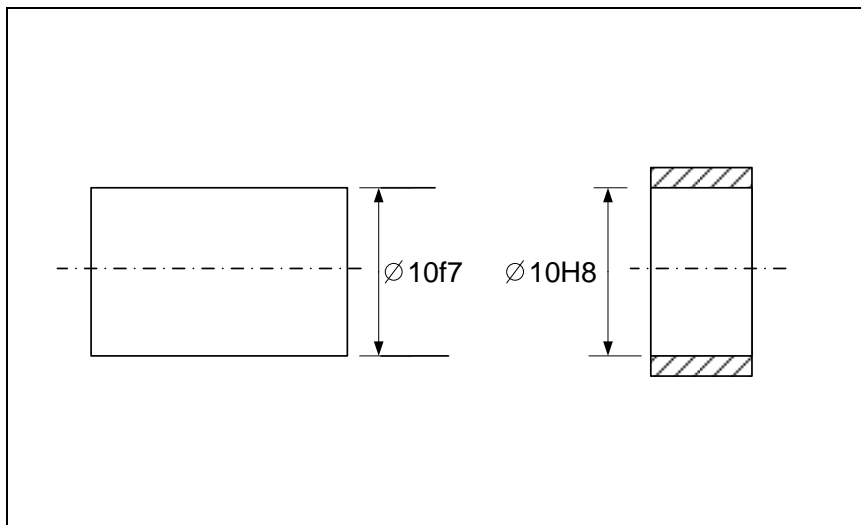
$$P_2 = 24.990 - 25.017 = -0.027 \text{ mm}$$

Therefore, the fit range is between 0.008 mm interference and 0.027 mm interference.

**Example-2:** A plain bearing (bushing) is selected to be used with a 10 mm shaft. 10 mm is the general identifying size also known as the *nominal size*. The bearing ID is specified by the manufacturer to have *10H8* limits.

- Specify the size limits of the 10 mm shaft to obtain a fit similar to a close running fit.
- Determine the minimum and maximum play in the fit.

**Solution:** The size limits for the close running fit for a 10-mm basic size are *10H8* for the hole and *10f7* for the shaft. Since the hole limits match the close running fit requirement exactly, the shaft limits must be *10f7*. The specifications are shown in Figure 6-17.



**Figure 6-17.** Designation of size limits for the fit between a shaft and a bearing bore

Using the LAF program, the minimum clearance is 0.05 mm and the maximum clearance is 0.013 mm.

**Example-3:** The plain bearing used in the previous problem is to fit a hole in a bearing housing. The size limits on the bearing OD are specified by the manufacturer to be *16h6*.

- Specify the size limits of the bearing hole to obtain a fit similar to a locational interference fit.
- Determine the closest IT grade to the hole size tolerance.

**Solution:** Using the LAF program, the minimum and maximum interferences allowed in locational interference fit for a 16 mm feature are

$$P_{min} = -0.029$$

$$P_{max} = 0$$

Also the numerical OD limits for the bearing (16h6) are

$$F_{max} = 16.000$$

$$F_{min} = 15.989$$

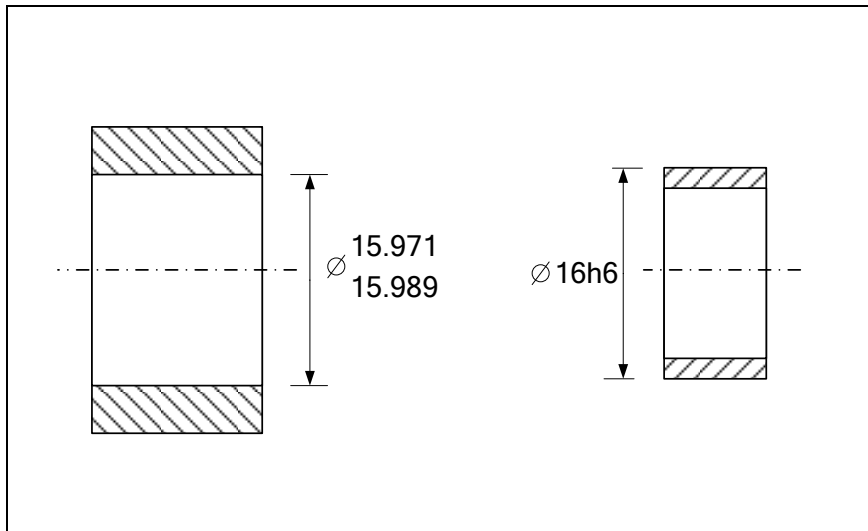
The limits for the bearing hole in the housing can be calculated as

$$P_{min} = H_{min} - F_{max} \rightarrow -0.029 = H_{min} - 16 \rightarrow H_{min} = 15.971$$

And

$$P_{max} = H_{max} - F_{min} \rightarrow 0 = H_{max} - 15.989 \rightarrow H_{max} = 15.989$$

The specifications are shown in Figure 6-18.



**Figure 6-18.** Designation of size limits for a fit between the bearing OD and the housing recess

The hole size tolerance is 0.018 mm which is exactly an IT7 tolerance grade for a 16 mm feature size.

**Example-4:** An off-the-shelf sintered bronze bearing with an ID of 10 (0, +0.02) mm is to be used to support a 10 mm shaft.

- Specify the size limits for the mating shaft to obtain a performance similar to a close running fit.
- Determine the closest IT grades for both the shaft and the ID of the bearing.

**Solution:** For a 10-mm basic size, the LAF program indicates a fit play range from +0.013 mm to +0.050 mm for the close running fit. The minimum play is

$$P_{min} = H_{min} - F_{max} \rightarrow 0.013 = 10 - F_{max} \rightarrow F_{max} = 9.987 \text{ mm}$$

The maximum play is

$$P_{max} = H_{max} - F_{min} \rightarrow 0.050 = 10.02 - F_{min} \rightarrow F_{min} = 9.970 \text{ mm}$$

The shaft size limits become 10 (-0.013, -0.030).

The tolerance value of 0.017 is slightly more than IT7 = 0.015 mm for a 10 mm size shaft. The 0.02 mm size tolerance of the bearing hole ID is slightly less than IT8 = 0.022 mm.

**Example-5:** An off-the-shelf spur gear has bore size limits of 16H7. What shaft size limits would create a fit similar to a free running fit with this gear? What is the closest IT grade to the shaft size tolerance? Create a table to show the results when the gear bore size limits are 16H8, 16H9, 16H10, and 16H11.

**Solution:** Using the LAF program, the clearance range for a performance similar to free running fit (16H9/d9) is between 0.05 mm and 0.136 mm. Also for 16H7,  $H_{min}=16.000$  mm and  $H_{max}=16.018$  mm. The minimum play formula leads to

$$P_{min} = H_{min} - F_{max} \rightarrow 0.05 = 16 - F_{max} \rightarrow F_{max} = 15.950 \text{ mm}$$

The maximum play formula leads to

$$P_{max} = H_{max} - F_{min} \rightarrow 0.136 = 16.018 - F_{min} \rightarrow F_{min} = 15.882 \text{ mm}$$

The shaft size tolerance becomes 0.068 mm. This tolerance value is slightly less than IT10 = 0.070 mm. Therefore the resulting fit has an IT7 on the hole and nearly an IT10 on the shaft. Carrying out the same calculations with other gear hole limits results in the information indicated in the table below. The first row is the solution above with 16H7 hole limits.

Hole Size Coded Limits	Hole Numerical Size Limits	Shaft Numerical Size Limits	Shaft Size Coded Limits
16H7	16.000 – 16.018	15.882 – 15.950	~IT10
16H8	16.000 – 16.027	15.891 – 15.950	IT9-IT10
16H9	16.000 – 16.043	15.907 – 15.950	IT9
16H10	16.000 – 16.070	15.934 – 15.950	~IT7
16H11	16.000 – 16.110	Not possible	Not possible

Note that for the last case, no shaft limits would satisfy the clearance range requirement because the hole size tolerance is too wide to work even with a shaft with a zero size tolerance. The hole limits for 16H11 are  $H_{min}=16.000$  mm and  $H_{max}=16.11$  mm. This amount of variation already exceed the needed range of play allowed by the free running fit which is (0.136 - 0.05=0.086 mm). This problem shows the importance of matching the precision of the two fitting components such that they use comparable tolerances.

**Example-6** An 8-mm precision dowel pin with size limits of 8 (+.006, +0.015) mm is to fit in a mating hole with 8H7 limits. Compare the resulting fits to similar preferred fits.

**Solution:** The maximum play occurs when both features are at their LMC limit of size

$$P_1 = H_{max} - F_{min}$$

$$P_1 = 8.015 - 8.006 \Rightarrow P_1 = +0.009 \text{ mm}$$

The maximum interference is

$$P_2 = H_{min} - F_{max}$$

$$P_2 = 8 - 8.015 \Rightarrow P_2 = -0.015 \text{ mm}$$

Comparison of this fit with the preferred fits is shown in the following table.

Fit	Loosest fit	Tightest fit
<b>This fit</b>	<b>+0.009</b>	<b>-0.015</b>
8H7/h6 Locational Clearance Fit	+0.024	0
8H7/k6 Locational Transition Fit-I	+0.014	-0.010
8H7/n6 Locational Transition Fit-II	+0.005	-0.019
8H7/p6 Locational Interference Fit	0	-0.024

Based on the interference values for the loosest fits, this fit with a minimum interference of 0.009 mm is slightly looser than the  $H7/k6$  which has a minimum interference of 0.014 mm. It is, however, a little tighter than  $H7/n6$  with a minimum interference of 0.005 mm.

**Example-7** A  $12H7$  gear bore is to have an interference load carrying fit with a drive shaft. It is determined that the minimum adequate radial interference must be 0.004 mm and the maximum radial interference should be equal to or less than 0.018 mm. Determine the shaft limits for the interference fit. Compare the results to the preferred fits.

**Solution:** The required diametrical interferences are to be between 0.008 mm and 0.036 mm. The minimum interference formula can be used to find the smallest shaft diameter

$$P_1 = H_{max} - F_{min} = (12+0.018) - F_{min}$$

$$-0.008 = 12.018 - F_{min} \Rightarrow F_{min} = 12.026 \text{ mm}$$

The maximum interference relation is used to find the maximum shaft diameter

$$P_2 = H_{min} - F_{max}$$

$$-0.036 = 12 - F_{max} \Rightarrow F_{max} = 12.036 \text{ mm}$$

The required size limits of the shaft are 12 (+0.026,+0.036). The total size tolerance on the shaft diameter is 0.010 mm. This tolerance value is between IT5 grade (0.008 mm) and IT6 grade (0.011 mm). The following table shows comparison of this fit to preferred fits.

Fit	Loosest fit	Tightest fit
<b>This fit</b>	<b>-0.008</b>	<b>-0.036</b>
12H7/p6 Locational Interference Fit	0	-0.029
12H7/s6 Medium Drive Fit	-0.010	-0.039
12H7/u6 Force Fit	-0.015	-0.044

Based on the interference values for the loosest fits, this fit with 0.008 mm minimum interference is less tight than the  $H7/s6$ , the medium drive fit, which has a minimum interference of 0.010 mm.

**Example-8** In a hydrodynamic journal bearing application, a designer is expected to determine the size limits for both the shaft and the bearing hole. The bearing nominal size is to be 25 mm. Calculations using hydrodynamic lubrication theory show that a clearance range between 0.025 mm and 0.06 mm would be needed. Determine suitable size limits for both the shaft and the bearing hole to meet the clearance requirements.

**Solution:** Following the general guidelines for precision fit design, we decide to have H-class size limits for the hole. This election leads to the most cost-effective limits for the fabrication of the bearing hole. Therefore

$$H_{min} = 25.000$$

$$H_{max} = 25 + t_H$$

The size limits for the shaft are to be determined to meet the fit requirements. We also select the hole and shaft size tolerances to be the same. Therefore  $t_H = t_F = t$  leading to

$$F_{max} = F_{min} + t$$

Using the minimum clearance formula

$$P_{min} = H_{min} - F_{max} = (25 - F_{max})$$

$$0.025 = 25 - F_{max} \rightarrow F_{max} = 24.975 \text{ mm}$$

Using the maximum clearance formula

$$P_{max} = H_{max} - F_{min}$$

$$0.06 = (25 + t) - (24.975 - t) \rightarrow t = 0.0175 \text{ mm}$$

The required size limits of the hole become

$$H_{min} = 25.000$$

$$H_{max} = 25.017$$

The required size limits of the shaft become

$$F_{max} = 24.975$$

$$F_{min} = 24.957$$

Note that the fourth digit of precision is dropped as an unnecessary level of precision. The following table shows that the closest preferred fit to the fit in this problem is the close running fit 25H8/f7. The largest clearance of 25H8/f7, however, exceeds the needed limit. The next rows in the table show how the fit clearance changes if we progressively change the tolerance IT values. As indicated in the table, the IT value change does not affect the tightest fit, only the loosest fit.

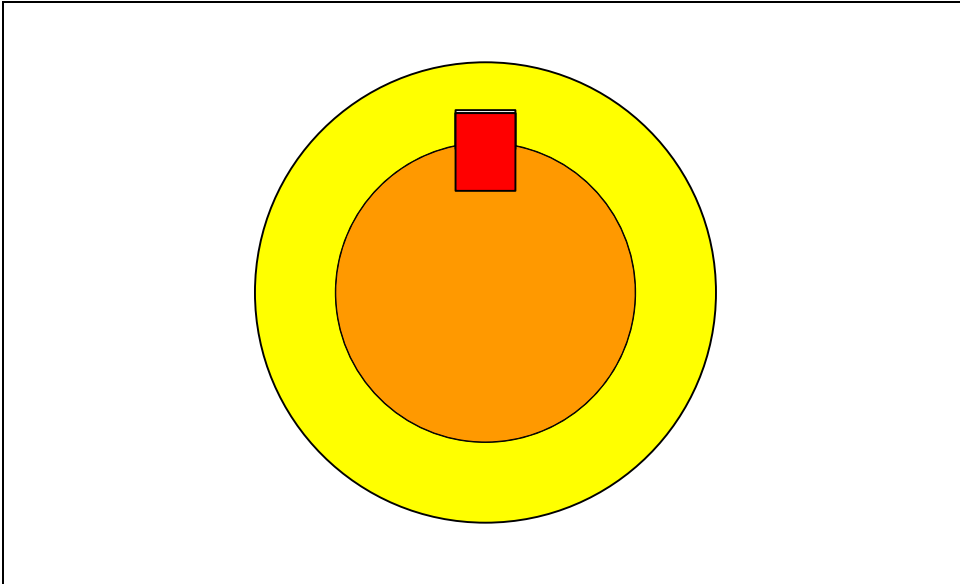
Fit	Minimum clearance	Maximum clearance
<b>This fit (required limits)</b>	<b>+0.020</b>	<b>+0.060</b>
25H8/f7	0.020	0.074
25H7/f7	0.020	0.062
25H7/f6	0.020	0.046

In this case, the performance of 25H7/f7 is closest to the required limits. Note that any possible manufacturing advantage in this specification is in the 25H7 limits and not in the 25f7 limits.

**Example-9** A gear is to be fixed to a 15-mm shaft using a Woodruff key. The nominal width of the Woodruff key is 5 mm and the width is manufactured to limits of  $5h9$ . The keyway on the shaft is recommended to have an  $N9$  tolerance zone. The keyway width

on the hub is recommended to have a *JS9* tolerance zone. Figure 6-19 shows the fit between these members. Determine:

- a) Which fit is the tighter fit (key and shaft or key and hub)?
- b) The fit limits (clearance or interference) values for key/shaft and key/hub fits.



**Figure 6-19.** Fit of a key to shaft and hub keyways

### Solution

**Part-a)** The *h9/N9* is a tighter transition fit than the *h9/JS9* fit. This means the key has a tighter fit in the shaft keyway than the hub keyway. A better assessment of these fits can be made by determining the fit limits.

**Part-b)** Using the LAF program we can determine the following

*5N9*: (4.97 – 5.00) mm.

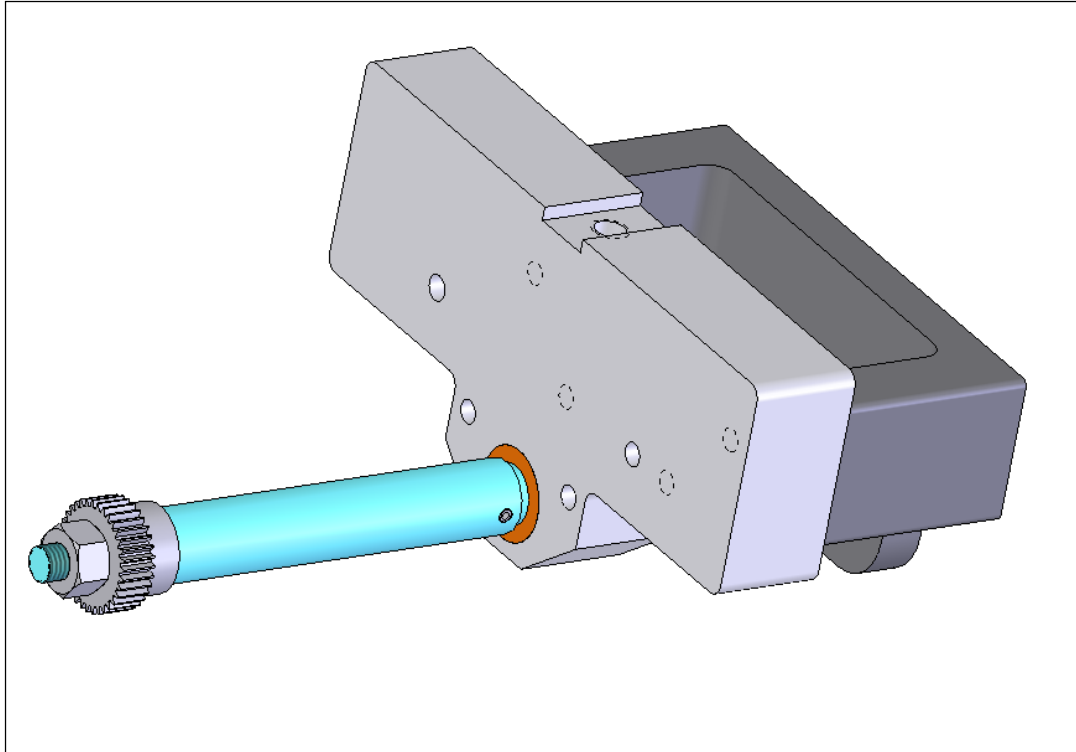
*5JS9*: (4.985 – 5.015) mm.

*5h9/N9* fit play or interference: -0.03 to +0.03 mm.

*5h9/JS9* fit play or interference: -0.015 to +0.045 mm.

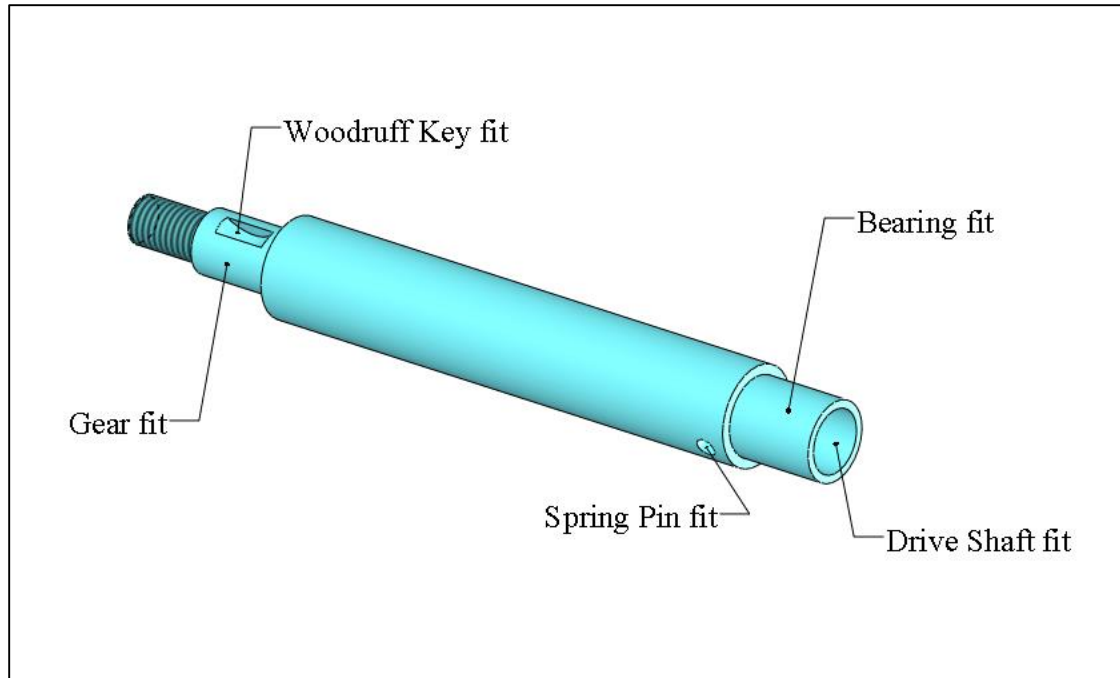
The *5h9/JS9* fit with a maximum play of 0.045 mm in the gear hub is looser than *5h9/N9* fit with a maximum play of 0.030 mm in the shaft.

**Example-10:** This is the extension shaft tolerancing problem that was presented earlier in this chapter. Figure 6-20 shows the extension shaft that is driven by a drive shaft that fits into one end of it and is fixed by a pin.



**Figure 6-20. Extension shaft assembly**

The drive shaft is intended to run at slow speeds and the bearing bore pressure (radial load) is small. The shaft's outer diameter fits a bushing. There is a gear fit on the open end of the shaft that is held in place by a standard Woodruff key. Figure 6-21 shows the precision fit features of the shaft. Select all the size tolerances of the identified features necessary to achieve the desired fits.



**Figure 6-21. The precision fit features of the extension shaft**

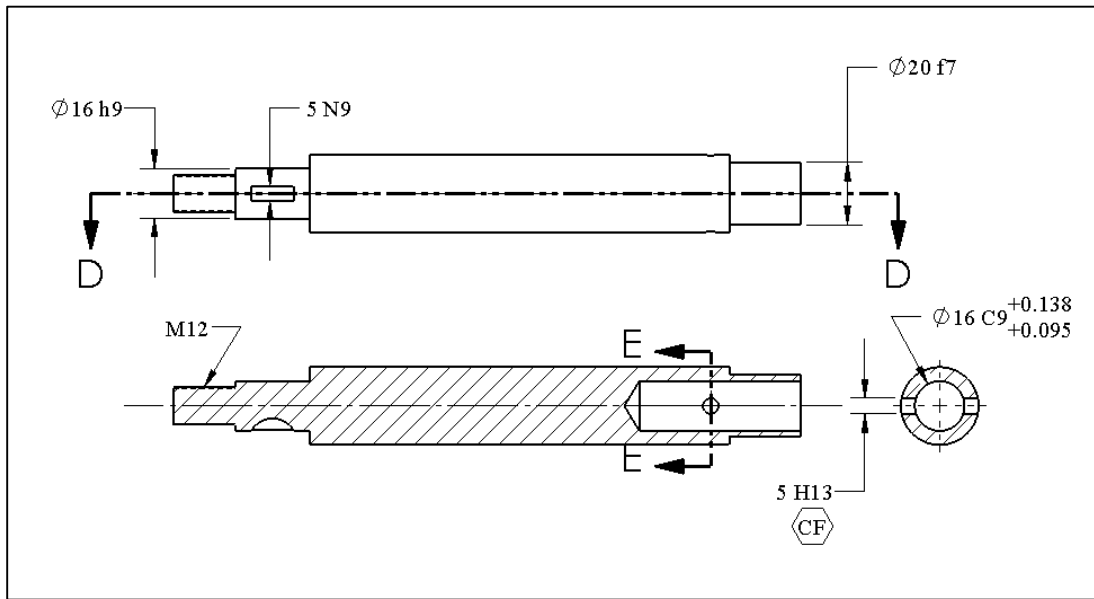
We will use the following basic size information:

- The OD of the extension shaft where the bearing fits is 20 mm
- The ID of the shaft where the drive shaft fits is 16 mm
- The shaft diameter where the gear fits is 16 mm
- The spring pin is 5 mm
- The Woodruff key width dimension limits is 5h9

**Solution:** There are five size limits to be determined:

- a) Bearing to shaft fit
- b) Drive shaft fit into the extension shaft hole
- c) Woodruff key fit
- d) Spring pin fit
- e) Gear fit

All of these fits are unconstrained fits except the fit of the drive shaft into the extension shaft hole. The reason for the constrained fit of the drive shaft is that the bearing fit prevents the extension shaft to freely align itself with the drive shaft. The final solution reflecting critical size tolerances is shown in Figure 6-22. The selected sizes for each fit are explained following the figure.



**Figure 6-22. The critical size tolerances of the extension shaft**

*The bearing fit:* The plain bearing fit to the shaft is chosen to be a close running fit. This is an adequate fit when speeds are low and the bearing is not intended to carry large radial loads. In addition, this close fit minimizes the radial runout at the gear end. Therefore the limits for this fit are selected as  $20H8$  for the bearing bore and  $20f7$  for the shaft.

*The drive shaft fit:* The drive shaft hole can be initially selected to have  $16C9$  size limits to provide enough clearance for the extension shaft to fit the drive shaft and the bearing simultaneously. Additional location control must be applied to assure the hole would fit the drive shaft. The details of this fit and location control statement will be explained in the chapter on location-constrained fits.

*Keyway fit:* Based on fit recommendations by the manufacturer, the shaft keyway requires  $N9$  size limits to have a tight fit to the key.

*Spring pin fit:* A 5-mm nominal size spring pin has been selected. The pin manufacturer recommends the fitting hole limits to be 5.0 - 5.2 mm in size. These limits are close to  $5H13$  which correspond to 5.00 - 5.18 mm. The box with CF letters, shown in the figure, indicates that the two pin holes are to be treated as if they were one continuous feature. CF stands for continuous feature.

*The gear fit:* The gear should slide in and out easily. The gear is fixed to the shaft using a key. The gear bore is assumed to have  $H$  size limits. A locational clearance fit ( $16H7/h6$ ) has a minimum clearance of zero allowing free assembly. The tolerances are small enough that the fit is precision and snug. However, the gear fit does not need to be so precise and so snug. We can relax the IT grades to reduce cost and yet have a

functional fit. The precision obtained using average turning process (IT9) would be adequate for this fit. Therefore, the shaft limits where the gear fits are selected to have  $16h9$  size limits.

**Example-11:** Determine the minimum temperature difference in degrees Celsius that is required to shrink fit two features on steel parts with a  $25H7/s6$  medium drive fit?

**Solution:** Thermal expansion can be used to change the size of features to achieve a shrink fit. The expansion per mm of diameter, or the thermal strain relationship is

$$\varepsilon_T = \alpha\Delta T$$

The change in feature diameter due to such a temperature change is

$$\Delta D = \alpha D\Delta T$$

where  $\alpha$  is the coefficient of thermal expansion. The maximum diametrical interference in this fit is 0.048 mm. The coefficient of thermal expansion for steel is  $10.8 \times 10^{-6}$  mm/mm per degrees Celsius. Therefore the temperature change needed is

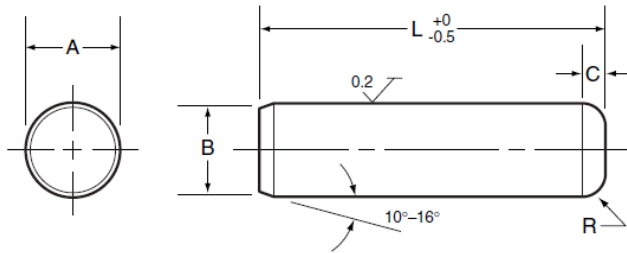
$$\Delta D = 0.048 = 10.8(10^{-6})(25)\Delta T \Rightarrow \Delta T = 178 \text{ degrees C}$$

A temperature differential of about 180 degrees Celsius would be sufficient.

### Exercise Problems

1. Use the LAF program and determine the size limits of a  $15f6$  shaft and a  $15H7$  hole. If these features fit together what is the resulting range of clearances or interferences?
2. What kind of preferred fits are adequate as an initial selection for the following applications?
  - i. A disk drive bearing sliding on a ground shaft.
  - ii. The ID of a ball bearing fitting a rotating shaft subject to heavy shock loading.
  - iii. The OD of a plain bearing fitting a stationary housing.
  - iv. The ID of a plain bearing and a shaft in a precision rotation application.
  - v. A dowel pin fitting tightly into a jig hole – the fit is rigid but removable.
  - vi. A gear that can be freely assembled on a shaft.
  - vii. A shaft collar used to fix the axial location of a pulley.
3. What is the size of the fit boundary associated with a hole having size limits of  $15H11$  and a straightness tolerance of 0.05 mm at MMC? What would be the theoretical size of a GO gage that would inspect the feature's straightness tolerance?
4. A disk drive guide rod has a  $3g6$  specification and is intended to have a sliding fit with a  $3H7$  bearing ID. The length of fit is 5 mm. What tolerance specification is appropriate for the rod such that the sliding fit can be achieved without requiring the rod to have unneeded precision?
5. The ID of a collar designed for a 12 mm shaft is between 12 mm and 12.013 mm. Determine the fitting shaft size limits for a performance similar to a free running fit.

6. Pick three of the 10 classes of preferred fits and find an actual example for them. You can find such examples in your gym, machine shop, automobile, labs, your kitchen or garage, or other ordinary places. Take pictures and explain why the selected fit matches the preferred fit you picked.
7. Search the internet for “Standard metric drill sizes” for drills up to 25 mm per ANSI/ASME B94.11M standard. Indicate the millimeter sizes and fractions that are available starting from the smallest (0.35 mm) size. Also search for tolerances that regular twist drills can hold in terms of IT grades.
8. Search the internet for typical reamer sizes (Metric sizes per DIN1420 H7) standard. Do the reamer sizes match the drill sizes? Also look for tolerances that reamers can hold in terms of IT grades.
9. Search the internet for the applications and standard metric sizes of dowel pins.



What are the main application of dowel pins? The following chart shows a set of standard metric sizes for dowel pins.

DIMENSIONS			
nominal size	A pin diameter		
	max.	min.	
3	3.008	3.003	
4	4.009	4.004	
5	5.009	5.004	
6	6.010	6.004	
8	8.012	8.006	
10	10.012	10.006	
12	12.013	12.007	
16	16.013	16.007	
20	20.014	20.008	
25	25.014	25.008	
All dimensions in millimeters.			

Do these size limits correspond to particular standard coded limits? If yes, specify the coded limits for each case.

10. Search the internet for standard ground shafting in metric sizes. The following is a list of precision hardened ground shafting from a supplier. The first column is the basic size in mm. The second and third columns are the tolerances in microns reducing the basic sizes for two different grades of precision. Do the limits in each column correspond to a particular standard coded size limits? If yes, what are the codes?

5	0-8	0-12
6	0-8	0-12
8	0-9	0-15
10	0-9	0-15
12	0-11	0-18
14	0-11	0-18
15	0-11	0-18
16	0-11	0-18
18	0-11	0-18
20	0-11	0-18
22	0-13	0-21
25	0-13	0-21

11. A supplier of rigid shaft couplings offers products with bore sizes up to 30 mm. The supplier also indicates that the bore size tolerances for all their couplings are between 0.00 and 0.03 mm over the nominal size. What IT grades are closest to the indicated tolerance for bore sizes ranging from 5 mm to 30 mm?

# Chapter 7

## Tolerance Design for Orientation-constrained Fits Between Two Parts

### 7.1. Overview

Orientation-constrained fits occur when the fitting features are subject to a constraint in orientation. Fit features are no longer free to center themselves for fit. For example, consider the simple fit between part<sub>1</sub> and part<sub>2</sub> in Figure 7-1. In this assembly, the two plates are intended to firmly contact on the seating surfaces while the stud fits inside the hole. The design requires that, after assembly, the two seating surfaces be in firm contact.

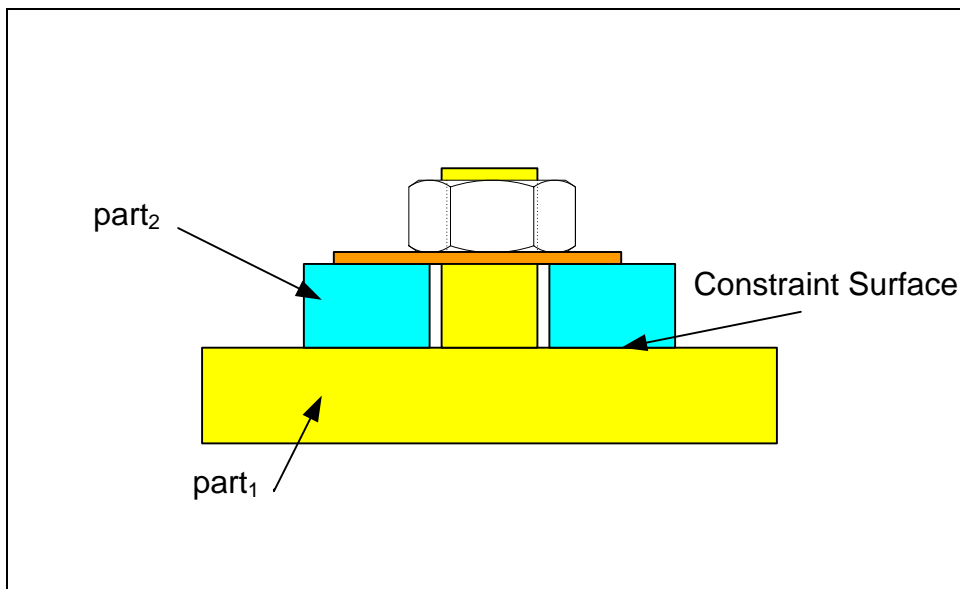
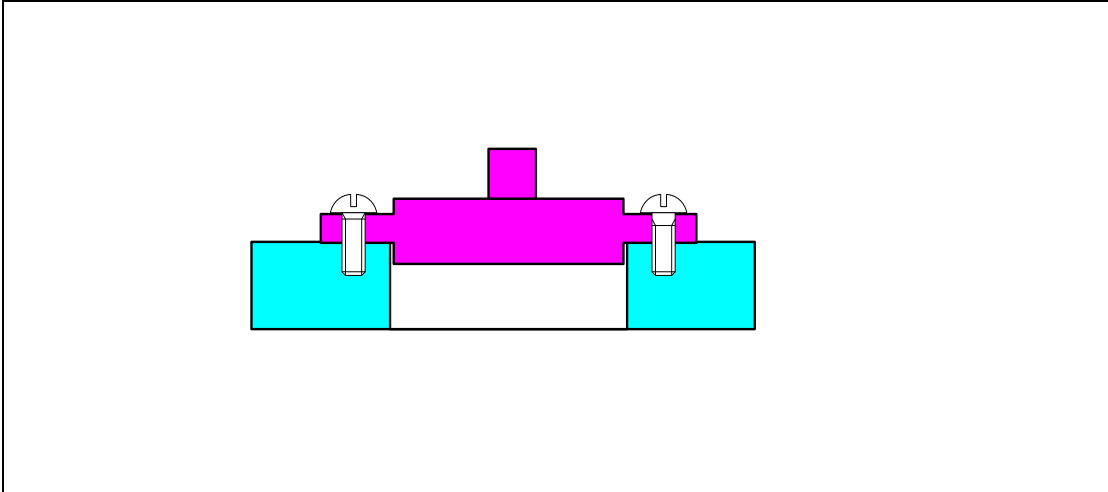


Figure 7-1. An example of an orientation-constrained fit

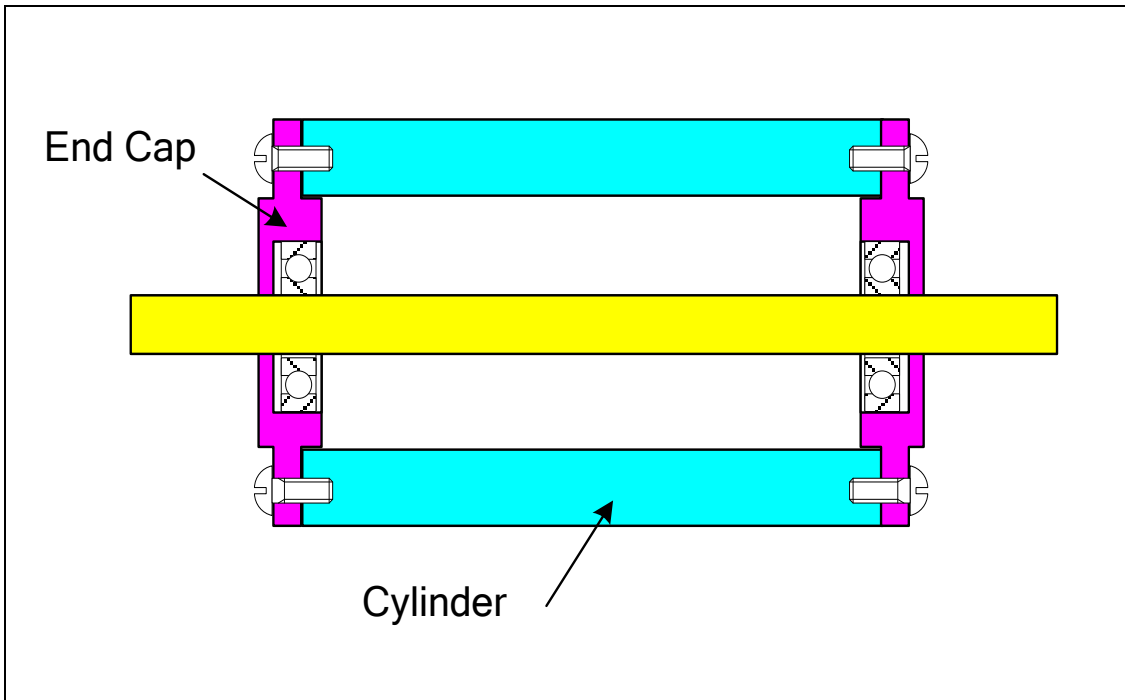
The constraint surface creates only one admissible orientation between the two fitting features. In this case, the constraint surface is the primary orienting surface between the two parts.

When the design intent is to orient two parts with respect to each other using a firm contact on two surfaces, the designer must set up the tolerances such that parts that pass the inspection would fit together while they rest on their contacting surfaces. A typical and practical example of an orientation constrained fit involves a precision fit between a stubby boss on one part and a hole in a mating part. The parts are often attached by threaded fasteners after the precision fit is achieved as shown in Figure-7-2.



**Figure 7-2. A common application of an orientation-constrained fit**

In this example the shallow boss is to fit the hole while the two seating surfaces make full contact. Figure 7-3 shows an example of a motor shaft and housing fit where two orientation-constrained fits are used at the two ends of a motor housing to keep the shaft properly aligned and centered. The shaft is supported by ball bearings.

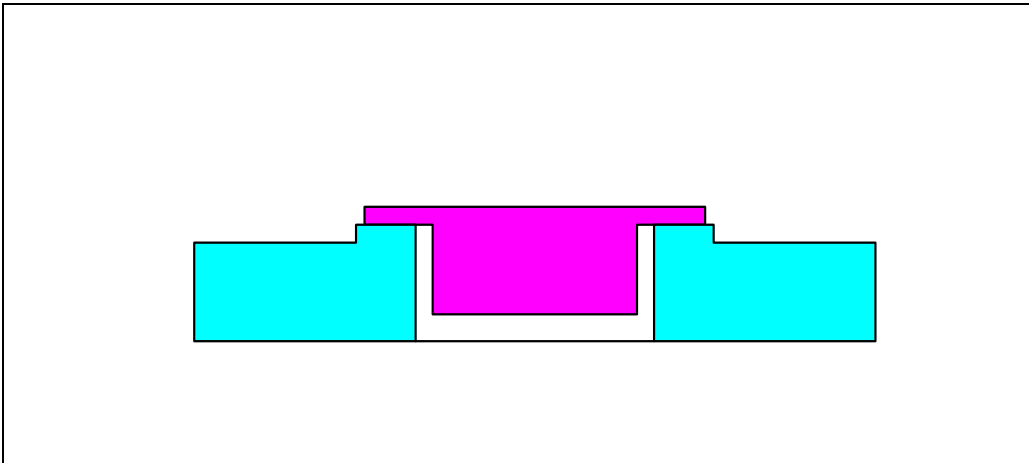


**Figure 7-3. A common application of an orientation-constrained fit**

## 7.2. The fit boundary and the theoretical gage

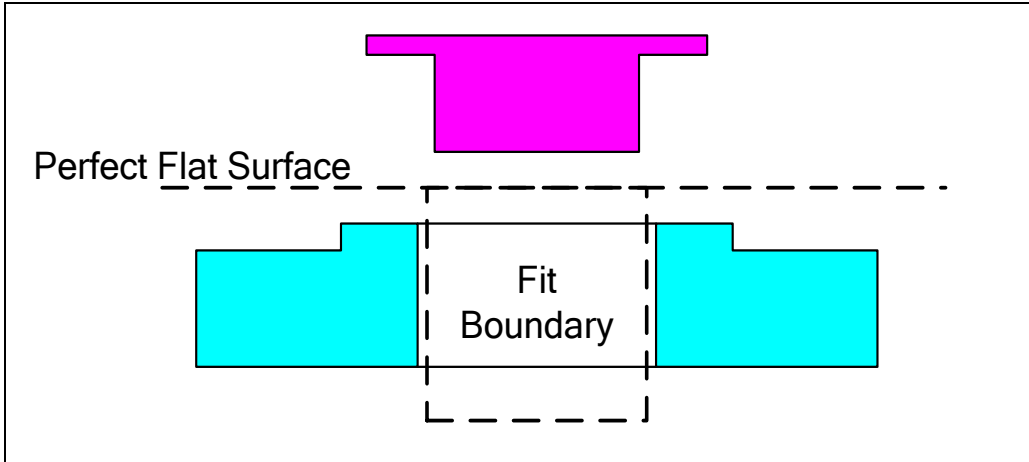
The designer's problem in orientation-constrained fits is similar to the unconstrained fits. The objective is to tolerance the fitting features such that they always fit together with an acceptable play. Unlike unconstrained fits in which the amount of play or interference was critical to the proper function of the fit, constrained fits usually work best when there is no or little play in the fit.

Consider the simplest case of a pin and a hole such as the one shown in Figure 7-4. The design intent is to precisely orient the two parts relative to one another using the seating surfaces. The fit features then center the two parts. Usually this kind of fit allows little fit play and is designed for precision orienting and locating of one part with respect to a mating part. In this figure, the fit play is exaggerated for illustration.



**Figure 7-4. A simple orientation-constrained fit**

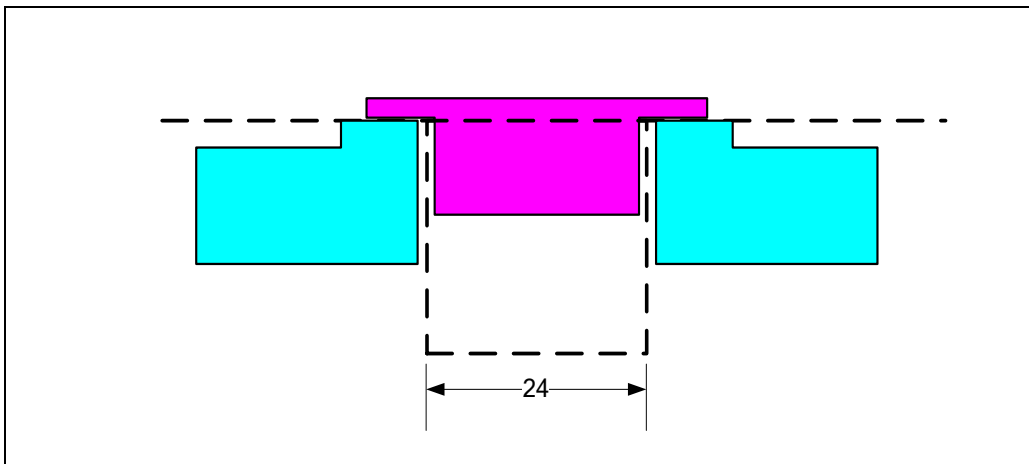
To assure a clearance fit, imagine a fit boundary such as the one shown as dashed lines in Figure 7-5.



**Figure 7-5.** Fit is assured when the pin fits inside the fit boundary while the seating surface aligns with the flat surface. Also, the hole fits outside the fit boundary when its seating surface aligns with the flat surface

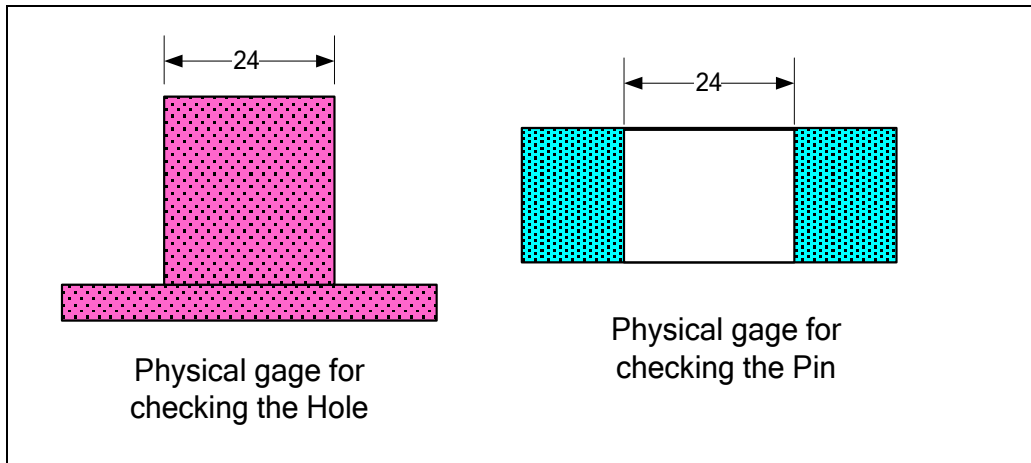
The pin must fit inside the fit boundary and the hole must fit outside of the same fit boundary while the seating surfaces are in full contact. To assure fit, a plane representing the seating surface should be added to the fit boundary to define the theoretical gage.

The logic of fit is simple and only involves checking each part separately against their theoretical gages. Figure 7-6 shows two acceptable parts passing the theoretical inspection successfully.



**Figure 7-6.** The theoretical gage drawn in dashed lines accepts both parts for fit

A physical hard gage can often be made to test the actual features for fit-related tolerance specifications as shown in Figure 7-7.



**Figure 7-7. Physical gages for checking the Pin and the Hole for fit**

The GDT statements that define the theoretical gage for orientation-constrained fits must describe the fit boundary sizes and identify the constraint surfaces to be used as datum simulators. The following text version of the tolerance statement captures the theoretical gage information for the pin:

- *Make the pin such that it would fit inside a 24-mm cylinder while the shoulder is resting on the datum plane*

This statement results in a 24-mm fit boundary and a datum plane perpendicular to it just like the dashed line geometry shown in Figure 7-6. For manufacturing purposes the above tolerance instruction is difficult to use. An alternative specification in terms of feature local sizes and a limit on deviation from perpendicularity is more helpful in manufacturing as these geometric precisions directly relate to process capabilities and can be measured during manufacturing with common inspection tools. We can use the following alternative description of the fit boundary:

- *Make the pin such that its maximum cross-section size would not exceed 24 mm. If the cross-section size is 24-mm, the feature must be perfectly perpendicular to the datum surface. When the cross-sectional size is smaller than 24-mm, the shaft axis can tilt by the difference between the actual size and the MMC size of 24 mm.*

Note that the deviation from perpendicularity is measured as a distance, not an angle, as shown in Figure 7-8. In this case the deviation from perfect perpendicularity is 0.3 mm.

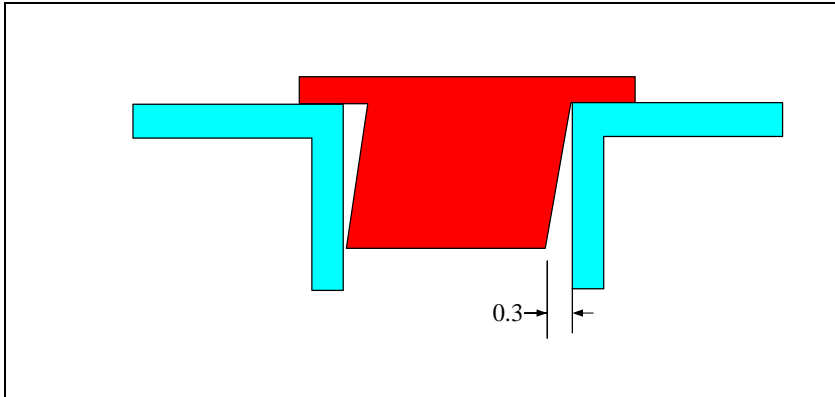


Figure 7-8. Deviation from perpendicularity is measured as a distance not an angle

As an example, the axis of a 23 mm pin can be slanted by as much as 1 mm and still fit inside the 24 mm boundary. The axis of a 20 mm pin can be slanted by as much as 4 mm and pass the tolerance statement as well. Obviously the above tolerance statement is only concerned with assuring fit without caring about maximum possible play in the fit. Another statement would be required to limit the maximum play by excluding pins that are too small. Adding a minimum size limit of 23 mm and abbreviating the text, the new tolerance statement requires the following two parts:

- *Make the pin such that its cross-section size would be between 23 and 24 mm.*
- *If the cross-section size is 24-mm (at MMC), then the feature axis must be perfectly perpendicular to the datum plane.*

In the second statement, it is understood by the manufacturing and inspection that what is required is a fit boundary of size 24 mm and the minimum local size is to be 23 mm. The extreme orientation of the pin that would be acceptable based on the tolerance description above is shown in Figure 7-9. Note that while the fit is always possible in manual assembly, it is not necessarily achievable if the fit is to be made by a pick and place robot. This is because humans can find the most favorable alignment for fit such that the pin would snap in place. A robot may not be able to find the best alignment for fit.

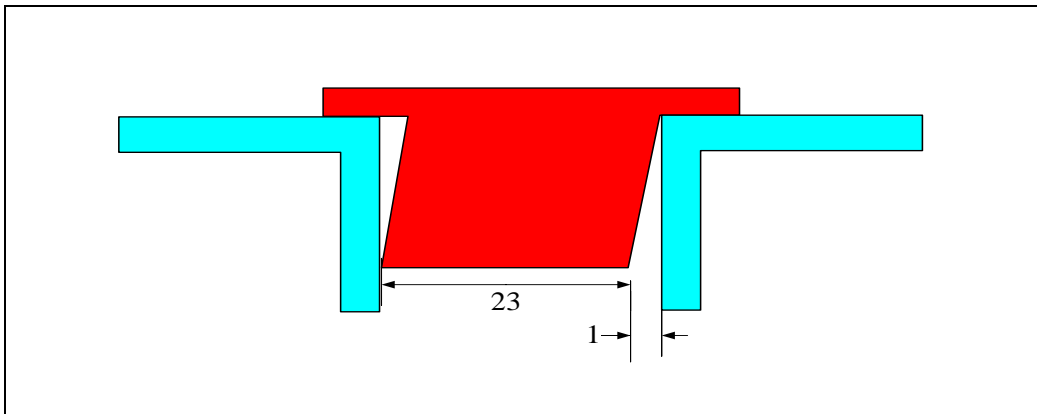
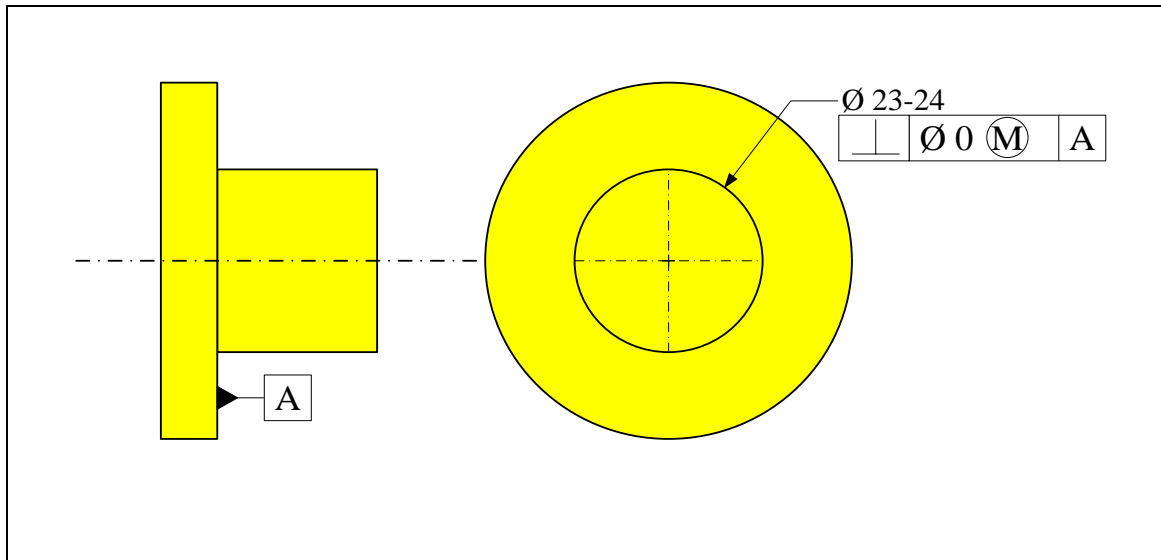


Figure 7-9. Maximum perpendicularity deviation for a 23-mm feature when fit boundary is 24-mm

The design engineer must now translate the tolerance requirements presented as text into standard geometric tolerancing symbols and place those symbols on the drawing. Figure 7-10 shows the way it must be indicated on the drawing:



**Figure 7-10. Defining a 24 mm fit boundary using the GDT standard format**

The manufacturing engineers read this statement as: “the feature cross-sectional size is to be between 23 and 24 mm. This feature is to be perpendicular to datum A to within 0 mm at MMC.”

The designer can make the fit boundary larger than the MMC size of the pin by using a non-zero perpendicularity for tolerance value. For example, to define a 25 mm fit boundary for a pin with 23-24 mm cross-sectional size limits, we must specify a 1 mm perpendicularity tolerance at MMC as shown in Figure 7-11.

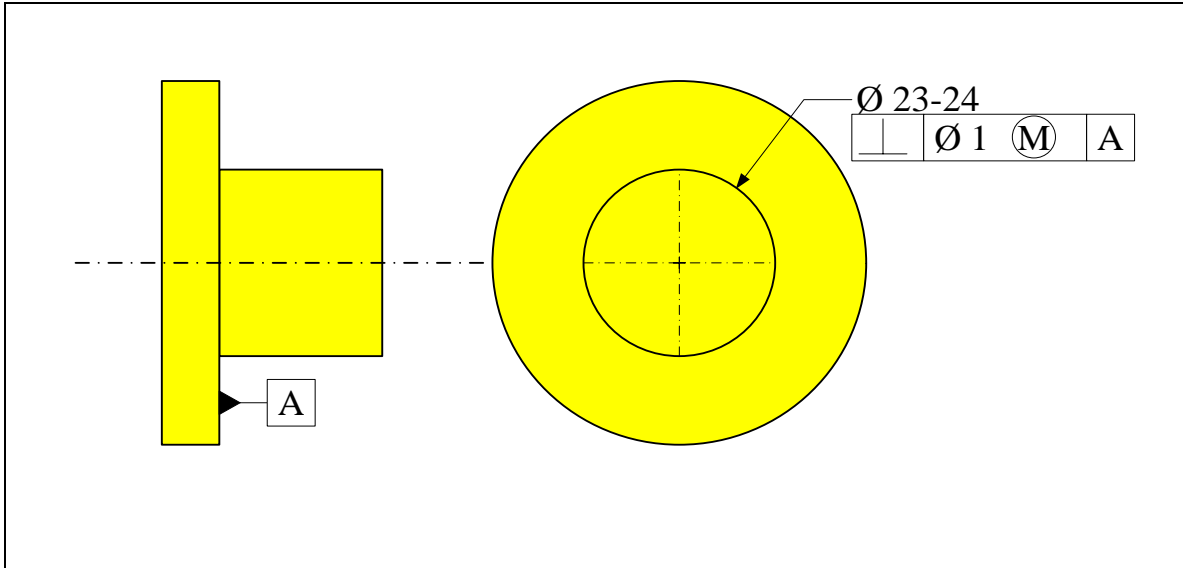


Figure 7-11. Defining a 25 mm fit boundary using the GDT standard format

In this case, a 24-mm pin is allowed to tilt 1 mm while a 23-mm pin can tilt 2 mm. For a pin, the size of the fit boundary is the sum of the geometric tolerance value and the MMC size of the pin. For a hole, the size of the fit boundary is the MMC size of the hole minus the geometric tolerance value.

The fit formulas developed for the unconstrained fits remain unchanged. The only difference is that the geometric tolerance changes from the straightness or flatness tolerance to perpendicularity tolerance. The minimum play formula is

$$P_{min} = (H_{min} - F_{max}) - (T_H + T_F)$$

To assure a zero-clearance fit in an orientation-constrained fit the sum of geometric tolerances applied to both features must be equal or smaller than the difference between the fit features MMC sizes

$$T_H + T_F \leq H_{min} - F_{max}$$

In this formula  $T_H$  and  $T_F$  are the perpendicularity tolerance values at MMC indicated in the tolerance statement. Also,  $H_{min}$  and  $F_{max}$  are the MMC sizes of the hole feature and the pin feature respectively.

In order to have at least a minimum play of  $P_{min}$  in the clearance fit, we can increase the difference between the fit boundaries of the mating features by adding a  $P_{min}$  to the hole fit boundary, or by subtracting a  $P_{min}$  from the pin fit boundary. The resulting tolerance relationship to assure a minimum play of  $P_{min}$  becomes

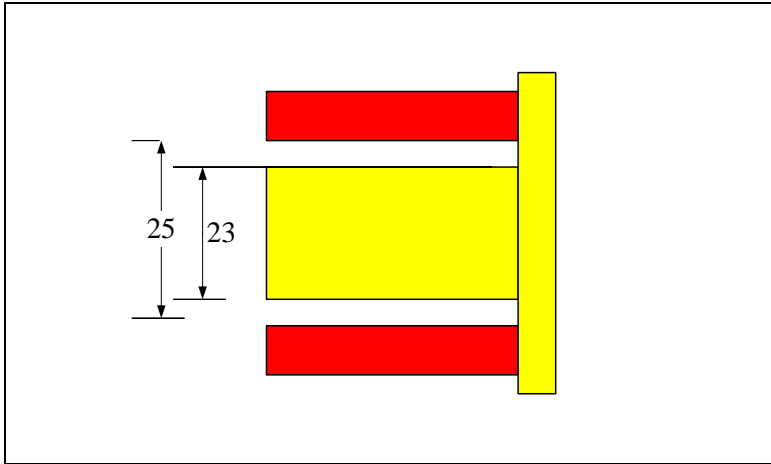
$$T_H + T_F \leq H_{min} - F_{max} - P_{min}$$

In the case of unconstrained precision fits the requirement for a minimum play was critical to the function of the joint in many applications. In the case of orientation-constrained fits or location-constrained fits, the need to have an assured minimum clearance is rare. In most applications involving constrained fits, the objective is for the features to simply fit together with as little play as possible.

The maximum play in a fit occurs when the two fitting features are made at their least material condition and are at perfect orientation relative to their datum surfaces. The maximum play formula based on LMC sizes is

$$P_{max} = H_{max} - F_{min}$$

Where  $H_{max}$  and  $F_{min}$  are the LMC hole and pin feature sizes respectively. Figure 7-12 shows the condition leading to maximum play for a 24-25 mm hole fitting a 23-24 mm pin.



**Figure 7-12. Perfect-perpendicularity at LMC leads to maximum play in a fit**

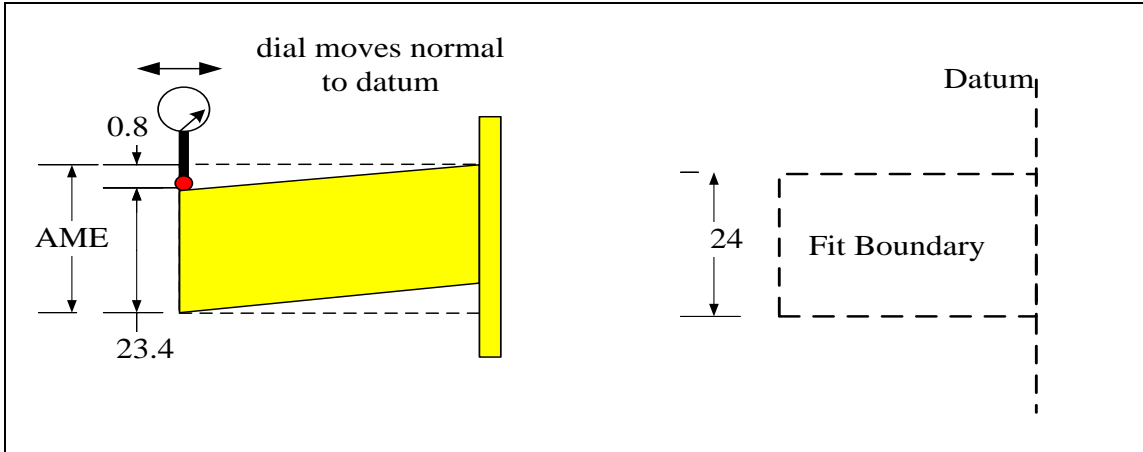
We can also write the maximum play formula in terms of tolerances of size and orientation as

$$P_{max} = t_H + t_F + T_H + T_F + P_{min}$$

Where  $t_H$  and  $t_F$  are the size tolerances of the hole and pin respectively. Note that in order to minimize the play we should use the smallest tolerances of size and orientation and also set up the fit with a zero minimum play.

### **7.3. A word on inspection**

Hard gaging is the direct method of checking all fit-related tolerance statements but if physical gaging is not feasible, the features can be inspected using other measurement tools. The inspection procedure attempts to determine whether the combination of cross-section size and out-of-perpendicularity would allow a feature to remain within its fit boundary. Figure 7-13 shows the situation for a 24-mm fit boundary where the size limits are 23-24 mm and the perpendicularity tolerance is zero at MMC.

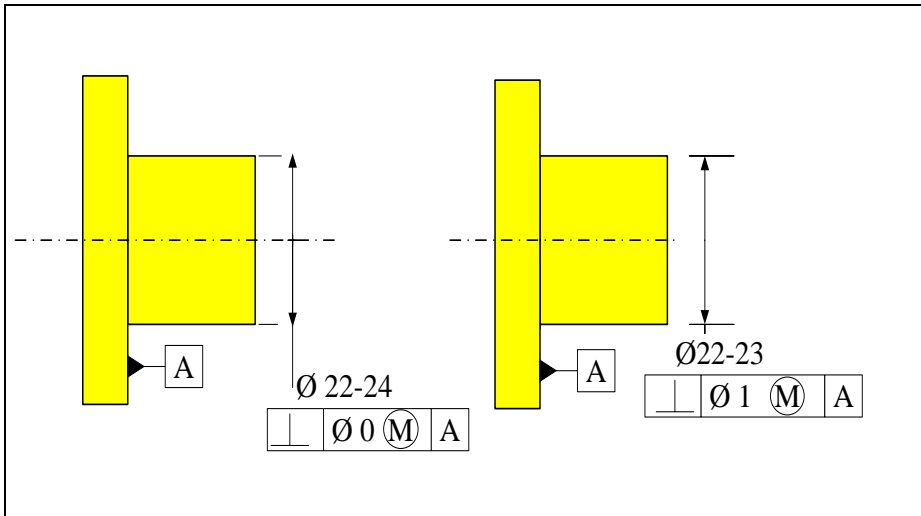


**Figure 7-13.** A dial indicator readout and the local size determine whether a feature violates the fit boundary

The verification is a simple geometry problem. Here, the combined effect of feature size and its axis out-of-perpendicularity exceeds the fit boundary by 0.2 mm. The combination of measured size and measured axis tilt defines a boundary similar to the fit boundary but with a size that just fits the feature. This measured boundary is an equivalent perfect-form representation of the actual feature for fit purposes. The formal name of this perfect-form boundary is *orientation-constrained actual mating envelope* or *orientation-constrained AME* of the feature. In the example shown in Figure 7-13, the size of the orientation-constrained AME for the shaft feature is 24.2 mm. The size of the unconstrained AME is slightly less than 23.4 mm.

#### **7.4. MMC boundary as fit boundary**

In the chapter on unconstrained fits it was argued that, when possible, the use of the MMC boundary as the fit boundary would be the best choice. That argument is also valid for the case of orientation-constrained fits and tolerance of perpendicularity. For example, consider the two options for defining a fit boundary of size 24 mm as shown in Figure 7-14.



**Figure 7-14. An example of an orientation-constrained fit**

The two features perform similarly in their ability to fit a mating feature because both have the same size fit boundary. The two features also have the same LMC sizes so they perform similarly in their potential maximum play performance. The specification on the right side of the figure that allows 1-mm perpendicularity at MMC is inferior to the specification with zero perpendicularity tolerance. This is because the statement with 1-mm perpendicularity tolerance does not accept a feature that is 23.5 mm even when the feature is perfectly perpendicular to datum-A and easily fits inside the 24 mm fit boundary. This means that in a fit situation, a non-zero geometric tolerance can exclude functionally acceptable parts. The use of zero geometric tolerance provides the widest manufacturing tolerances for the same fit performance. For fit purposes, zero orientation option makes the variations in size and orientation interchangeable both ways. A size close to LMC leaves maximum tolerance for orientation and a nearly perfect orientation leaves maximum tolerance for size.

To define the MMC boundary as the fit boundary requires the geometric tolerance value at MMC to be zero. This form of specification combines the tolerance of size and the tolerances of orientation into a wider tolerance of size. The fit formula when zero orientation tolerance is used for both fitting features becomes

$$H_{0min} - F_{0max} \geq 0$$

Setting up orientation-constrained fits with a zero geometric tolerance option is also simple and leads to economic advantages. For example, consider an orientation-constrained fit for a pair of features with the following requirements:

- Nominal size: 15 mm
- Minimum play 0 mm
- Maximum play 0.1 mm

The size limits for the features can be easily found by dividing the maximum play between the hole and the pin features. For example, dividing the 0.1 mm equally between the two features leads to size tolerance of 0.05 mm for both features. The pin

feature size limits would then become (14.95 – 15.00) and the hole limits would become (15.00 – 15.05). Both features border the basic size of 15 mm with holes slightly larger than the basic size (similar to *H*-class offset) and pins slightly smaller than the basic size (similar to *h*-class offsets). We have already seen in Chapter-6 that these types of size limits are economically preferred, especially when nominal sizes are selected from the list of preferred sizes or available standard sizes.

A zero orientation tolerance at MMC is often implied with standard parts. For example, a standard bolt with a maximum size of 10 mm is implied to have zero perpendicularity tolerance at the maximum size of 10 mm with respect to the seating shoulder of the bolt. This means the bolt with fit a 10 mm hole while the bolt head is firmly seated.

### 7.5. Situations where MMC modified tolerances cannot be used

When the size of a feature needs to be controlled with precision for any reason, the size tolerance must be specified as needed. In such cases the size tolerance should not be expanded to include the orientation tolerance. A common example is when a hole feature accepts a press-fit insert as shown in Figure 7-15.

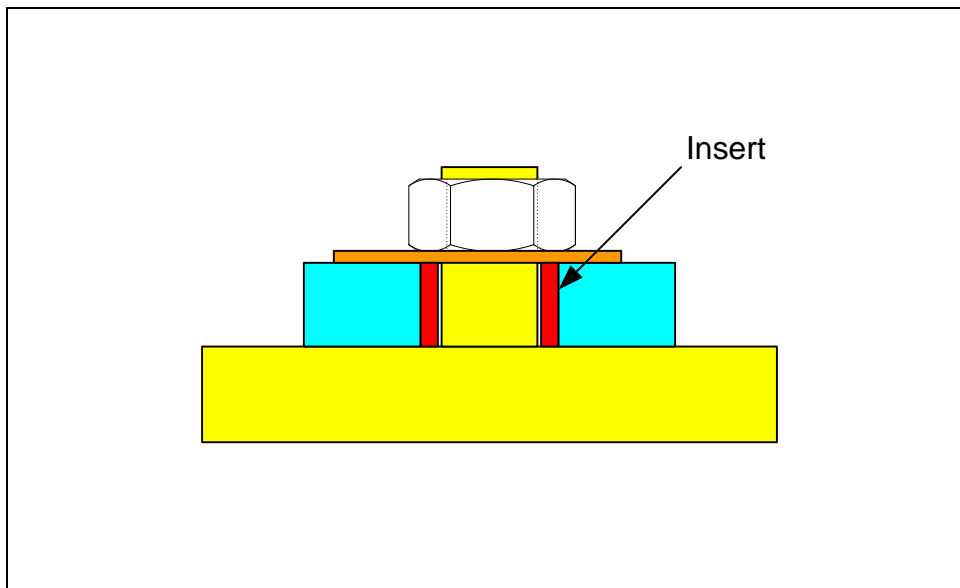
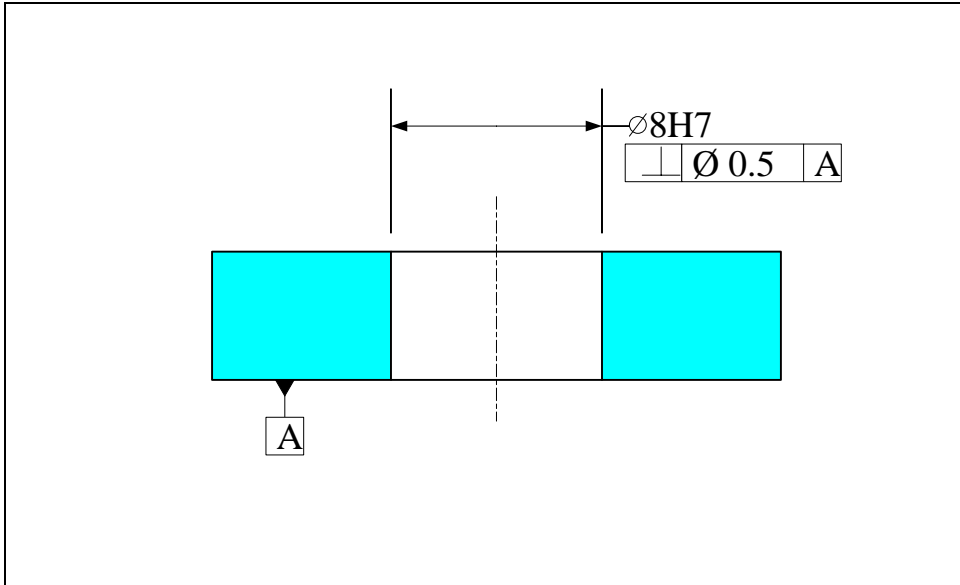


Figure 7-15. The hole feature in the plate must have size limits for interference fit to the insert

In this situation, the hole in the plate must have a precise size tolerance in order to have the required light interference fit. When the hole is toleranced for fit, its size and orientation tolerances must be specified separately without MMC qualification. This is shown in Figure 7-16.

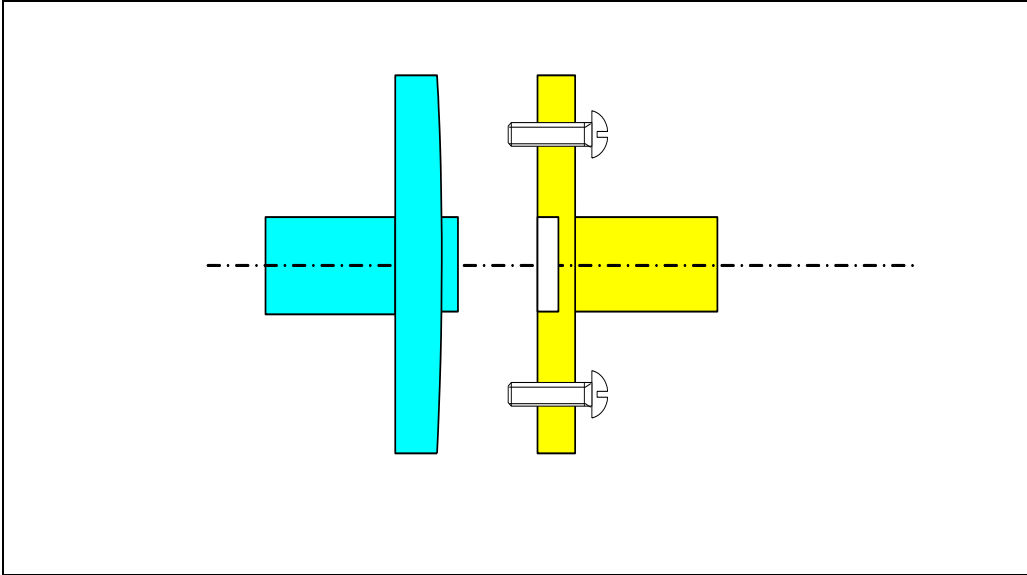


**Figure 7-16. Tolerancing of the hole feature for fit cannot use the zero perpendicularity format**

Note that this assembly involves three parts and we can no longer check the fit using fit boundary method. The methods for checking the fit of multipart assemblies will be presented in Chapter-11.

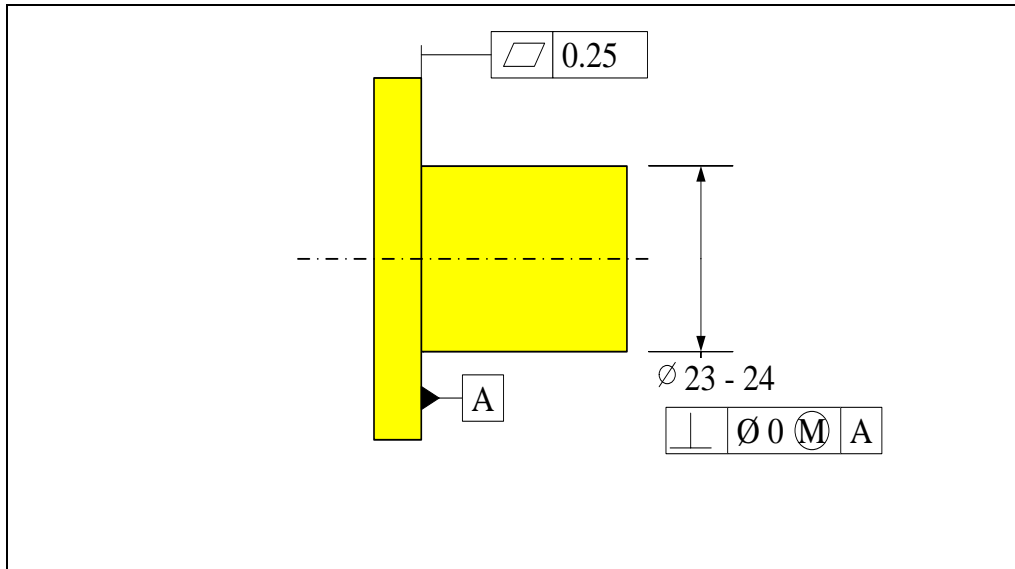
## **7.6. Datum feature flatness**

The objective of an orientation-constrained fit is to accurately fix the relative orientation of two parts and the datum features serve this purpose. If either of the datum features is not flat enough to prevent rocking, the final orientation relationship between the two parts becomes unpredictable and subject to the manner of final assembly. For example, in Figure 7-17 the seating datum surface of the part on the left is not flat enough and as a result the contact is subject to rocking. The final relative orientation between the two parts becomes dependent on which screw is tightened first. While the fit can be accomplished, the important relationship, which is the relative orientation between the two parts, becomes unpredictable. This can create misalignments that would compromise the function of the assembly or the fit of other parts in multipart fits.



**Figure 7-17. Uneven contact surfaces can create unpredictable results**

Applying sufficient flatness control is the method of preventing or reducing the possibility of rocking. In all orientation-constrained fits, the flatness of the datum surface must be controlled to the extent required to prevent rocking. An example of specification is shown in Figure 7-18.



**Figure 7-18. Adequate flatness control is necessary on all contact surfaces**

In some cases a small amount of rocking may not lead to adverse consequences. However, when the datum surfaces are used in precision applications, any rocking would be unacceptable. Such datum surfaces on typical machine parts must be finish milled or made with a process that can create a surface comparable to a finish milled surface.

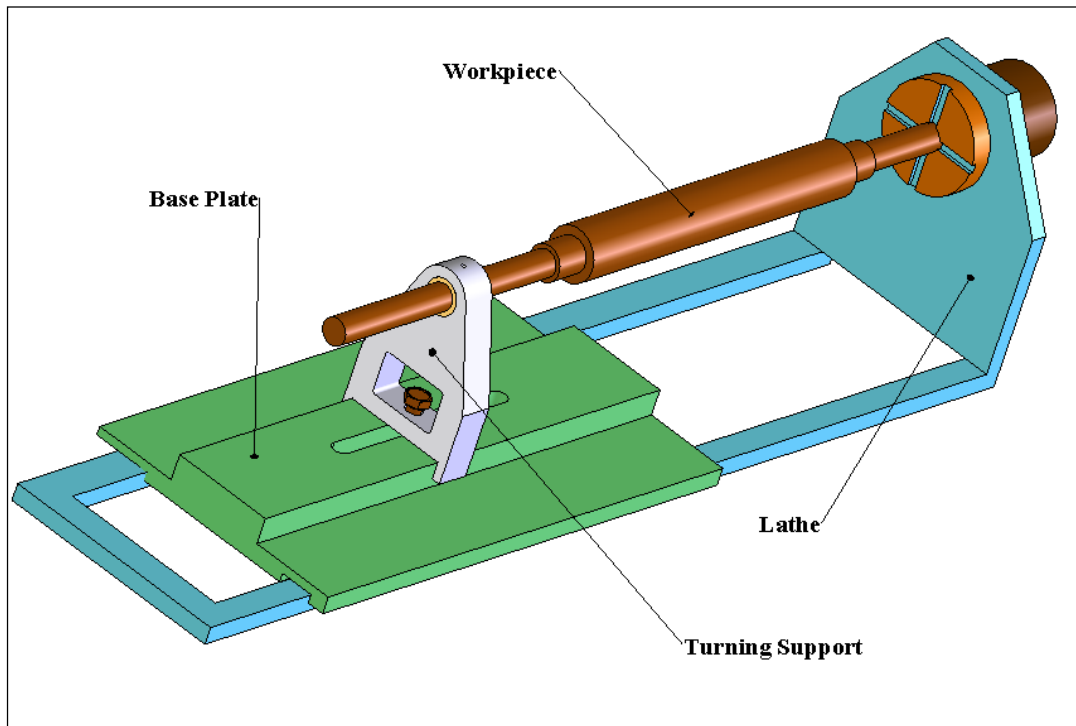
When large areas are to be used as orienting datums, it is best to create raised pads that would reduce the possibility of rocking while at the same time reduce the cost of machining. Figure 7-19 shows an example for the helical gearbox presented before.



**Figure 7-19.** Raised and machined surfaces are common in the design of cast parts

Note that the four mounting surfaces of the gearbox housing have raised surfaces which are milled to create a non-rocking support. The top surface of the housing, on the other hand, does not employ raised surfaces because it is used for sealing purposes.

**Example-1:** Figure 7-20 shows the turning support assembly along with a representation of a lathe machine and a part. The turning support assembly is an attachment to a lathe machine that provides additional support to a long part in the turning process. The function of turning support is similar to the lathe tail stock but the turning support can be positioned to support the part in the middle rather than the end of the part. Custom insert sizes can be made to adapt the turning support to various part sizes.



**Figure 7-20. Turning support assembly**

The fit to be specified is between the base plate rail and the turning support slot. We need to dimension and tolerance the slot and rail features in turning support and base plate for a fit with as little play as possible. The basic size of the slot is 76 mm and we know that a finish milling process would create adequate precision for these parts. After specifying the tolerances we like to calculate the maximum play in the slot/rail fit.

**Solution:** The milling process can hold a total combined size and perpendicularity tolerance of 0.12 mm for this 76 mm feature. Using zero geometric tolerances and equal tolerances for the slot and rail, the size limits of the slot becomes 76 (-0, +0.12) mm and the size limits of the rail becomes 76 (-0.12, +0) mm. The maximum play when zero geometric tolerances are used becomes the sum of size tolerances

$$P_{max} = (76 + 0.12) - (76 - 0.12) = 0.24$$

To complete the tolerance requirements for this fit, we need to apply a flatness control to the sliding datum surface. The surface must be sufficiently flat to assure firm seating and to prevent rocking. For a milling process, a flatness of 0.025 mm can be expected for the sliding surface of the slot feature and a flatness of 0.05 mm can be expected for the rail feature. Figure 7-21 shows the final tolerance statements for the turning support necessary for the fit to the base plate.

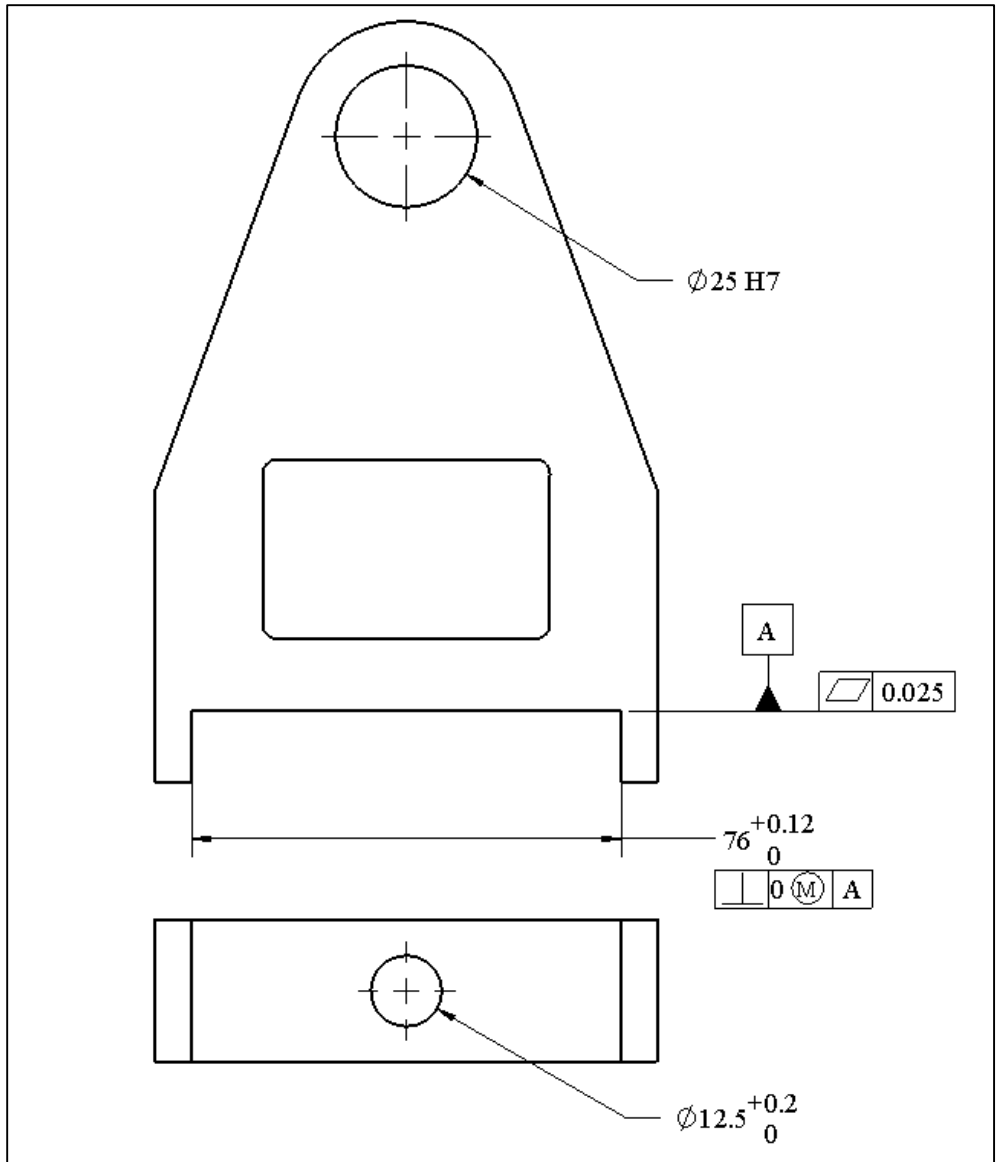


Figure 7-21. Tolerance of slot feature for an orientation-constrained fit

Figure 7-22 shows the final tolerance statements for the base plate necessary for the fit of the slot and rail. Since the length of fit is smaller than the length of the base plate, the perpendicularity tolerance can be specified to be per fit length.

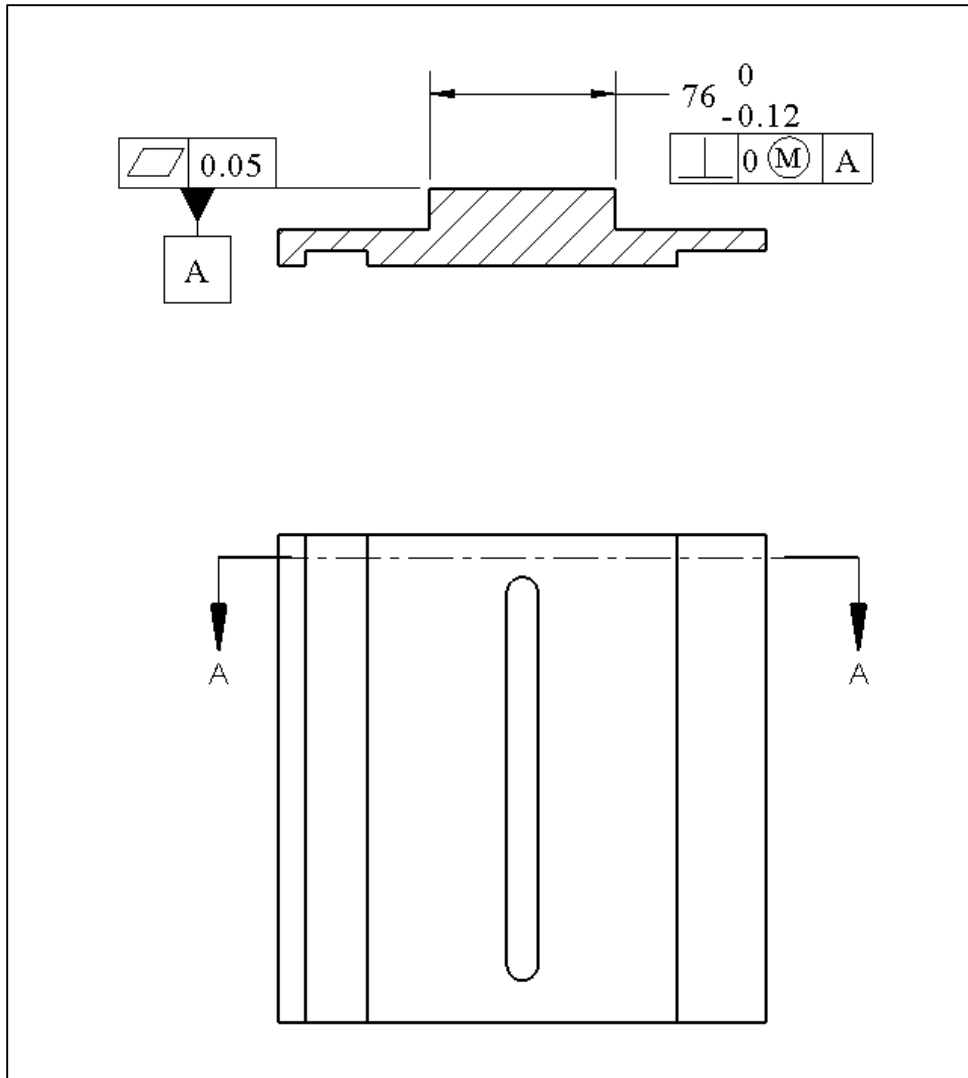


Figure 7-22. Tolerance of rail feature for an orientation-constrained fit

One common question when setting up orientation-constrained fits is whether it is necessary to have additional form control for fit features. This question is discussed in the next section.

### 7.7. Is it necessary to specify axis straightness?

An orientation control statement for fit defines a theoretical gage that would guarantee fit when each of the two mating features fit their theoretical gages. Therefore, for fit purposes, there is no need to control the feature axis straightness (for cylindrical features) or center plane flatness (for width features) separately. However, if no straightness control is specified, the feature straightness is automatically controlled because of Rule#1 which requires a zero straightness tolerance at MMC. This automatic straightness control is not needed in orientation-constrained fits and subsequently the cost of manufacturing such features may increase unnecessarily. For example, consider the pin in Figure 7-23.

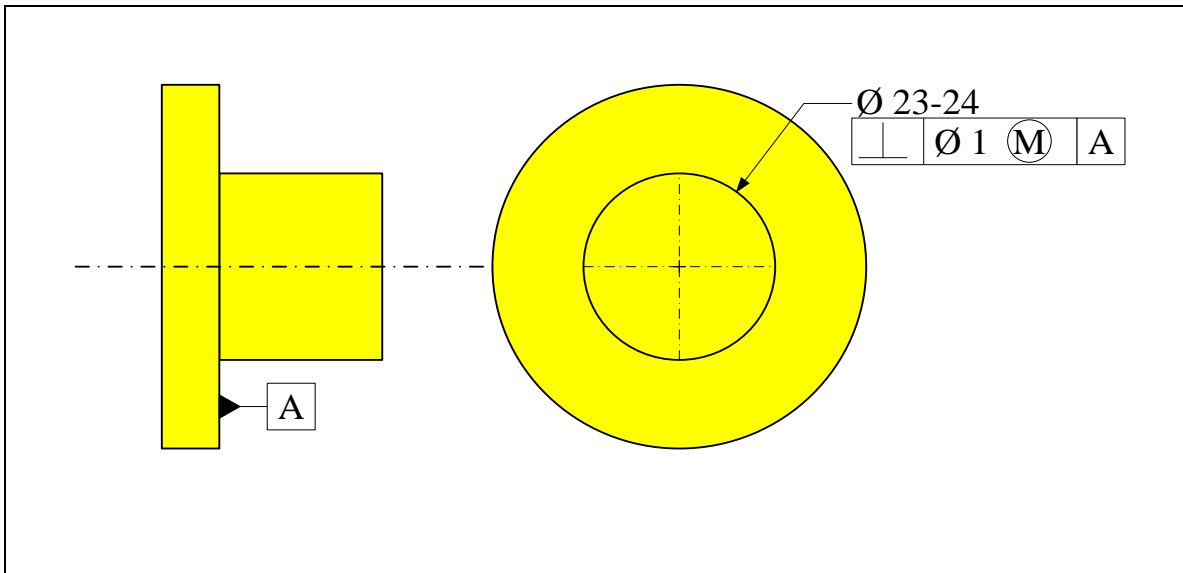


Figure 7-23. A feature set up for an orientation-constrained fit

In this example, if the pin feature is made at 24 mm (its MMC size), it can tilt as much as 1 mm and still fit inside the fit boundary of 25 mm. The pin may instead bend as much as 1 mm and still fit inside the gage. However, Rule#1 prevents any bending when the feature is 24 mm in size or at MMC. The result is the rejection of a perfectly functional feature due to the default straightness tolerance requirement of Rule#1. The automatic application of Rule#1 in this case is unnecessary.

To prevent the automatic application of zero straightness at MMC, the design engineer can use the *independency symbol* following the size tolerance as shown in Figure 7-24. With the independency symbol, the 24mm features can tilt or bend 1 mm as the requirement of perfect straightness at MMC no longer applies.

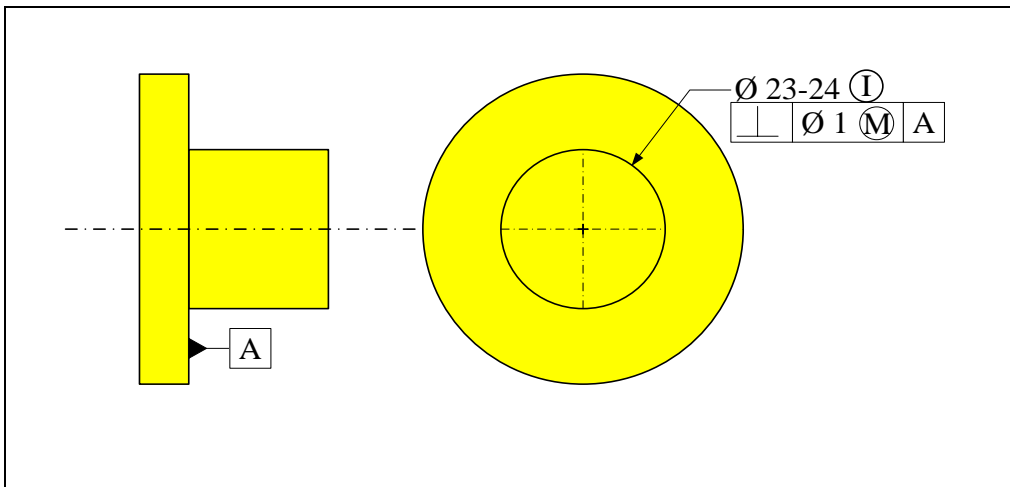
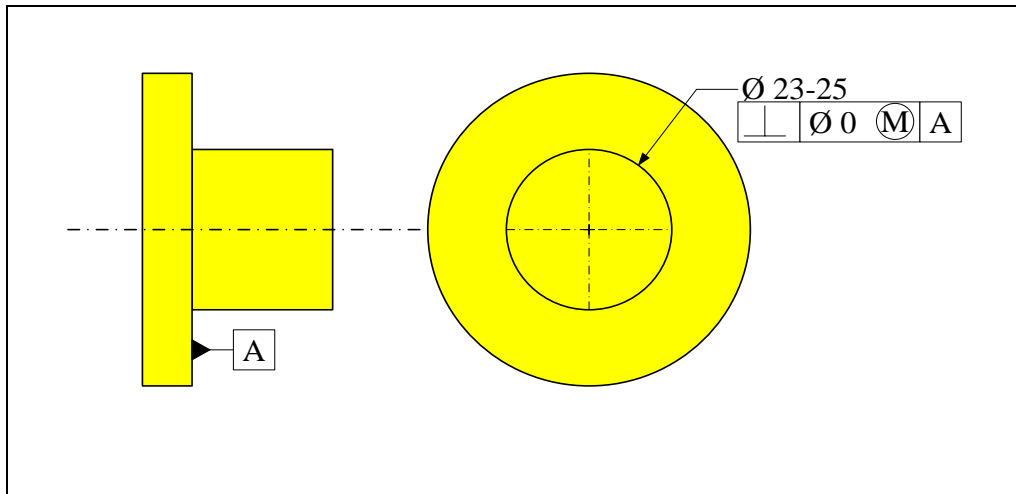


Figure 7-24. With the independency symbol the feature need not have perfect straightness at MMC

Fortunately, when we use zero-geometric tolerancing at MMC method, there is no need to use the independency symbol. Consider the equivalent zero-perpendicularity tolerance version of the pin shown in Figure 7-25.



**Figure 7-25.** There is no need for the independency symbol when zero geometric tolerance at MMC is used

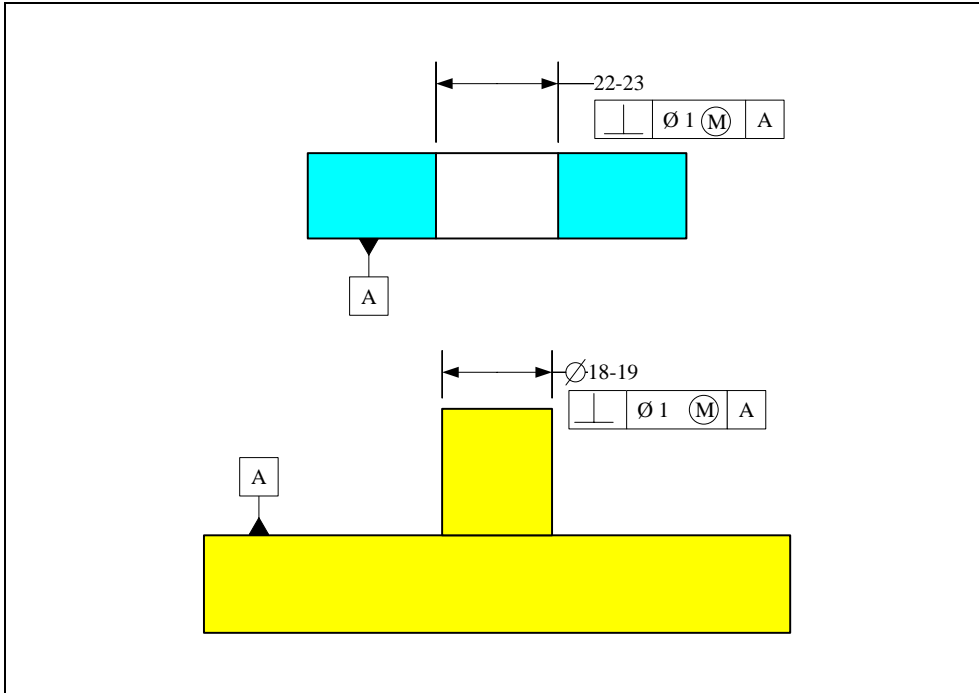
In this case, a pin made at MMC (25 mm) needs to be perfect in both orientation and straightness. If the feature is made at 24mm, then it can bend 1 mm or it can tilt 1 mm.

## 7.8. Defining a fit boundary without the $\textcircled{M}$ modifier

Fit boundaries can also be defined using regardless of feature size (RFS) tolerance statements. This means the tolerance values are not followed by a material condition modifier like  $\textcircled{M}$ . This practice is necessary in cases where the feature size is to be precisely controlled for a different reason. The discussion presented on this subject in Chapter-5 on unconstrained fits is also valid for orientation-constrained fits. There is no difference between minimum play performance of an orientation-constrained fit whether it is called out at MMC or RFS. The only difference is that the MMC specification allows more orientation deviation when the feature is closer to its LMC limits providing a clear manufacturing advantage.

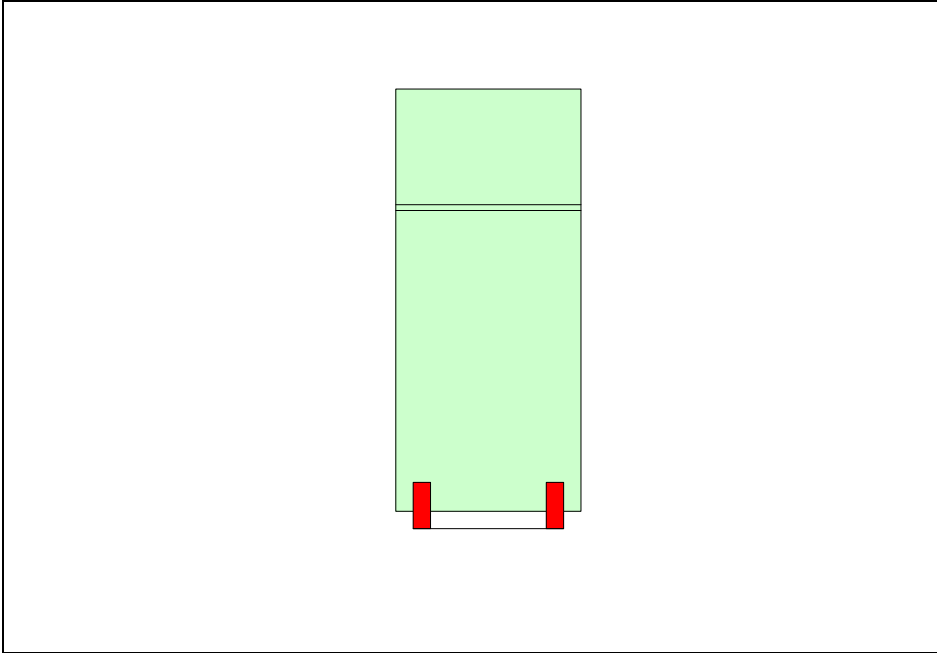
### Exercise Problems

1. Consider the orientation-constrained fit situation shown in Figure 7-26.



**Figure 7-26. A simple orientation-constrained fit**

- a) Using your CAD system model both parts with dimensions that result in worst-case condition for fit. For example, the pin size would be at the MMC size of 19 mm plus 1 mm allowance for orientation. Create an assembly of the two parts and check for free assembly. What is the play in the CAD assembly model?
  - b) Model the parts with dimensions leading to the maximum play in the fit. Create an assembly and determine the maximum play in the fit?
  - c) Model the parts and answer a) and b) when the RFS specifications are used for both features instead of MMC.
2. Consider the refrigerator example shown in Chapter-1 to illustrate the advantages of gage-building geometric tolerances to just using dimension limits. Figure 7-27 shows the refrigerator.



**Figure 7-27. The refrigerator and the doorway**

Suppose the doorway width is exactly 835 mm and its form and orientation with respect to the floor are perfect.

- a) Write a set of instructions using length and angle measurements to decide whether the refrigerator would pass through the door opening. Show the results for an example by making up some measurement data.
3. Find an actual example of an orientation-constrained fit. You can find such examples in your gym, machine shop, automobile, labs, your kitchen or garage, or other ordinary places. Take pictures and explain why the fit represents an orientation-constrained fit.

# Chapter 8

## Tolerance Design for Location-constrained Fits Between Two Parts

### 8.1. Overview

Location-constrained fits are the most common type of fit between two parts. In location-constrained fits a feature's location as well as orientation is constrained with respect to a datum frame. Figure 8-1 shows an example of a simple location-constrained fit involving a single fit feature, a primary orienting datum surface, and a secondary orienting and locating datum surface.

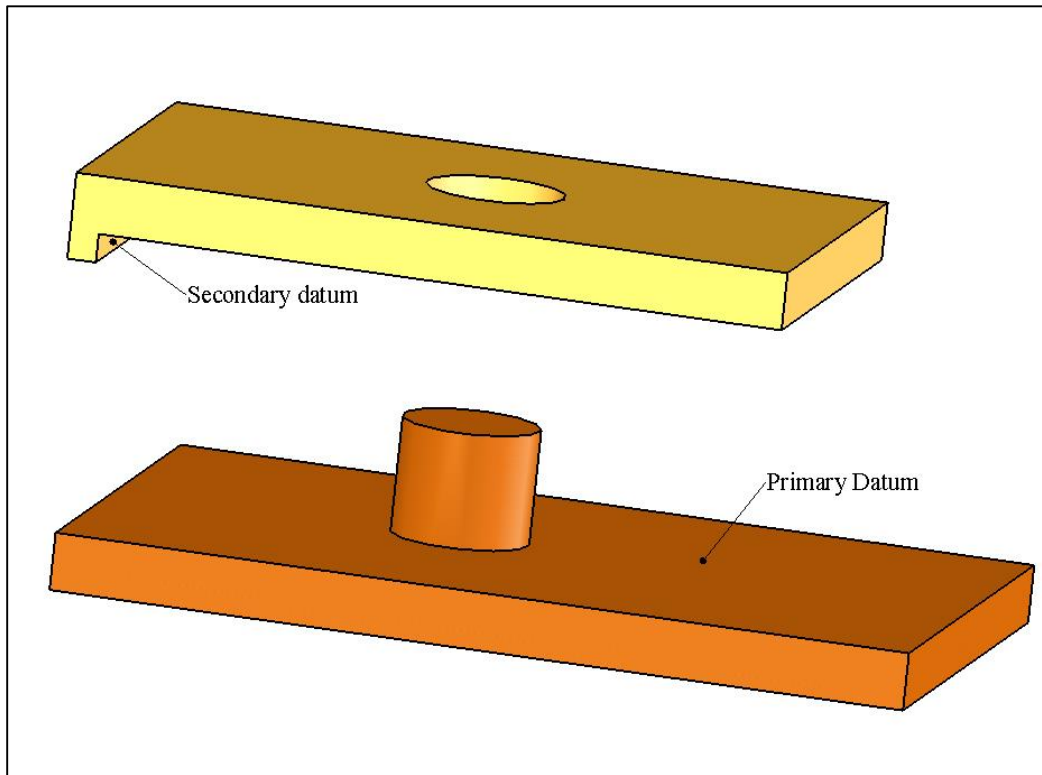


Figure 8-1. An example of a location-constrained fit

The relative orientation of the two parts is constrained by a planar seating surface. This seating surface is the *primary orienting/locating datum surface* (or *primary datum*). The other contacting surface is the *secondary orienting/locating surface* (or *secondary datum*). The secondary datum creates additional constraint between the two parts. With these two datum features in contact, the two parts can still slide with respect to each other and are not completely fixed together. In many applications, a third datum surface is used to completely fix the two parts with respect to each other. Figure 8-2 shows the 2D view of the assembly.

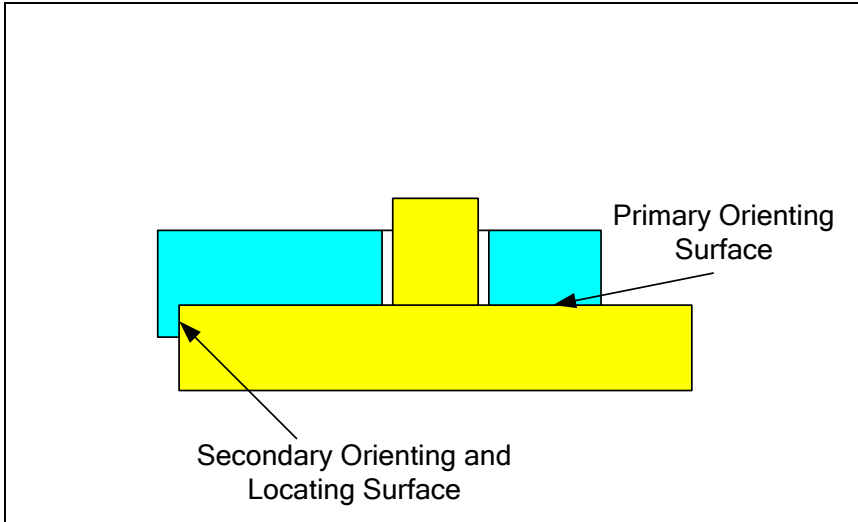


Figure 8-2. An example of a location-constrained fit in 2D view

The fitting features can be cylindrical or width features. Fasteners are usually employed to enforce the full contact of the primary datum features.

## 8.2. The fit boundary and the theoretical gage

To assure fit, the design engineer must set up a fit boundary for the fit features and then identify the primary, secondary, and possibly tertiary datum surfaces to define a theoretical gage. The gage geometry must then be communicated to the manufacturing to define the necessary precision requirements. Figure 8-3 shows such a theoretical gage for the fit situation in Figure 8-2. In this example, the designer has chosen a 24 mm fit boundary. The theoretical or basic location of the feature relative to the locating datum is 60 mm.

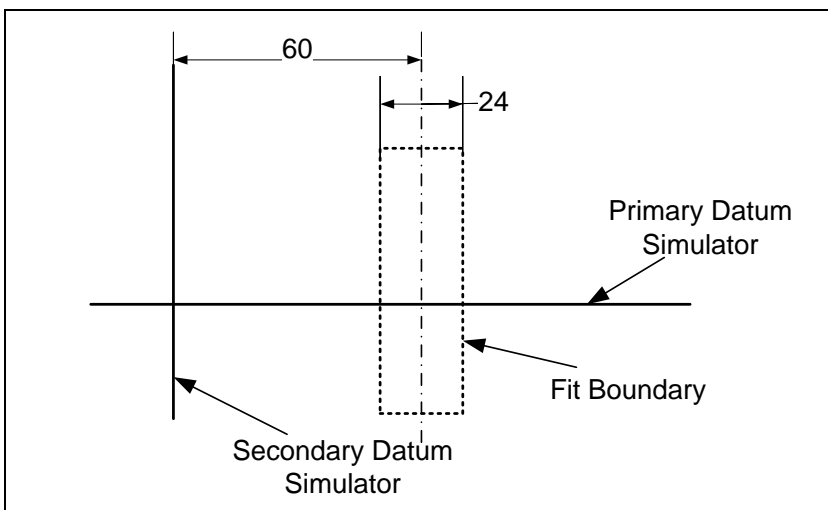
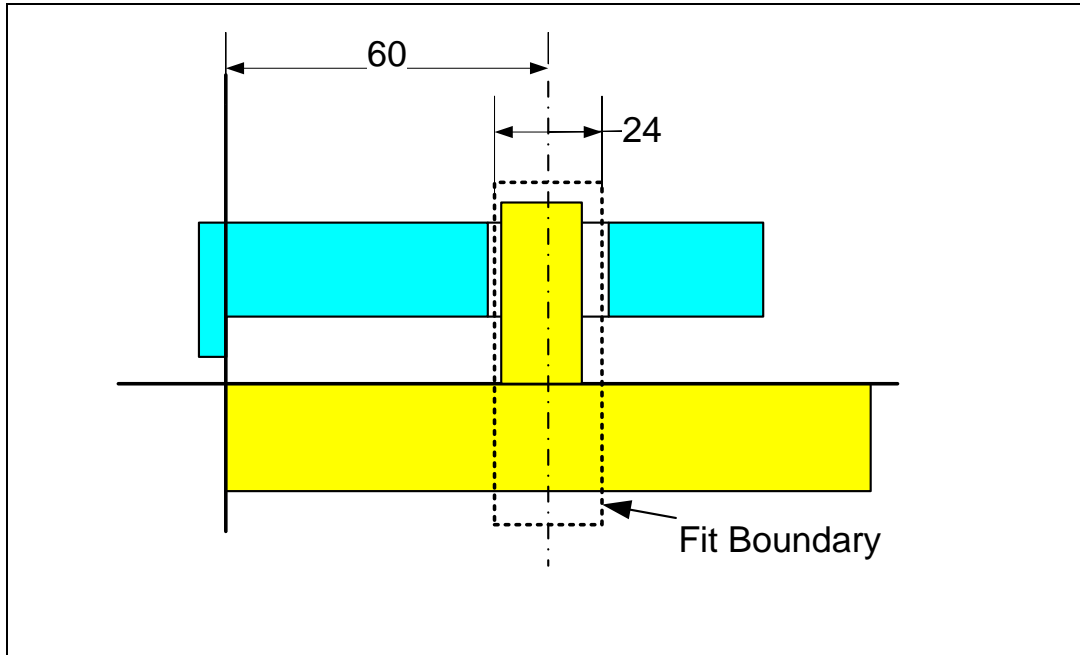


Figure 8-3. For location constrained fits the fit boundary is located relative to the datum planes

In order for the two fit features to fit together both parts must make full contact with the primary datum and also make a firm contact with the secondary datum. After the datum contacts are established, the hole feature must fit outside the fit boundary and the pin feature must fit inside the fit boundary. An example of such a fit is shown in Figure 8-4



**Figure 8-4. Fit is assured when the mating features clear the gage**

Although the pin feature clearly deviates from the theoretical location of 60 mm, it still fits inside the fit boundary because it is made close to its more slender LMC size. Just like orientation-constrained fits, the datum features must be flat enough to prevent the parts from rocking on the datum surfaces. In addition, the secondary datum must be specified to be sufficiently perpendicular to the primary datum surface to prevent fit problems. Designers must specify the datum features to be sufficiently flat and perpendicular to each other before using them in precision fit applications.

The GDT statement that conveys the theoretical gage geometry and method of gaging must disclose the following four sets of information:

1. A statement to describe the fit boundary size.
2. The identification of datum surfaces to be added to the fit boundary as datum simulators.
3. The theoretical location of the fit boundary with respect to the datum frame.
4. The order in which the datum features are to be aligned against the gage datum simulators during inspection (datum priority).

The first three items in the above list describe the geometry of the theoretical gage while the fourth item prescribes the order in which the part is to be constrained by the simulated datums of the gage. In addition to assuring fit the designer must control the fit play by controlling the LMC sizes of the fit features. In the case of the previous example in

Figure 8-2, the design engineer communicates the theoretical gage geometry using GDT statements shown in Figure 8-5 for the part with the pin feature.

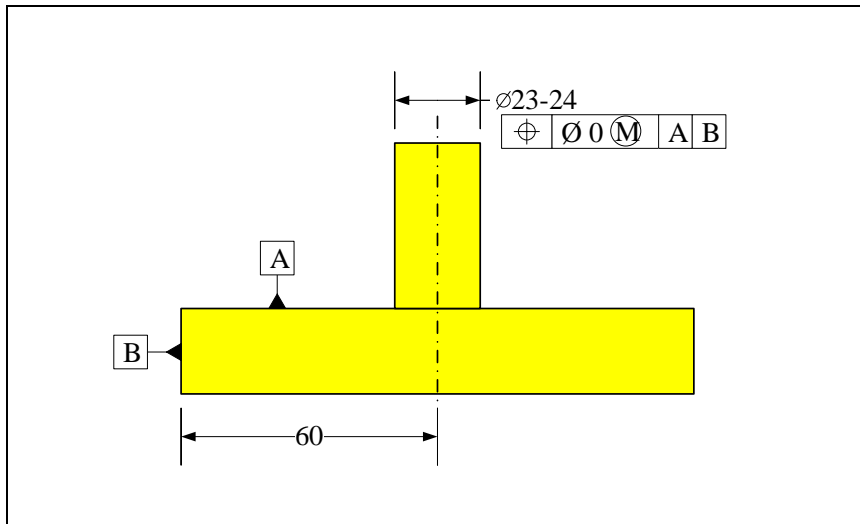


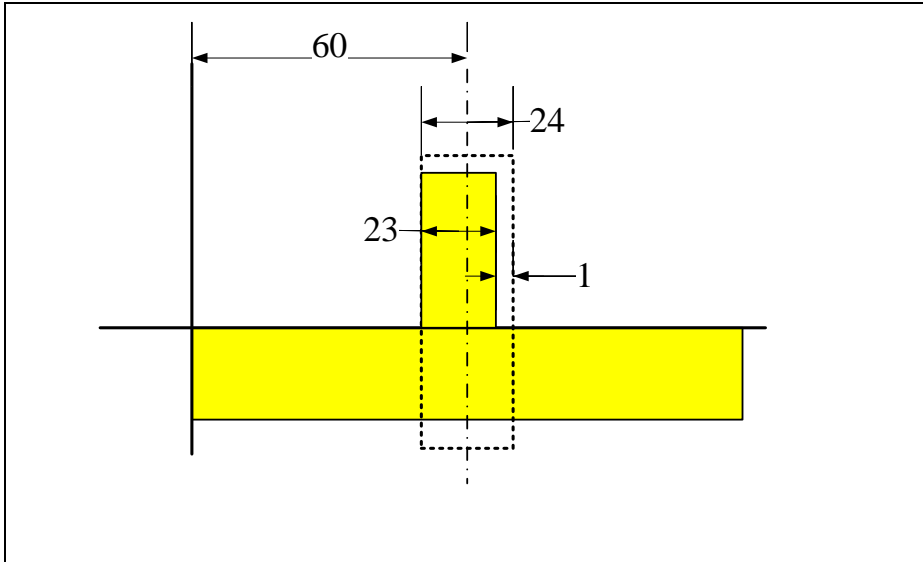
Figure 8-5. Description of 24 mm fit boundary using GDT position tolerance

In this position tolerance statement, the MMC size of the feature along with the tolerance value of zero at MMC define the size of the fit boundary to be 24 mm. The datums are identified and labeled as A and B and the tolerance statement specifies A as the primary datum and B as the secondary datum. Note that letter designations A and B do not imply anything regarding whether they are primary datum or secondary datum – it is the order in which they appear in the tolerance statement that makes that assignment. The theoretical location of the fit boundary with respect to the locating datum is given by a dimension of 60 mm.

The manufacturing interprets the fit boundary requirement as they appear explicitly in the tolerance statement as follows:

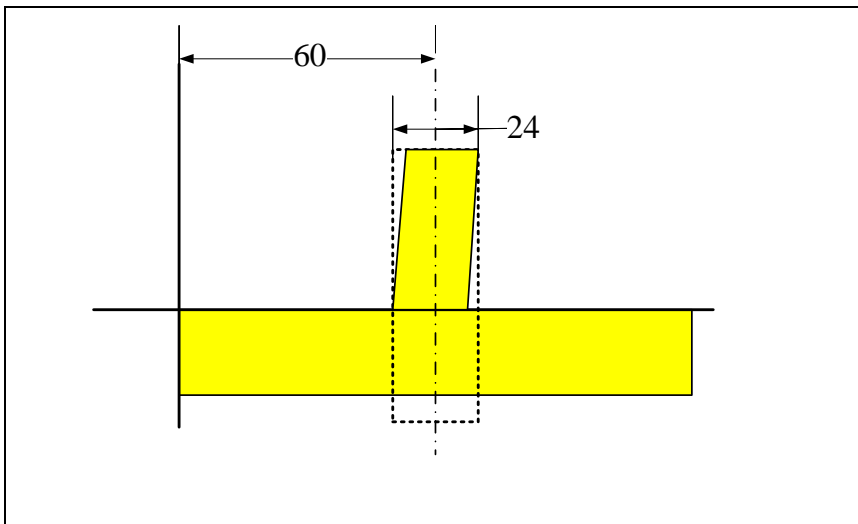
- *Make the pin such that its cross-sectional size will be between 23 and 24 mm.*
- *If the cross-section size is 24 mm (or at MMC), then the pin must be perfect in its form, orientation, and location. When the pin is made at its LMC size of 23 mm, then its combined form, orientation, and location deviation can be as much as 1 mm.*

One extreme shape of the pin that would be acceptable based on the tolerance description above is shown in Figure 8-6.



**Figure 8-6. The feature position may be off by 1 mm and still be acceptable**

The combination of the size and all geometric imperfections (form, orientation, location) must not lead to the pin crossing the fit boundary. Therefore when the position tolerance statement is applied, there is no need to control the orientation or form separately for fit purposes. This is because perpendicularity, for example, is automatically controlled to the extent that would lead to the feature fitting the gage. In Figure 8-6, the feature is shown to be perfectly straight and perfectly perpendicular to datum A. Any feature excessively tilted with respect to A or excessively bent would violate the fit boundary even if its derived axis is close to 60 mm with respect to datum B. An example is shown in Figure 8-7.



**Figure 8-7. A 23 mm feature may tilt 1 mm and still remain within the fit boundary**

The size of the fit boundary for external or pin features is the sum of the MMC size of the feature and the geometric tolerance at MMC, in this case, the position tolerance

$$FB_F = F_{\max} + T_F$$

And for a hole feature

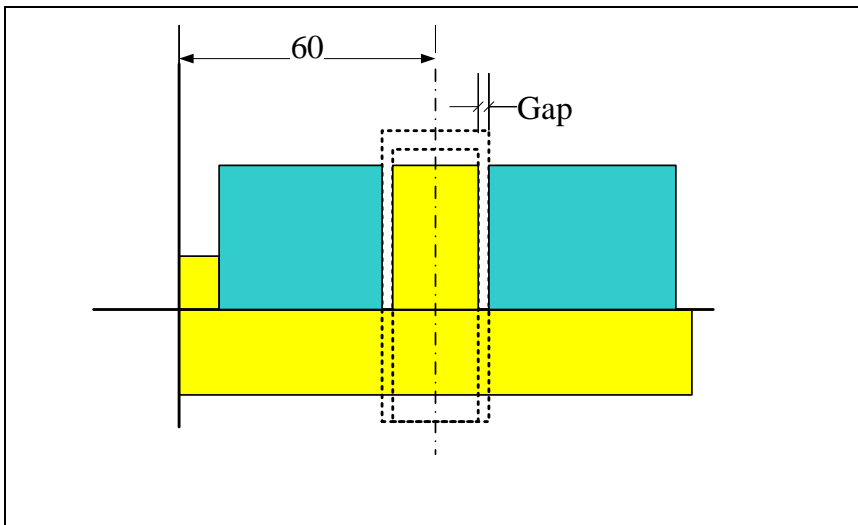
$$FB_H = H_{\min} - T_H$$

In this formulas  $T_H$  and  $T_F$  are the position tolerance values at MMC as indicated in the tolerance statement. Also,  $H_{\min}$  and  $F_{\max}$  are the MMC sizes of the hole feature and the pin feature.

In the direction where the two parts can have free play, the fit formulas developed for the orientation-constrained fits remain unchanged. The minimum play formula is

$$P_{\min} = (H_{\min} - F_{\max}) - (T_H - T_F)$$

In the direction where the features are fixed and there is no free play, there can be a minimum gap between the mating features. The minimum gap occurs between the two adjacent surfaces of the fit features as seen in Figure 8-8. In this figure, the fit boundaries are shown in dashed lines and are not equal in size.



**Figure 8-8. When fit boundary of pin is smaller than the fit boundary of the hole, there will be a guaranteed minimum gap in the fit.**

The minimum gap formula is

$$G_{\min} = \frac{1}{2}(H_{\min} - T_H - F_{\max} - T_F)$$

For an acceptable zero-clearance fit ( $G_{\min} = 0$ ) the fit formula remains as before

$$T_H + T_F \leq H_{\min} - F_{\max}$$

When zero position tolerance is used, the fit formula becomes

$$H_{0\min} - F_{0\max} \leq 0$$

Unlike unconstrained fits, there is rarely a need to have an assured minimum gap in a location-constrained fit. For all such fits,  $G_{\min}=0$  is often most desirable.

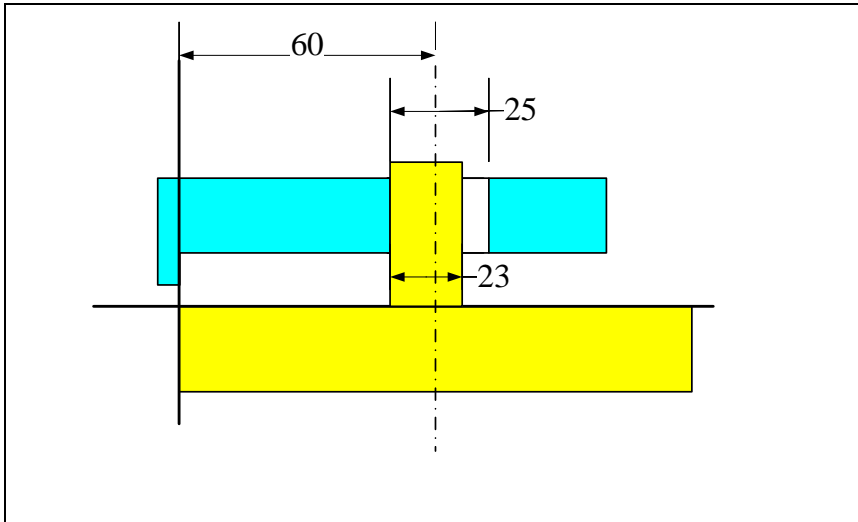
In the direction where the parts can slide, the maximum play formula based on LMC sizes is determined as

$$P_{\max} = H_{\max} - F_{\min}$$

In the direction where the two parts are fixed with respect to each other, the maximum gap occurs when both features are made at their LMC limit of size. When  $G_{\min}$  is set to zero, the formula for maximum gap is

$$G_{\max} = H_{\max} - F_{\min}$$

For a numerical example, suppose the hole feature has size limits of 24-25 mm and a position tolerance of zero at MMC and the pin feature size is 23-24 mm with a position tolerance of zero at MMC. The minimum gap is zero when both features are 24 mm in size, and the maximum gap can be 2 mm when both features are at LMC as shown in Figure 8-9. The shaft at LMC size of 23 mm has shifted to the left relative to its theoretical location by 0.5 mm while the hole at LMC size of 25 mm has shifted to the right by 0.5 mm.



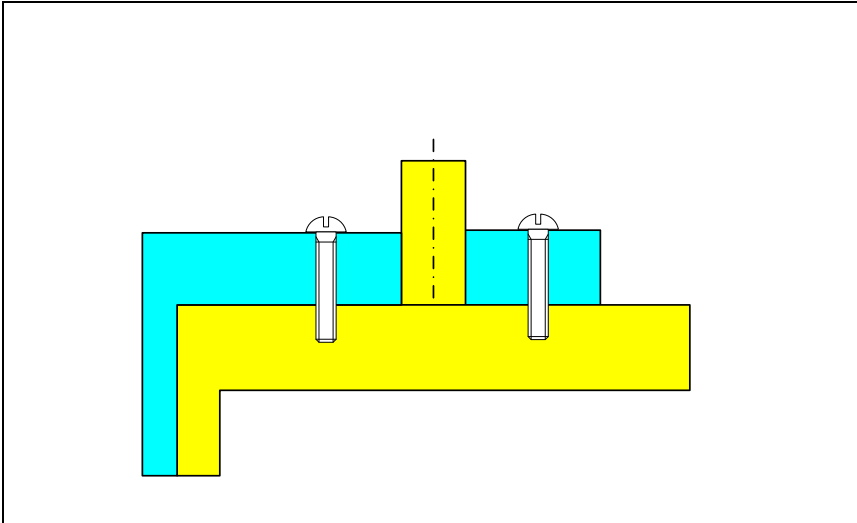
**Figure 8-9.** When the fit boundaries of pin and hole have the same size and the minimum gap is zero, the maximum gap is determined by the LMC sizes of the hole and the pin.

In the chapters on unconstrained fits and orientation-constrained fits it was argued that the use of the MMC boundary as the fit boundary was the best choice. That argument is also valid for the case of location-constrained fits and position tolerances when there is no objection to the feature being made at a wider range of sizes. Zero position tolerance at MMC combines the size and location tolerances into a larger size tolerance. The zero-position tolerance at MMC not only provides maximum flexibility in manufacturing but it also makes the tolerancing calculations easier.

### 8.3. Datum priority

A position tolerance statement prescribes a theoretical gage by defining a fit boundary that is oriented and located with respect to datums. While the theoretical gage has datum plane simulators that are perfectly flat and perfectly perpendicular to each other, the

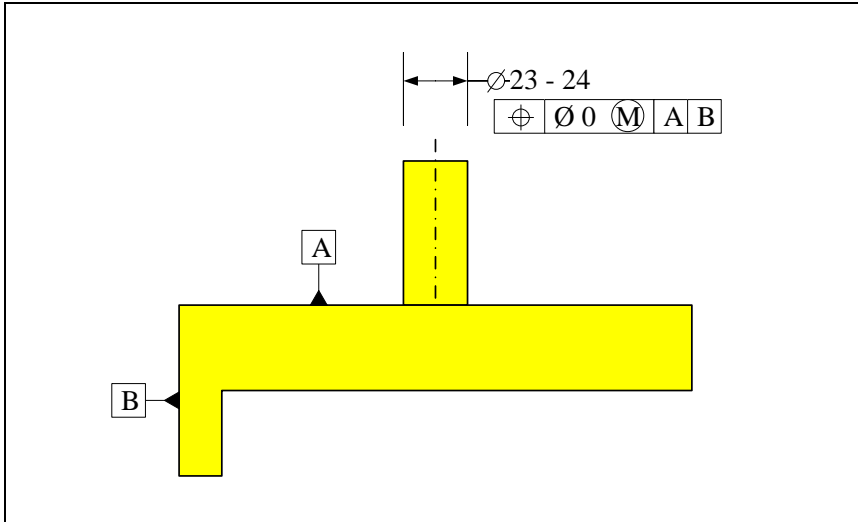
actual part that is to be checked against this gage would not have perfect datum surfaces. When there are multiple contact datum features, the order of constraining the part to the gage is important. The designer must carefully set up the order of datum contacts to mimic the way the part is to fit into the assembly. Consider the assembly shown in Figure 8-10.



**Figure 8-10. An example of a location-constrained fit**

In this fit, the design intent is to orient the two parts with respect to each other using the larger horizontal seating surfaces. There are fasteners that enforce this complete and firm contact in assembly. The designer must set up the problem such that the seating surfaces are selected as the primary orienting surfaces.

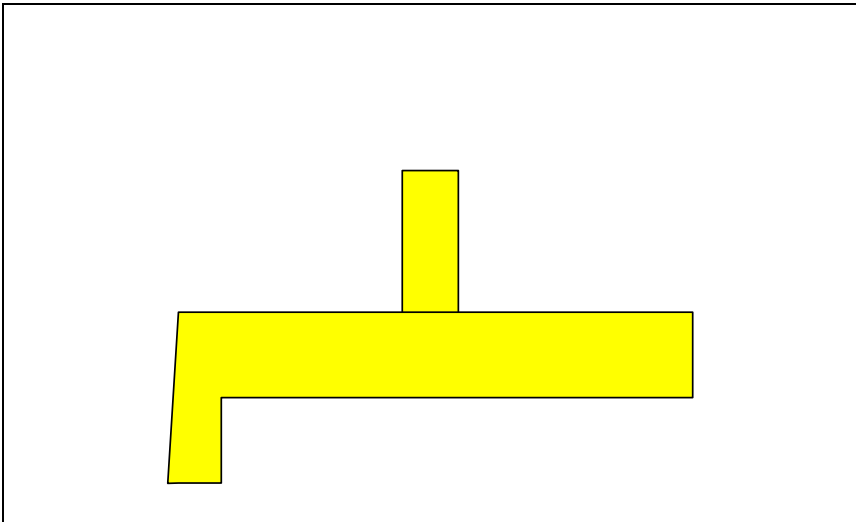
By specifying the datum priority, the design engineer can ensure that the part is made and gaged in a way that mimics its proper place in the actual assembly. If gaging and the actual application do not match, the parts may not fit properly. In this case by explicitly identifying the seating surfaces as the primary orienting datums, the designer instructs the inspection personnel how to gage the part and when to accept it. This can be done by calling the seating surface (labeled A) to be the primary orienting surface as indicated in Figure 8-11.



**Figure 8-11. Datum-A is designated as the primary datum and datum-B as the secondary datum**

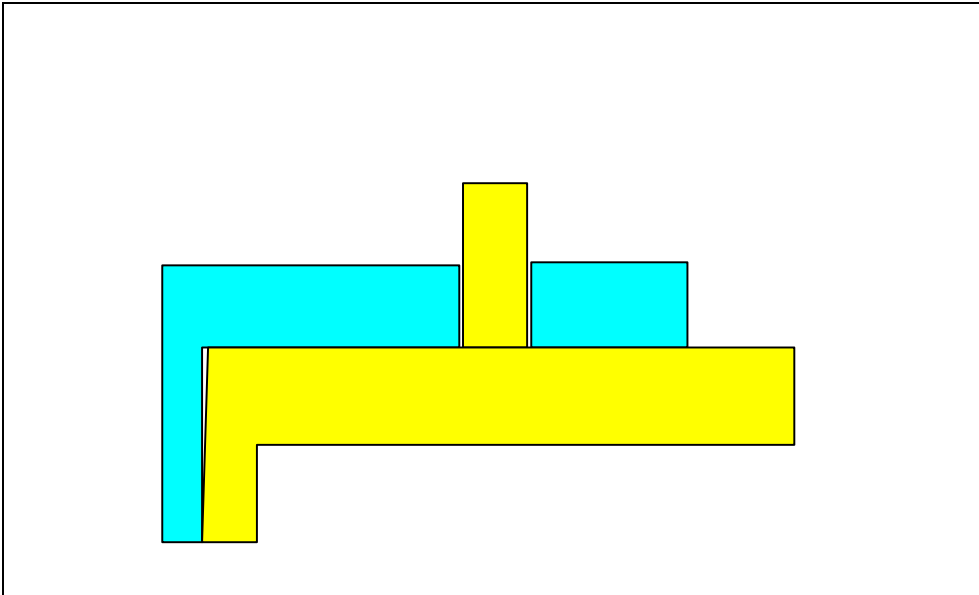
When the part with the pin feature is manufactured, the datum surfaces do not come out perfectly perpendicular. Therefore a pin that is made to be precisely perpendicular to the seating surface (surface A) would not be precisely parallel to the locating edge surface (surface B).

In the part shown in Figure 8-12 the pin is correctly made to be primarily perpendicular to the seating surface (surface A). The incorrect alternative, in this case, is to make the pin parallel to the side surface (Surface B).



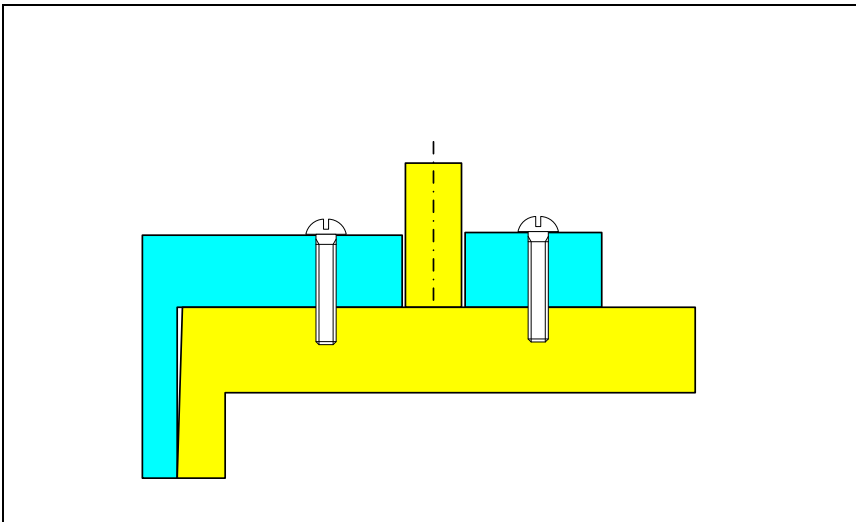
**Figure 8-12. The pin feature is well-made as its orientation (perpendicularity) is precise with respect to the primary datum feature**

This part passes the gage properly as shown in Figure 8-13. Note that the gaging correctly makes full contact with the seating or primary datum-A. If the gage incorrectly makes full contact with the B surface instead of A surface, the pin will not clear the gage.



**Figure 8-13. The part clears the gage and is acceptable.**

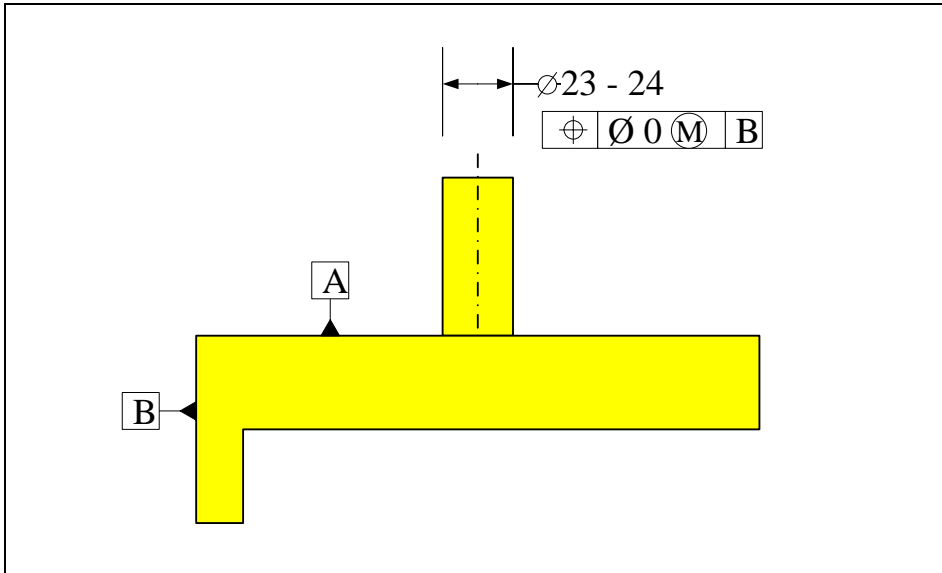
This part is acceptable and fits its mating part as intended when used in assembly as shown in Figure 8-14.



**Figure 8-14. The part fits the assembly just as it fits the gage it passed.**

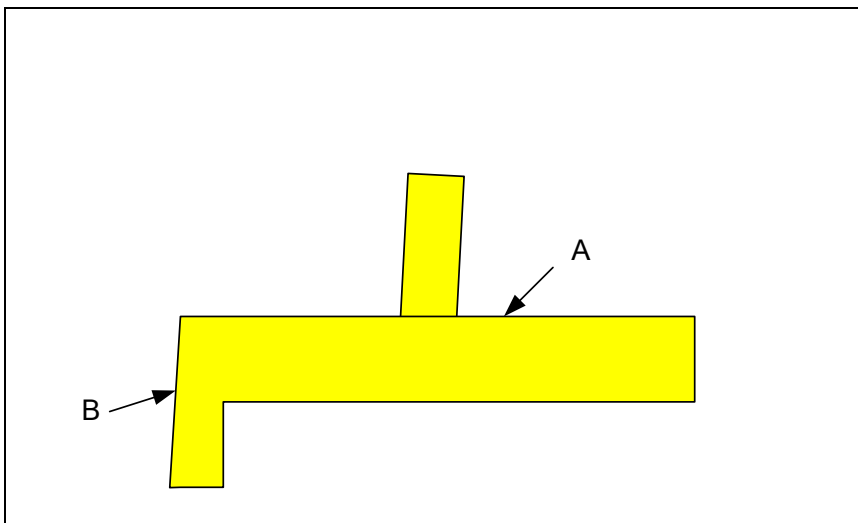
Fit problems occur when the design engineer overlooks the importance of the primary orienting datum and specifies surface B to be the primary datum that orients the two parts with respect to each other. It happens quite often because engineers intuitively do not see the importance of the orienting surface and only consider the pin's distance to the side

surface as the only relevant geometric criterion. This incorrect specification scheme is shown Figure 8-15.



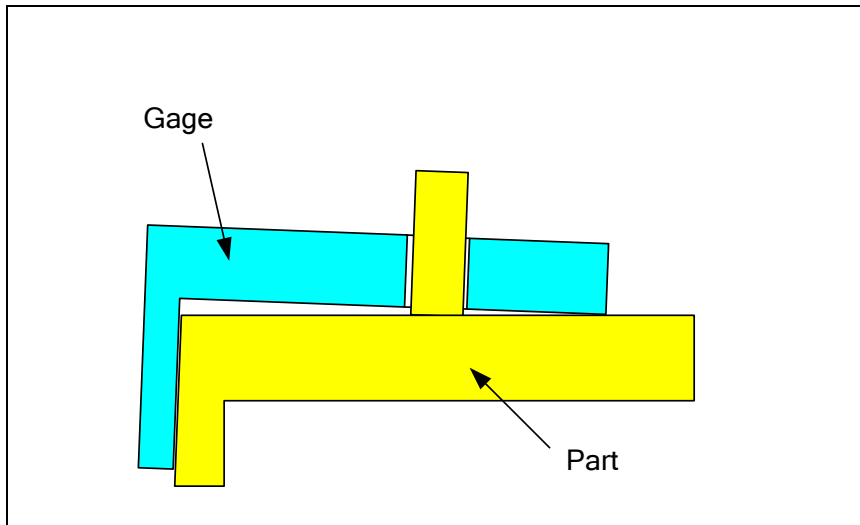
**Figure 8-15. Incorrect specification of the primary orienting datum given the manner of assembly**

This specification tells the manufacturing that the orientation relationship between the pin and surface A is less important than B. When the manufacturing sees that only the edge datum (surface B) is called out in the position statement they try to make the pin feature more parallel to the edge datum surface and at a distance of 60 mm from that edge datum. Figure 8-16 shows an exaggerated shape for the purpose of illustration.



**Figure 8-16. The pin feature is well-made as its orientation (parallelness) is precise with respect to the primary datum feature (B in this case)**

The inspector also attempts to gage this according to the specification which calls for full contact of gage with surface B. In this manner the gage fits the part as shown in Figure 8-17 and subsequently the part is accepted. The gage simply verifies that the pin is precisely parallel and at a precise distance from surface B exactly as the design engineer specified it.



**Figure 8-17. When checking the part, the side surface (datum-B) is aligned with the datum feature for full contact**

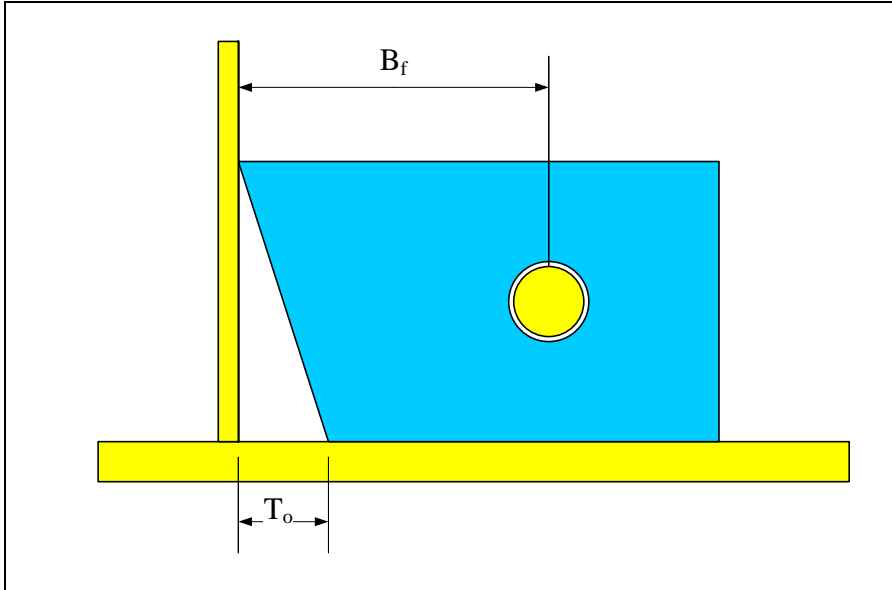
This figure also shows what is going to happen during the actual assembly because the gage simply acts as a mating part. This manner of assembly is clearly not what the designer intended. It only occurred because the designer overlooked the fact that datum-A should be the primary orienting surface during assembly, not datum-B. Adding datum-A as the secondary datum does not change anything. In fact, adding datum-A as a secondary datum can be confusing to manufacturing because it neither orients nor locates the subject feature.

#### **8.4. Datum frame precision**

As in the case of orientation-constrained fits, the primary orienting datum feature should be flat enough not to rock. The secondary datum feature must also be sufficiently flat to prevent rocking. The secondary datum, however, has restricted freedom and its flatness need not be controlled with as much precision as the primary datum. In addition, the secondary datum feature's perpendicularity with respect to the primary datum must be controlled with high accuracy. The tertiary datum's orientation with respect to the primary and the secondary datum features must also be controlled with sufficient accuracy. When the perpendicularity tolerance is specified to be small enough to prevent rocking, there is usually no need for additional flatness tolerance.

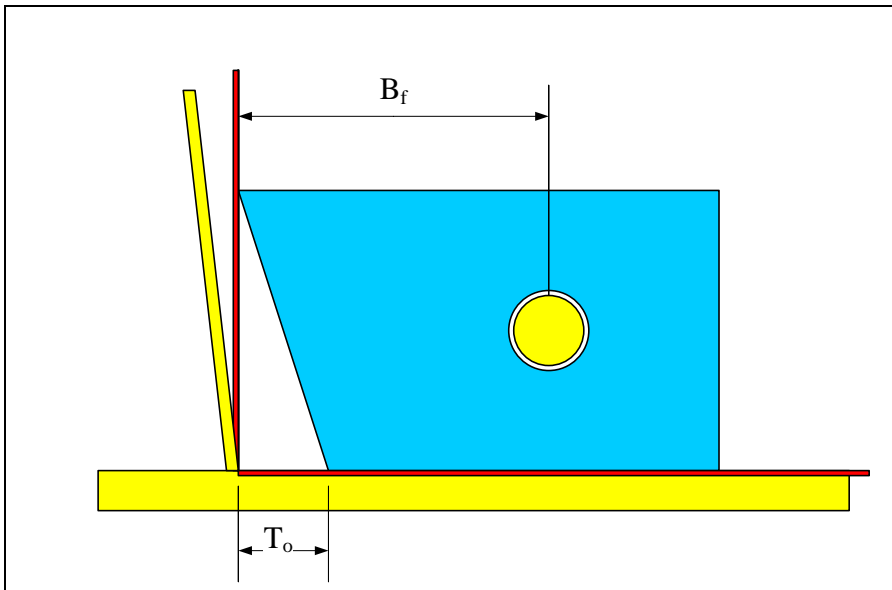
Consider a typical case where a secondary datum locates two mating parts with respect to each other. There would be adverse locating consequences when the secondary datum is

not sufficiently perpendicular to the primary datum. This is shown in Figure 8-18 where the part with the hole has a poorly perpendicular secondary datum while the part with the pin has a perfectly square datum frame. The orientation tolerance, in this case perpendicularity, is  $T_o$ .



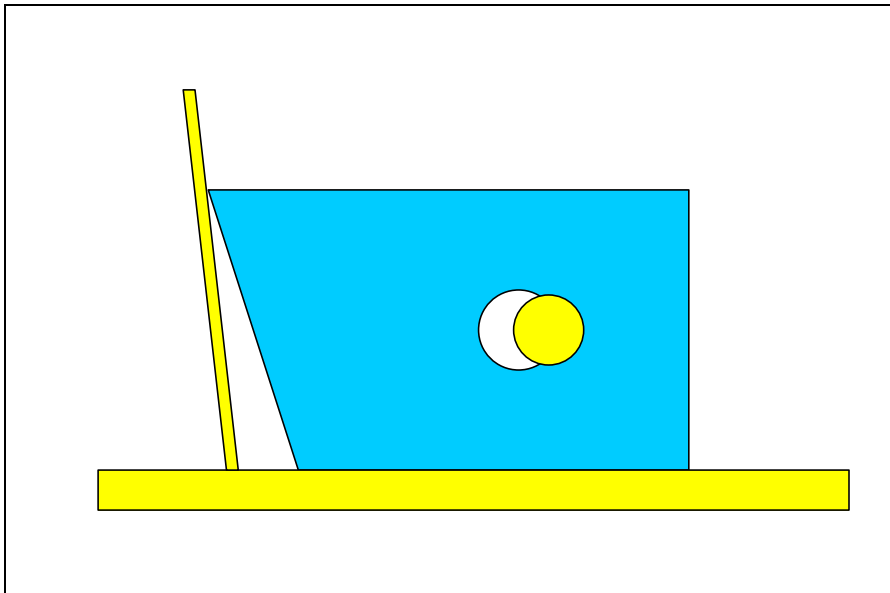
**Figure 8-18.** Even when the secondary locating datum is not square to the primary datum the part fits the gage and is deemed acceptable.

It appears in the above figure that lack of perpendicularity has no effect on fit as the part passes the gage. The problem reveals itself only when both parts have non-perpendicular datum frames. Consider the situation shown in Figure 8-19.



**Figure 8-19.** Both parts fit the gage individually by they do not fit together

The red lines represent the theoretical gage datum simulator for both parts. Both the hole and pin features align properly and pass the inspection when tried separately against the gage. Figure 8-20 shows what would happen when the two parts are put together. In this case, the blue part slides past the theoretical datum plane and the locations of the fit features do not match. In this case failure to fit is solely caused by inadequate control of the datum frame geometry. Adequate control of datum frame geometry is also important in multi-part fits (Chapter-10).



**Figure 8-20. Passing the gage test may not assure fit when the precision of the datum frame is poorly controlled**

The design engineer can set up the fit boundary sizes to account for the effect of the secondary datum's perpendicularity imperfection. The effect of secondary datum can be incorporated into the fit formula by including a datum allowance term. The new fit formula would be

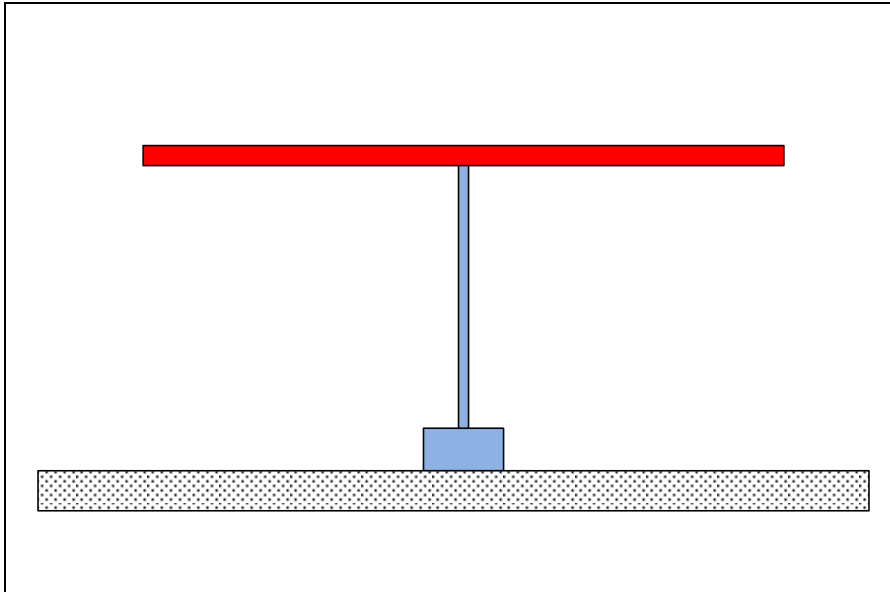
$$T_H + T_F + T_{o,2} \leq H_{\min} - F_{\max}$$

$T_{o,2}$  is the secondary datum's perpendicularity imperfection allowance.  $T_{o,2}$  is the smaller of the perpendicularity tolerance values of the two datum frames of the two mating parts. The effect of the tertiary datum perpendicularity can be similarly added to the fit formula. While the effect of datum feature imperfections can be explicitly accounted for in fit calculations, the general practice is to ignore their contributions in the fit formula and fit analysis, provided the datum frame accuracy is adequately controlled.

## **8.5. Imperfect geometry relationships are not intuitive**

In other engineering analysis or simulation applications we do not need to worry about slight geometric imperfections because they are often unimportant and make little difference in the analysis results. This is not the case for fit and function applications. In that respect, some geometric relationships that appear to be equivalent may not be so for imperfect parts. The lack of intuitive feel when dealing with imperfect geometry has

created a lot of confusion for many students and engineers. For example, when surface A is parallel to surface B, then obviously surface B is also parallel to surface A. We may ask what difference would it make to say A must be parallel to B to within 5 mm versus B is to be parallel to A to within 5 mm. These two specifications, however, can result in very different acceptable geometries. For example, the designer of a table wants to have the tabletop to be parallel to the table base to within 5 mm. Figure 8-21 shows the table.



**Figure 8-21. A simple table**

Believing that it makes no difference, the designer specifies the base to be parallel to the tabletop to within 5 mm instead. Perhaps the tabletop had already a datum label and it was easier to make the base parallel to it. This designer may be quite surprised to see the possible results of such a specification.

The reason is that a 5 mm tolerance zone containing the long tabletop results in a smaller angle between the tabletop and the base as compared to the same tolerance zone containing the shorter base. For example if the tabletop is 1500 mm long, a 5 mm tolerance zone applied to it results in a maximum angle relative to the base of

$$\theta = \tan\left(\frac{5}{1500}\right) = 0.033 \text{ Rad} \quad \theta \cong 0.2 \text{ deg}$$

If the base is 500 mm long, the same 5 mm tolerance zone applied to it results in a maximum angle relative to the tabletop of

$$\theta = \tan\left(\frac{5}{500}\right) = 0.01 \text{ Rad} \quad \theta \cong 0.5 \text{ deg}$$

While the two specifications appeared to be equivalent, the results are quite different. In this case the tilt resulting from a 5 mm parallelness tolerance zone can be different by a factor of 2.5 when the subject and datum features reverse roles.

## 8.6. Fit of feature patterns

A feature pattern is a collection of identical features usually having identical functions. The most common feature pattern is a pattern of fastener holes fitting a pattern of pins. Figure 8-22 shows a pattern of 4 holes fitting a pattern of four pins.

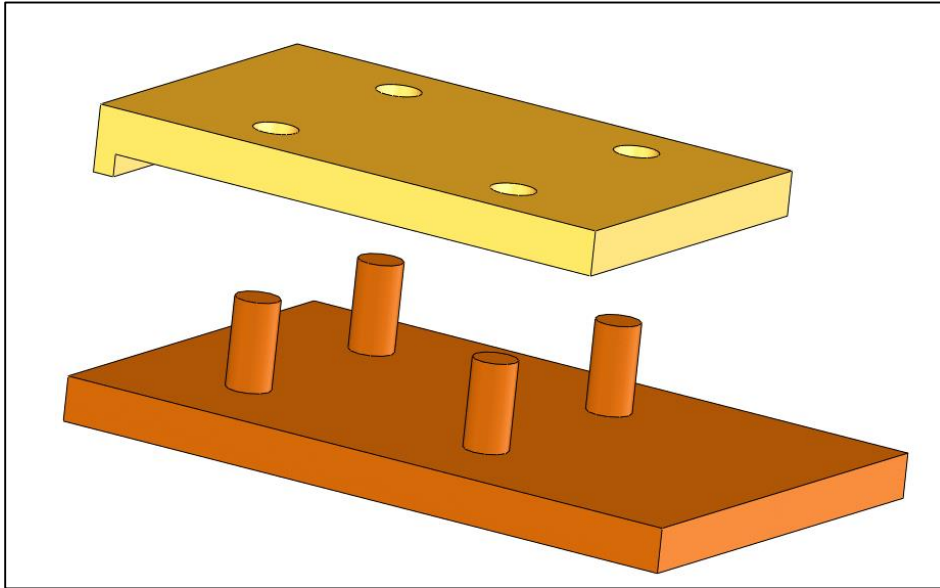
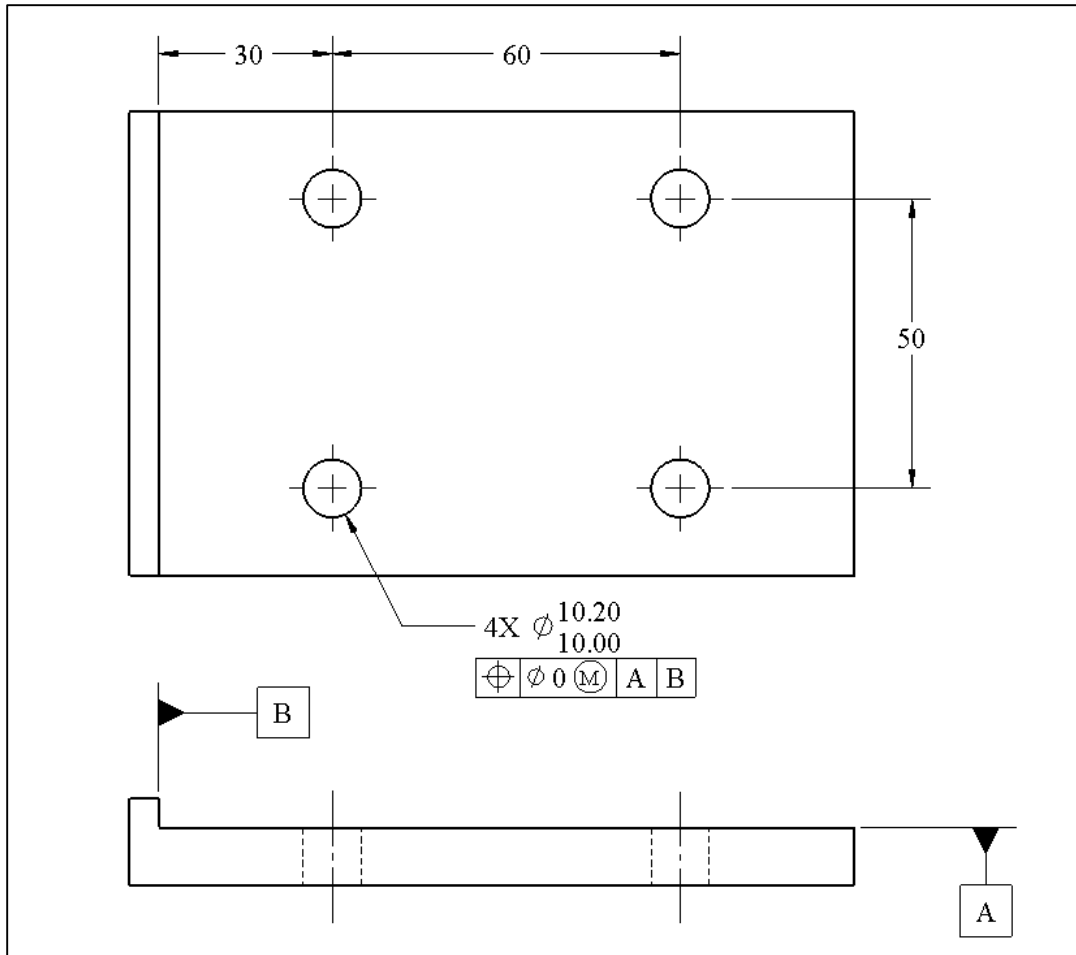


Figure 8-22. The fit of a pattern of holes and pins

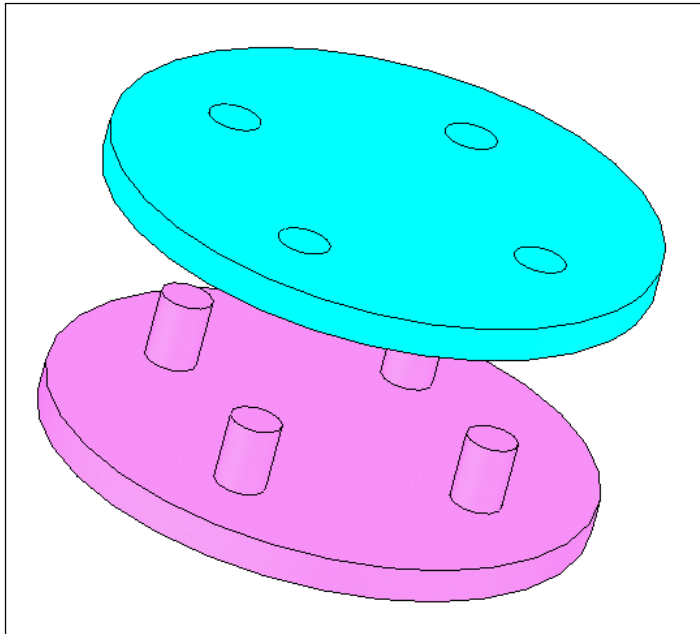
To assure this fit, the designer needs to increase the number of fit boundaries to match the number of the fit features and provide the basic locating dimensions between them. This can be easily done by adding 4X to the tolerance statement as shown in Figure 8-23 for the part with holes. The precision of the datum system must also be specified but is not shown in this figure.



**Figure 8-23.** The 4X designates a pattern and the position tolerance defines a gage made of a pattern of four fit boundaries with theoretical distances within the pattern and with respect to datum planes

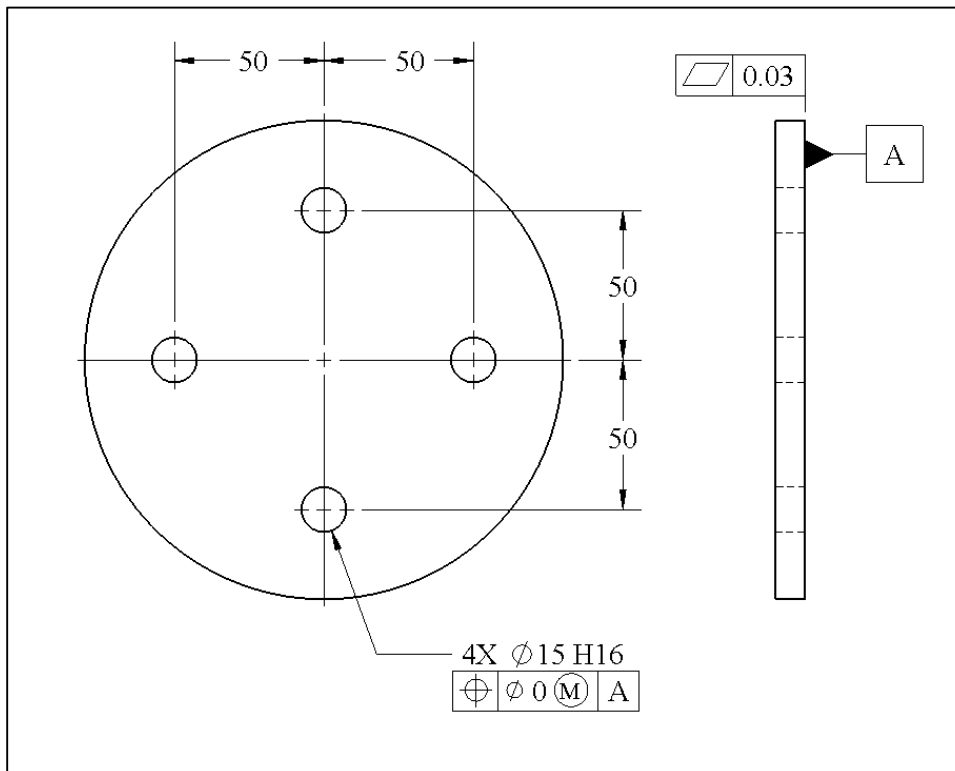
When the mating pins have a size of 9.8-10.0 mm with a zero position tolerance at MMC, the maximum play in the fit can be 0.4 mm. Note that the pattern location with respect to the top or bottom side edges is not critical for this assembly and for that reason the pattern is not located with respect to those edges. Unspecified non-precision geometric requirements, however, are controlled by default tolerances.

In many fit problems involving patterns, there is only one primary orienting datum and no contacting side datums such as the assembly in Figure 8-24.



**Figure 8-24. A pair of fitting parts with only one orienting datum**

In this example only one orienting datum is needed. Figure 8-25 shows how the part with holes can be tolerated for fit.

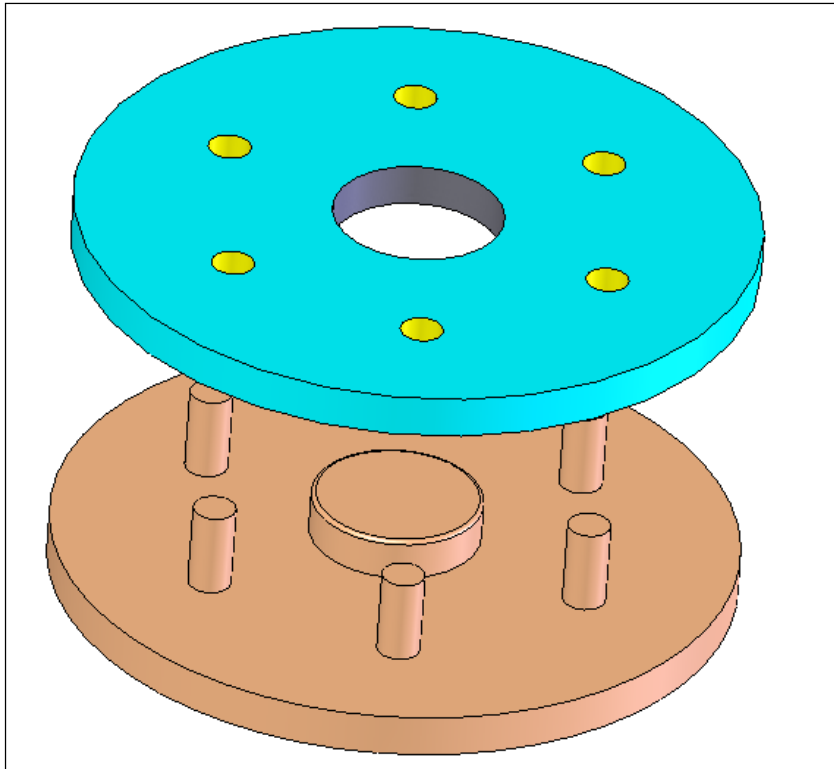


**Figure 8-25. Position tolerance necessary for fit**

The position tolerance defines a gage made up of four 15 mm fit boundaries with 50 mm distances within the pattern. The pins are perpendicular to datum surface A.

### 8.7. Simultaneous fit of different features

The majority of fit problems involve more than a single feature or a single feature pattern. Different features with different fit requirements are designed to achieve the required precision alignment between two parts. An example is shown in Figure 8-26.



**Figure 8-26. An example of a simultaneous fit involving a pattern and another fit**

In this example, the two parts are centered with respect to each other with precision using a relatively tight fit between a locating hole and a locating boss. The studs and bolts are then used to immobilize the assembly in place. To assure fit, fit boundaries are first chosen for all fitting features. For example a fit boundary of 40 mm is chosen for the center feature fit and 10 mm fit boundaries are chosen for the stud fit. The 10 mm fit boundaries of stud features are on a 50 mm radius circle and they are equally spaced.

A relatively snug fit can be obtained if the center hole is a 40H10 and the center boss is 40h9 both with a zero geometric tolerance (perpendicularity) at MMC. Note that using zero geometric tolerances makes the size tolerances to be the combined size and perpendicularity tolerances. These tolerances can be easily held by processes having the accuracy of finish milling operations. The maximum possible play in the hole and boss fit is

$$P_{\max} = t_H + t_F = 0.10 + 0.062 = 0.162 \text{ mm}$$

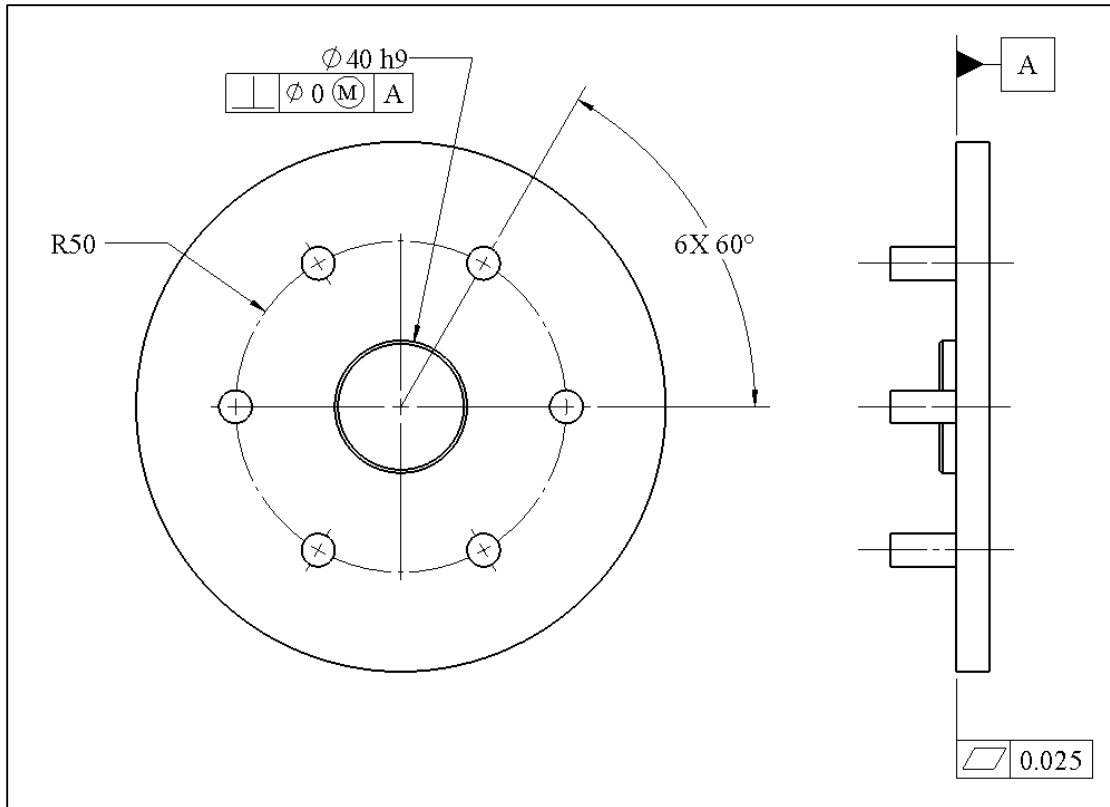
Since the fastener holes and studs are not precision, we can choose a 10H16/h16 specifications for their fits.

The design engineer must communicate the size limits and geometric tolerances necessary to define the fit boundary sizes and the datum simulators to manufacturing. From the designer's perspective, the requirements are very simple. For the part with studs the designer wants to communicate the tolerance information as follows:

- *Make the part such that it would fit a gage made of one hole of size 40 mm and six holes of size 10mm uniformly spaced around it at a distance of 50mm from the axis of the center hole. The part must make primary orienting contact on the seating surface of the gage. Furthermore, the LMC size of the boss is to be 39.938 mm and the LMC sizes of the studs are to be 9.1 mm.*

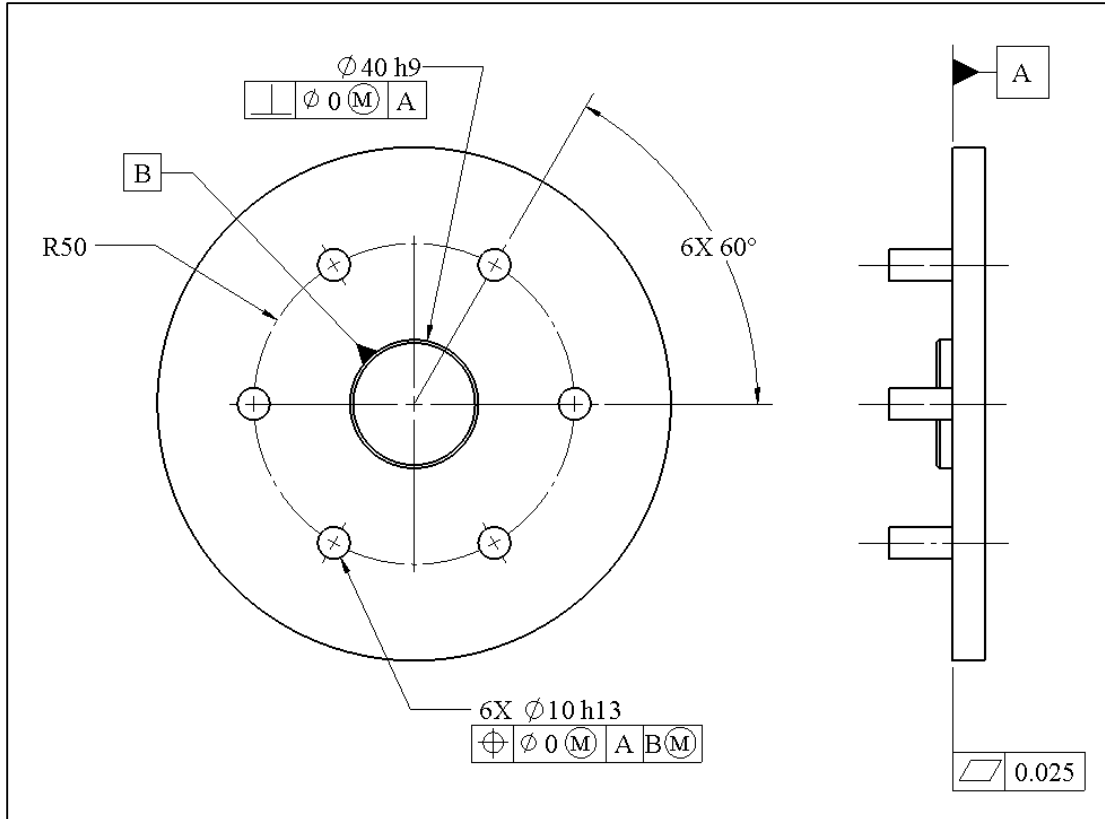
The most convenient way of communicating the theoretical gage information is by declaring the sizes of the two fit boundaries and the datum simulator associated with the theoretical gage.

In the GDT standard, this gage is specified in two statements, one defines the fit boundary of the center boss feature, and the other defines the fit boundary of the studs relative to the boss. The tolerancing of the part for the first statement (defining the 40 mm fit boundary) is shown in Figure 8-27 for the part with the boss and studs. This feature will be labeled as datum-B when defining the rest of the gage.



**Figure 8-27. The perpendicularity statement defines the fit boundary of the center feature**

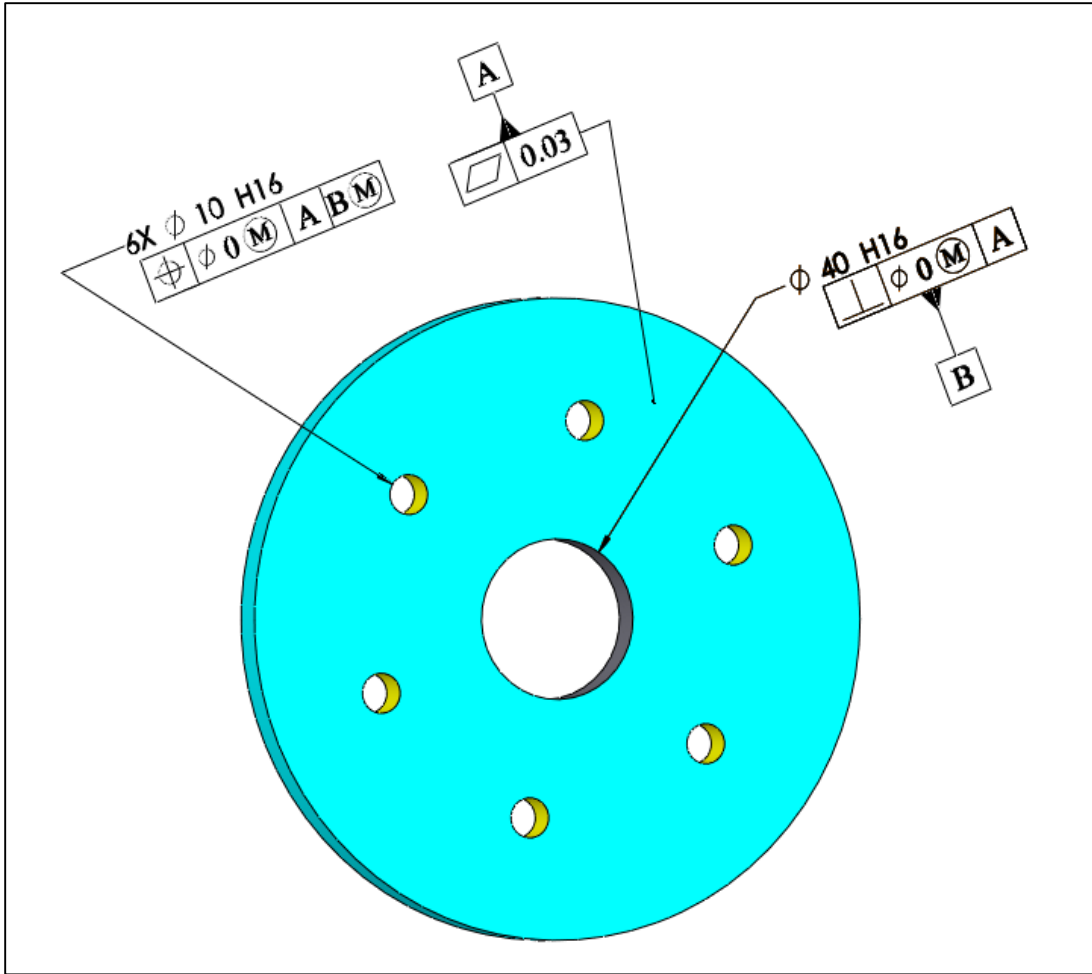
This statement only applies to the center boss and defines its fit boundary and LMC size as if the pin features did not exist. Next, we have to define the fit boundary for the pins placed around the 40 mm boundary using a second tolerance statement. This is accomplished by a position tolerance statement. Figure 8-28 shows the tolerance statement for defining the complete gage.



**Figure 8-28.** The two statements together define a gage with proper fit boundaries for both fitting features arranged theoretically with respect to each other

The position statement defines 10 mm fit boundaries and locates them in a circular pattern as indicated by the basic location dimensions. The fit boundary pattern for the studs is also specified to be oriented normal to datum-A. Finally, the pattern must be specified to combine with the fit boundary of the center boss. This is done by identifying the boss as datum-B. In the position tolerance statement this datum-B is referenced with a  $\textcircled{M}$  symbol following the datum letter. When  $\textcircled{M}$  symbol is used with a datum label, the datum is said to be at maximum material boundary (MMB).

Figure 8-29 shows the final specifications for the part with center holes and fastener holes shown on a 3D part model. The position tolerance statement applied to the pattern of holes can be interpreted as having a fit boundary geometry (pattern of pins of size 10 mm), a datum plane (datum A), and a MMB datum as a constraint geometry (a boss of size 40 mm).

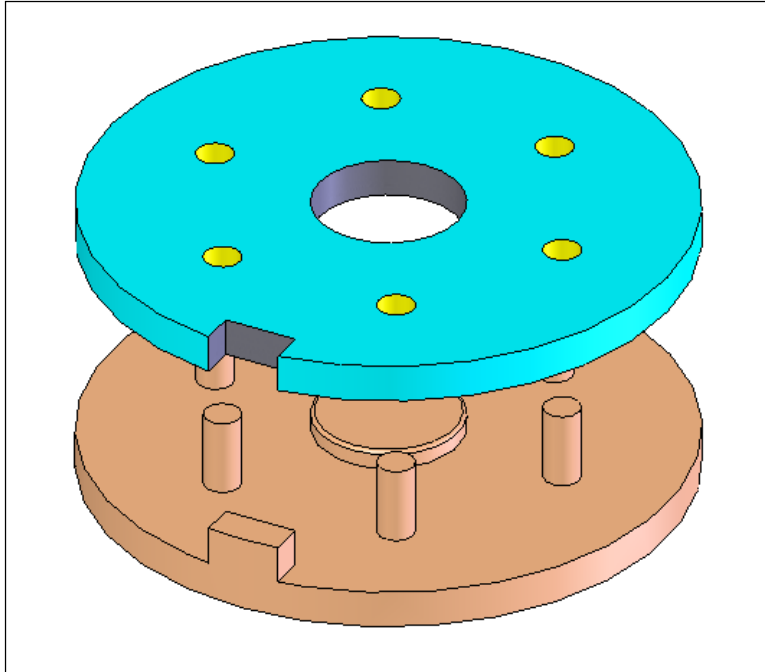


**Figure 8-29.** The center hole specification defines the fit boundary of center hole. The pattern of hole specification defines a pattern of fit boundaries around the center hole fit boundary.

Just like in an actual fit practice, the gage allows any slack in the center feature fit to compensate for the shift of the hole pattern.

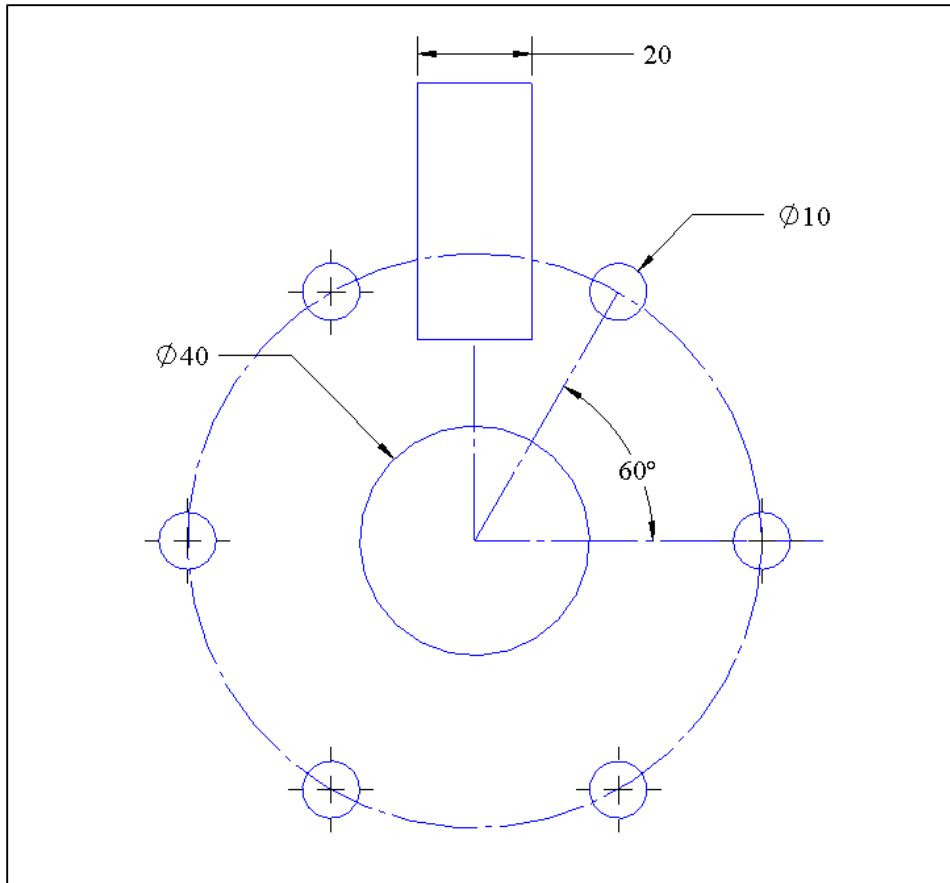
### **8.8. Additional alignment fit features**

In the previous example the two parts were centered using the precision fit of the center boss and the center hole. If a precise rotational alignment is also required, two new fit features can be introduced, an alignment slot on one part and an alignment rail on the mating part. Alternatively, an additional precision pin/hole feature can be added to the design. Figure 8-30 shows a rail/slot design.



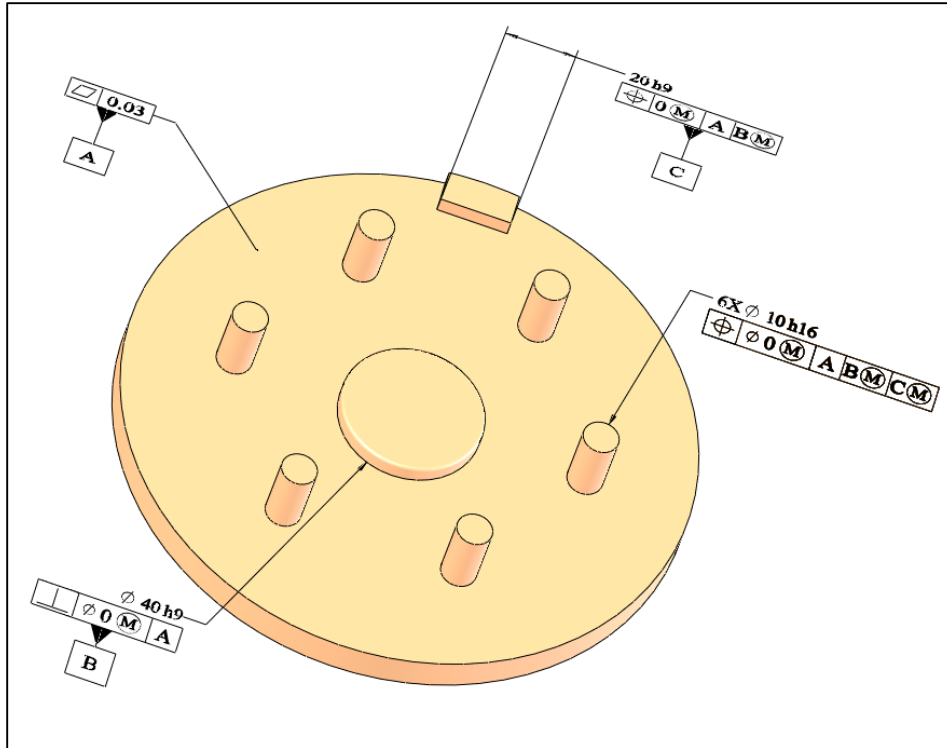
**Figure 8-30. The slot and rail fit precisely aligns the two parts in the rotational direction**

We can plan to have a 20H10/h9 fit in the rail and slot feature similar to the precision of boss fit. If the rotational alignment is more critical, we can select a more precision H/h fit. The theoretical gage necessary for this fit is made up of a pattern of 10 mm holes, a datum plane, a cylindrical fit boundary of size 40 mm, and a width fit boundary of size 20 mm that serves as another datum. This theoretical gage (top view) is shown in Figure 8-31. The gage geometry is the same for both parts as the fit boundaries of mating features are the same.



**Figure 8-31. The theoretical gage includes a datum plane and three fit boundaries of which one is a pattern**

The translation of this new conceptual gage geometry into the part tolerancing follows the same procedure as the previous example. The specifications describing the conceptual gage are shown in Figure 8-32 for the part with studs.



**Figure 8-32. Tolerance statements necessary to define the conceptual gage for the simultaneous fit of all fit features**

The GDT translation procedure starts with the labeling of the primary orienting datum. The definition of the fit boundary associated with the 40 mm cylindrical boss feature requires a perpendicularity statement. The boss feature would be labeled as datum-B and it would be used as a MMB datum. The fit boundary associated with the 20 mm rail feature is defined through a position tolerance statement. Position tolerance is the appropriate statement because the center plane of the rail feature must pass through the axis of the boss. In this case, the basic dimension that locates the center plane of the rail with respect to the axis of the boss is zero. This rail feature is labeled as datum-C and will be specified as an MMB datum.

In the above example the choice of which MMB-datum to specify first does not make a difference in the description of the final theoretical gage or in the gaging practice. We could have selected the width feature as the secondary datum and the center cylindrical feature as the tertiary datum. The preference is to select the datum priority based on either the precision of fit or the order in which the features are likely to be assembled.

### **8.9. Situations where the use of $\textcircled{M}$ is not possible or recommended**

As mentioned previously in orientation-constrained fits, when the size of a feature needs to be controlled with precision for any reason, its size tolerance must be specified as

needed. The size tolerance must not be expanded to include the position tolerance. A common case is when a hole feature accepts a press-fit insert. The use of MMC modified position tolerance may also be inappropriate in some multipart assemblies. This subject will be covered in detail in Chapter-10.

### 8.10. Defining a fit boundary without the $\textcircled{M}$ modifier

Fit boundaries based on position tolerances can also be defined RFS. For two part fits the use of  $\textcircled{M}$  modified position tolerance is preferred. When precision size control is necessary for other reasons, the RFS statement must be used.

We can compare the fit performance of using an  $\textcircled{M}$  modifier versus the RFS specification in two-part fits in an example. Figure 8-33 shows the simple two-part fit presented in the beginning of this chapter.

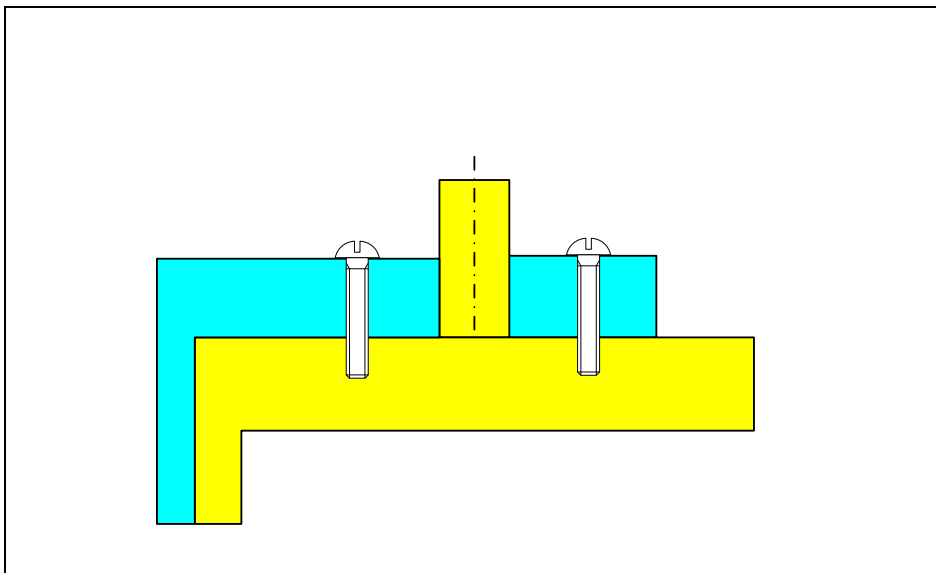
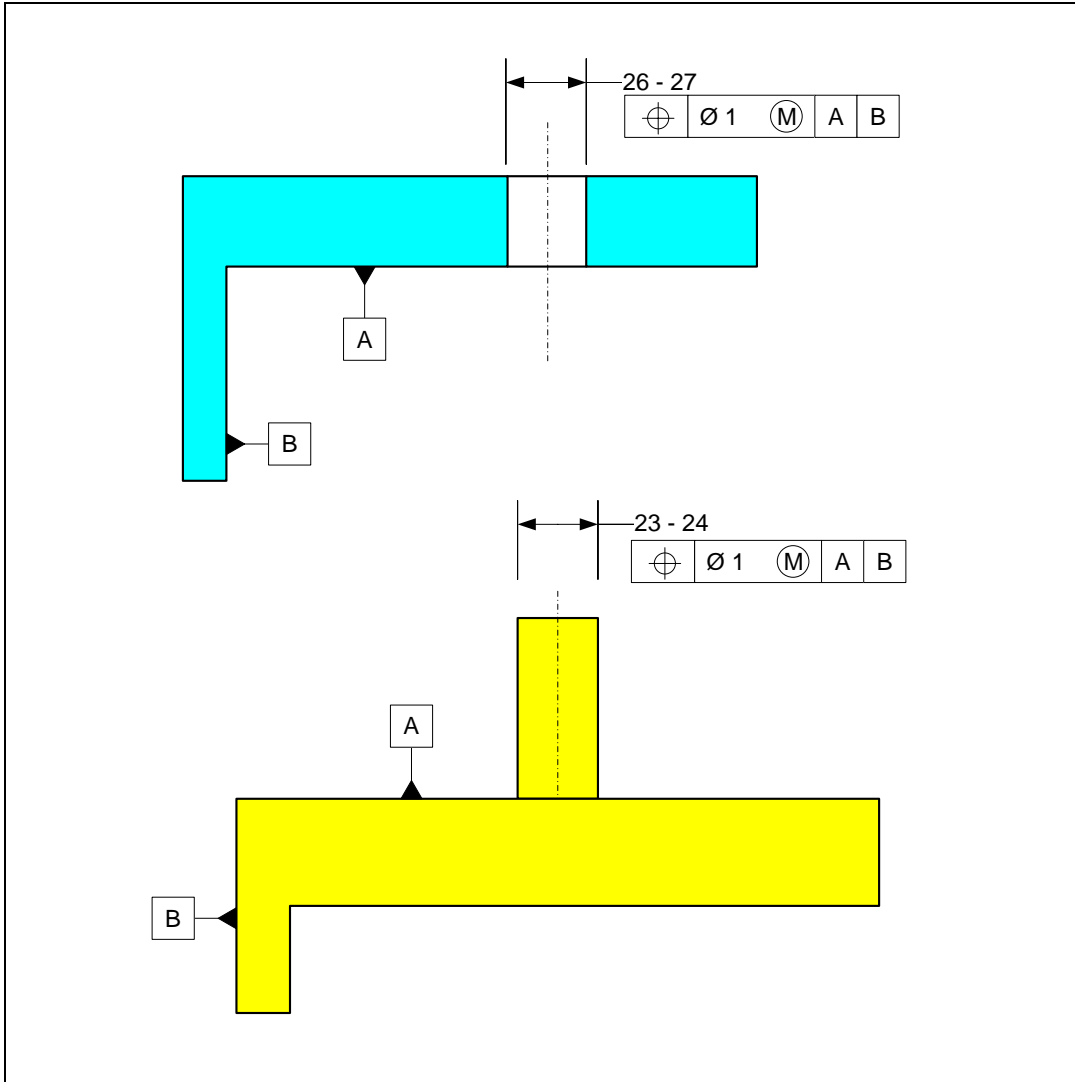


Figure 8-33. An example of a location-constrained fit

*Using  $\textcircled{M}$  modifier:* The tolerancing of the two mating parts shown in Figure 8-34 is a good method of tolerancing and assures a fit with a minimum gap of zero.



**Figure 8-34. Parts set up for location-constrained fit using M modifier**

The fit boundary size for both features is 25 mm. The fit is assured with a minimum gap of zero while the maximum gap of 4 mm occurs in the direction where both features are location constrained. To check the maximum possible gap we can model the two parts at their LMC limit of size with position deviations allowed at LMC. In this case a 2D sketch model using a CAD system is easy and sufficient to see the geometric relationships. Figure 8-35 shows the sketch model of the two parts. The theoretical positions are 80 mm. The feature sizes are set to 27 mm for the hole and 23 mm for the pin. The pin has its maximum radial deviation of 1 mm to the right while the hole has a maximum deviation of 1 mm to the left. The calculated maximum gap between the features is 4 mm.

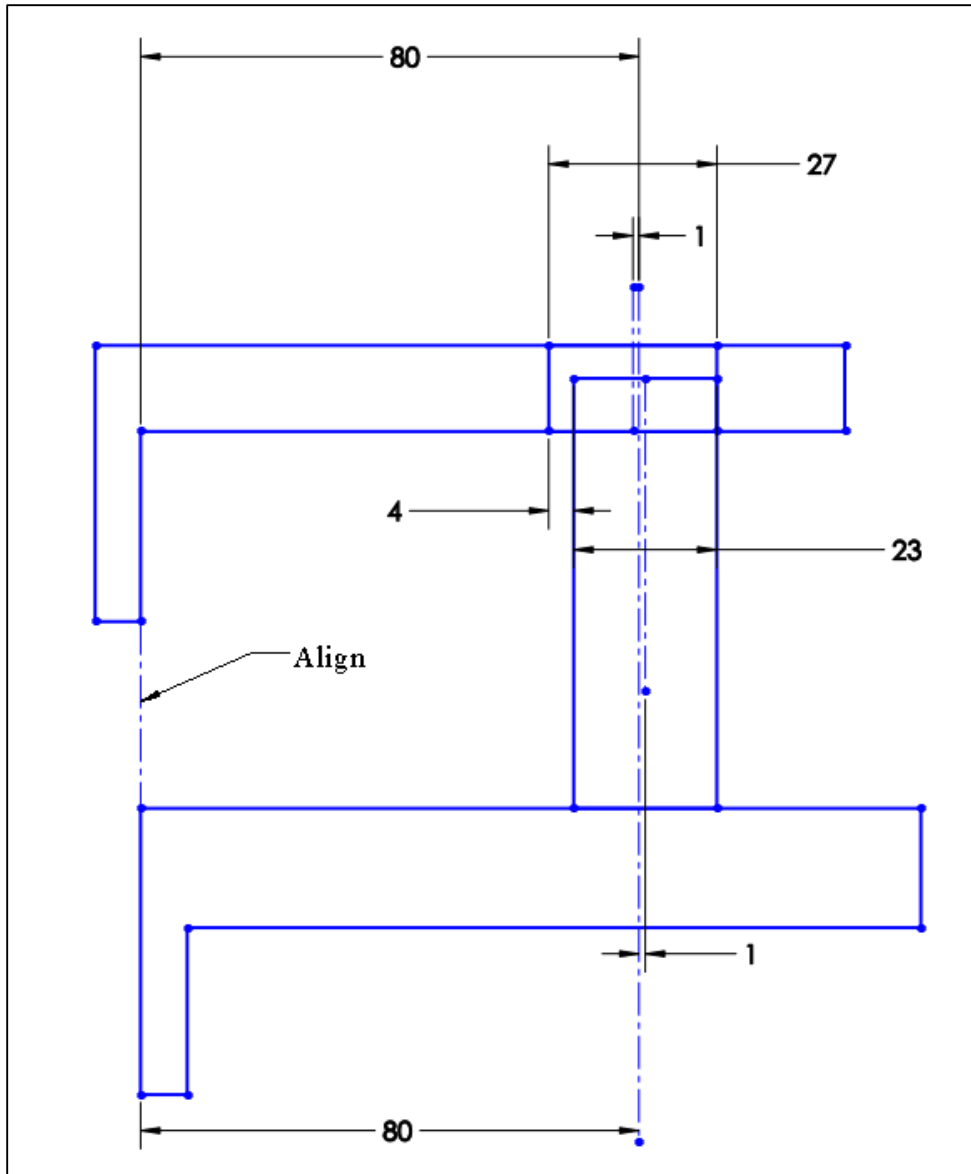


Figure 8-35. Sketch assembly of the parts leading to maximum gap in the fit

We can always create the 3D solid model of the two parts with the dimensions that lead to minimum or maximum gap in order to check the extreme assembly gaps. Figure 8-36 shows such a model with the related model values.

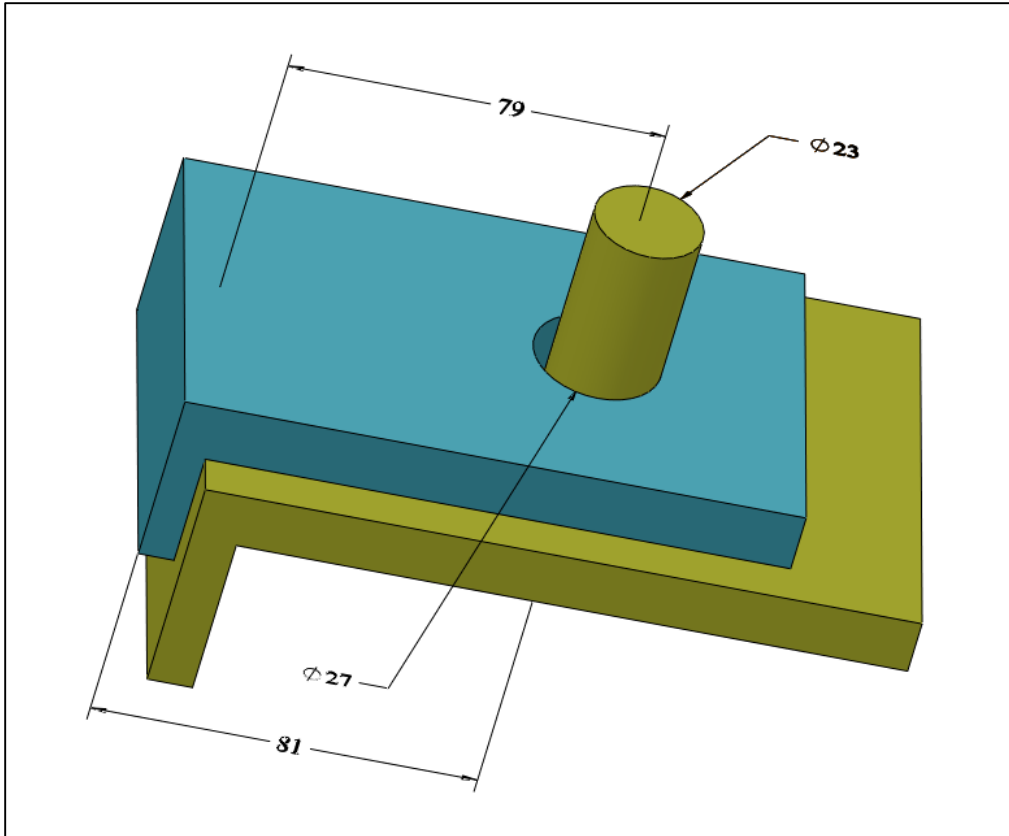


Figure 8-36. 3D assembly of the parts leading to maximum gap in the fit

Figure 8-37 can help seeing the maximum gap from the top view. The vectors represent the dimensions and can be used to calculate the maximum gap.

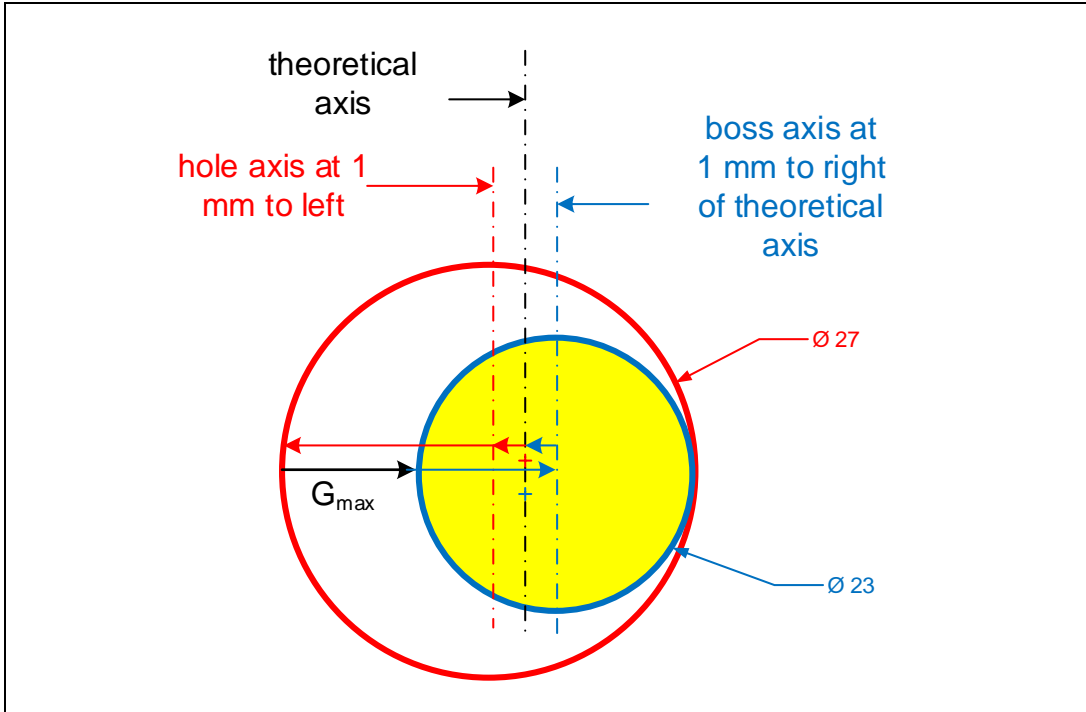


Figure 8-37. Feature sizes and axis deviations at LMC when  $\textcircled{M}$  modifier is used

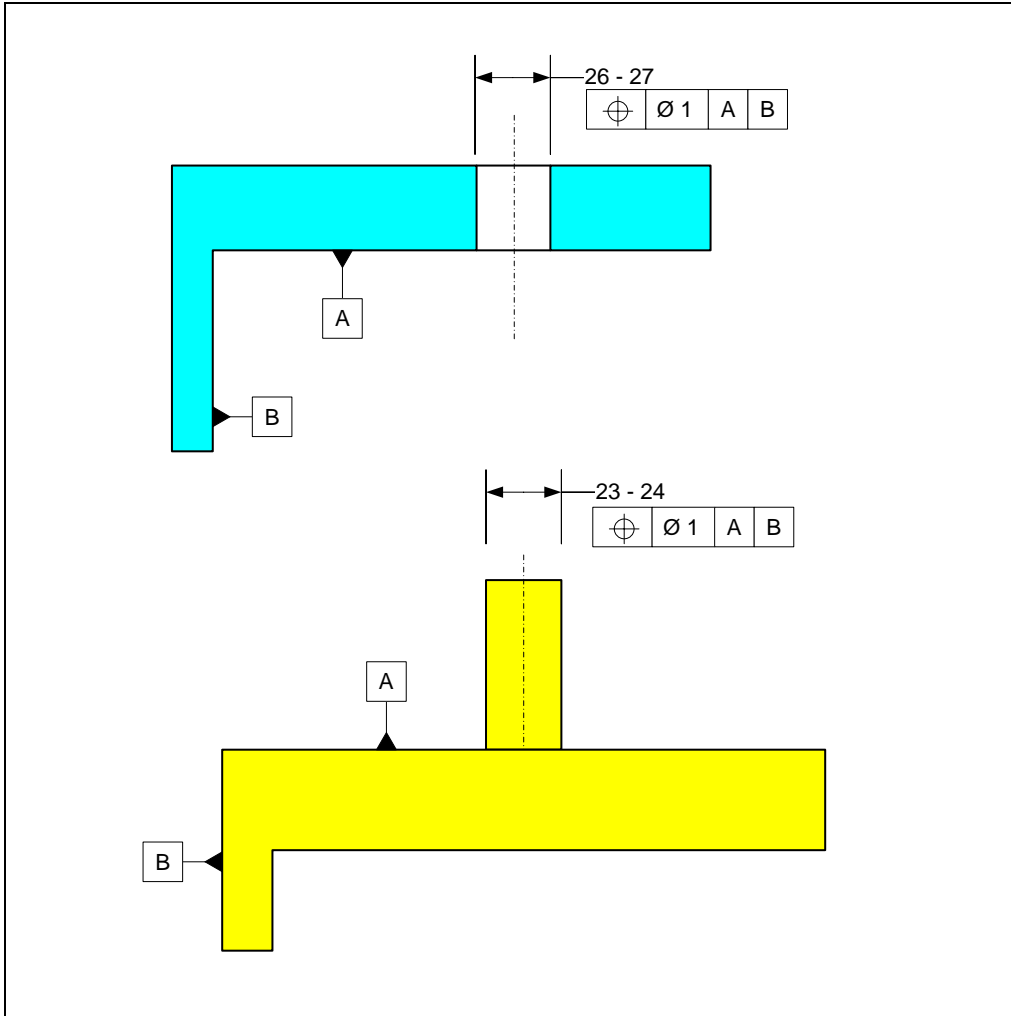
The features are both at their LMC limits of size. The hole and pin are allowed a maximum deviation of 1 mm at LMC leading to a maximum possible axial misalignment of 2 mm. It is easy to form the following tolerance vector loop relationship:

$$G_{max} + (23/2) - (1) - (1) - (27/2) = 0$$

From which:

$$G_{max} = 4 \text{ mm}$$

*Using no modifiers (RFS):* If we use the same size limits and position tolerance values but specify the position tolerances RFS, as shown in Figure 8-38, the fit boundary sizes remain as 25 mm - the same as with the MMC specification. Therefore, the fit has a minimum gap of zero. Note that the subject feature in an RFS specification is the feature axis. The fit boundary is an indirect result of size and axis location deviation.



**Figure 8-38. Parts set up for location-constrained fit with position tolerance RFS**

The maximum gap occurs when the hole is at LMC value of 27 mm and the boss is also at LMC value of 23 mm. Figure 8-39 shows the maximum gap situation.

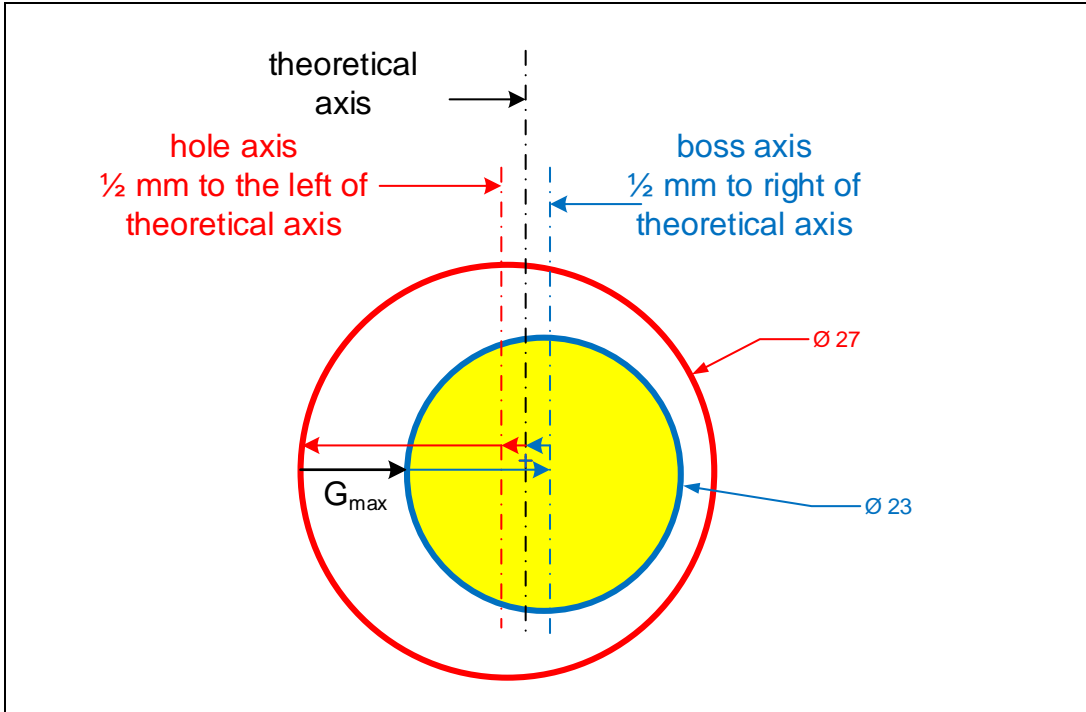


Figure 8-39. Feature sizes and axis deviations at LMC when no modifier is used

The only difference between this and the previous MMC specified example is that the allowed maximum deviation for either feature is 0.5 mm rather than 1 mm. Therefore, the maximum possible axial misalignment between actual axes is 1 mm. The maximum gap is easily calculated from the tolerance loop equation

$$G_{\max} + (23/2) - (1/2) - (1/2) - (27/2) = 0$$

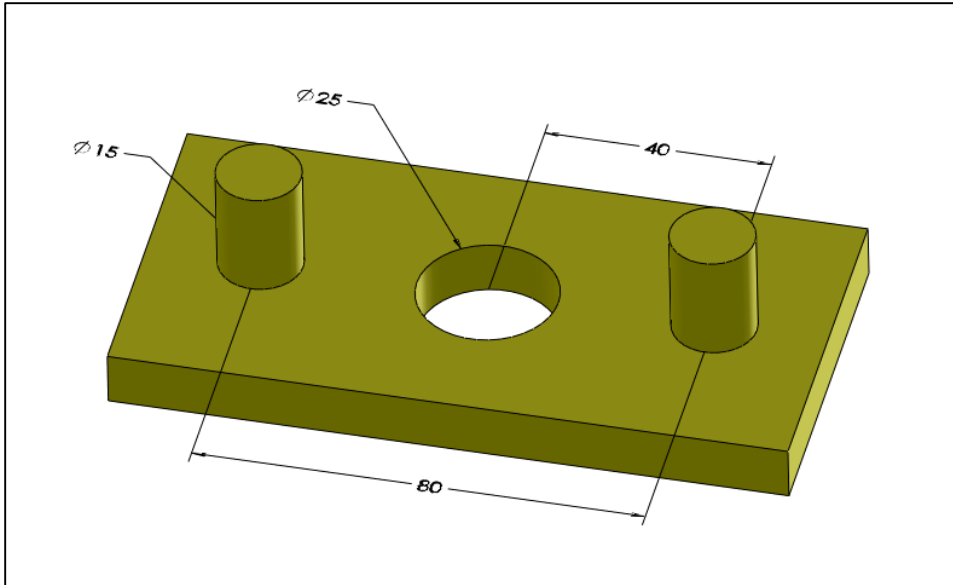
This expression leads to

$$G_{\max} = 3 \text{ mm}$$

From this analysis it is clear that the position tolerance specifications at RFS leads to a smaller maximum gap and axial misalignment compared to a  $\textcircled{M}$ -modified specification. This happens because the RFS specification keeps the features more centered when features are at LMC. In two-part fits we often do not care if the features are more centered - we simply care about fit. For that reason, the  $\textcircled{M}$ -modified specification is the better choice in two-part fits as it leads to increased manufacturing tolerances. The RFS must be used, however, when the feature sizes need to be controlled for other functional reasons.

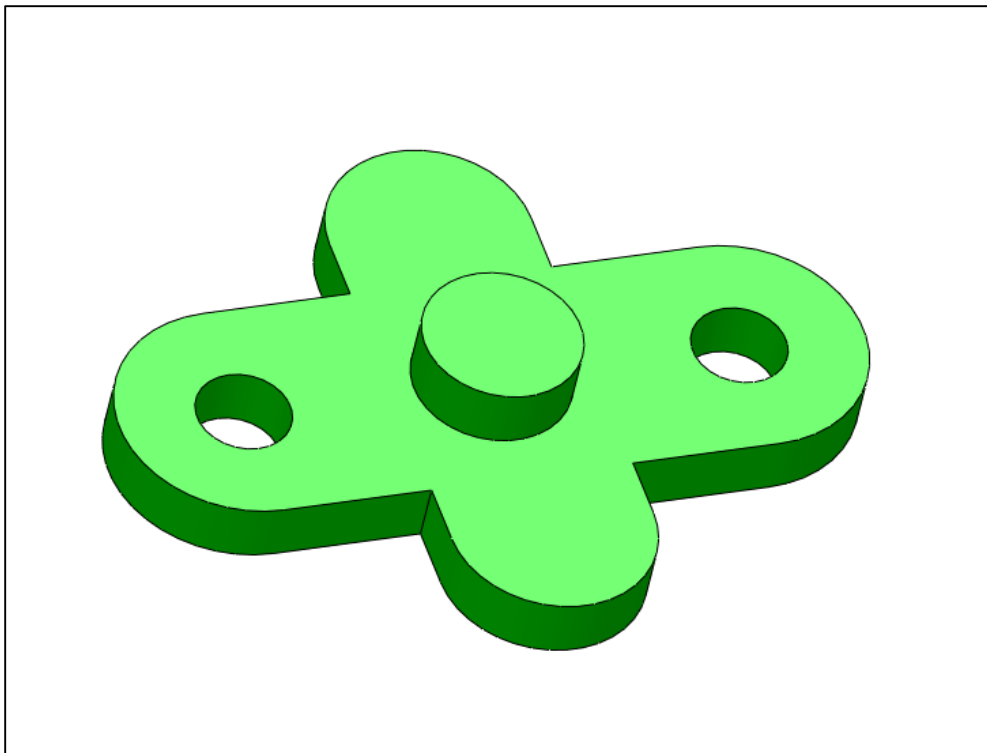
### Exercise Problems

1. Consider a plate with a center hole and two pins as shown in Figure 8-40.



**Figure 8-40.** A plate with a center hole and two pins

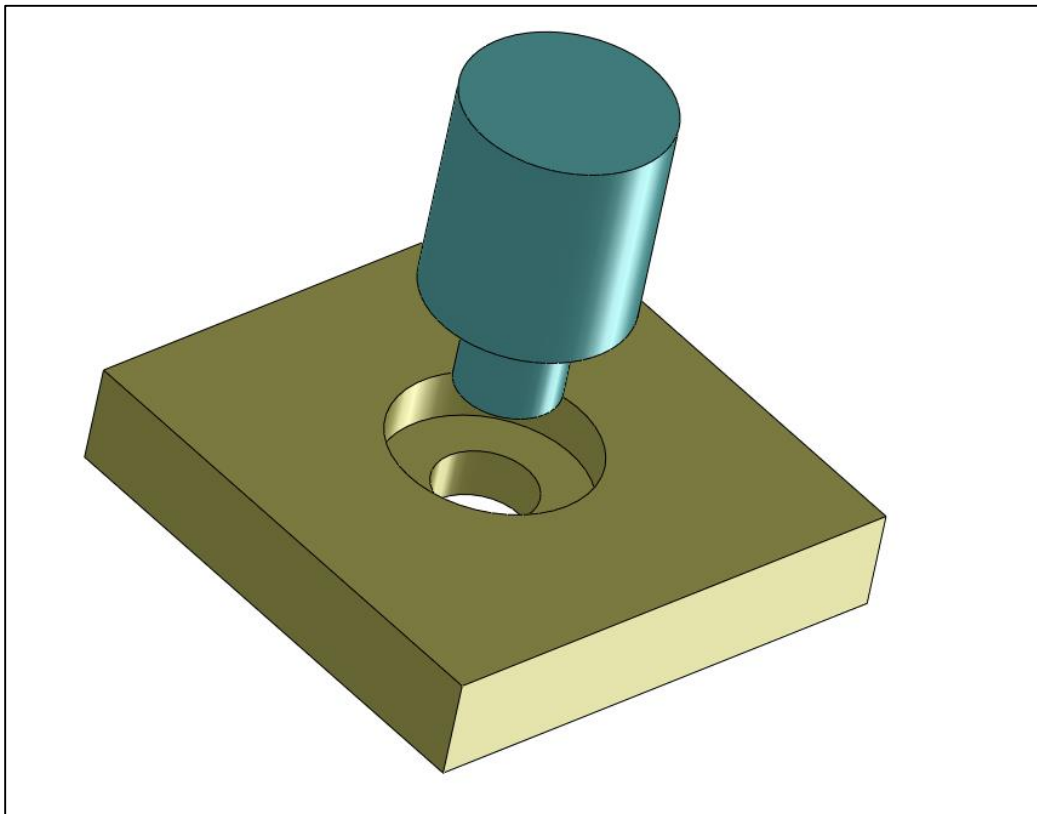
Model this part on a CAD system and create a drawing. Specify the center hole to have size limits of 25H9. Specify the two pins to have size limits of 15h12. The pattern of two pins is the subject feature. This plate is fitting a plate with a center pin and two holes as shown in Figure 8-41.



**Figure 8-41.** A plate with a center pin and two holes

For this plate use size limits of 25h10 for the center pin and 15H12 for the two holes. Complete the tolerancing information for the fitting features including identification and control of datum features.

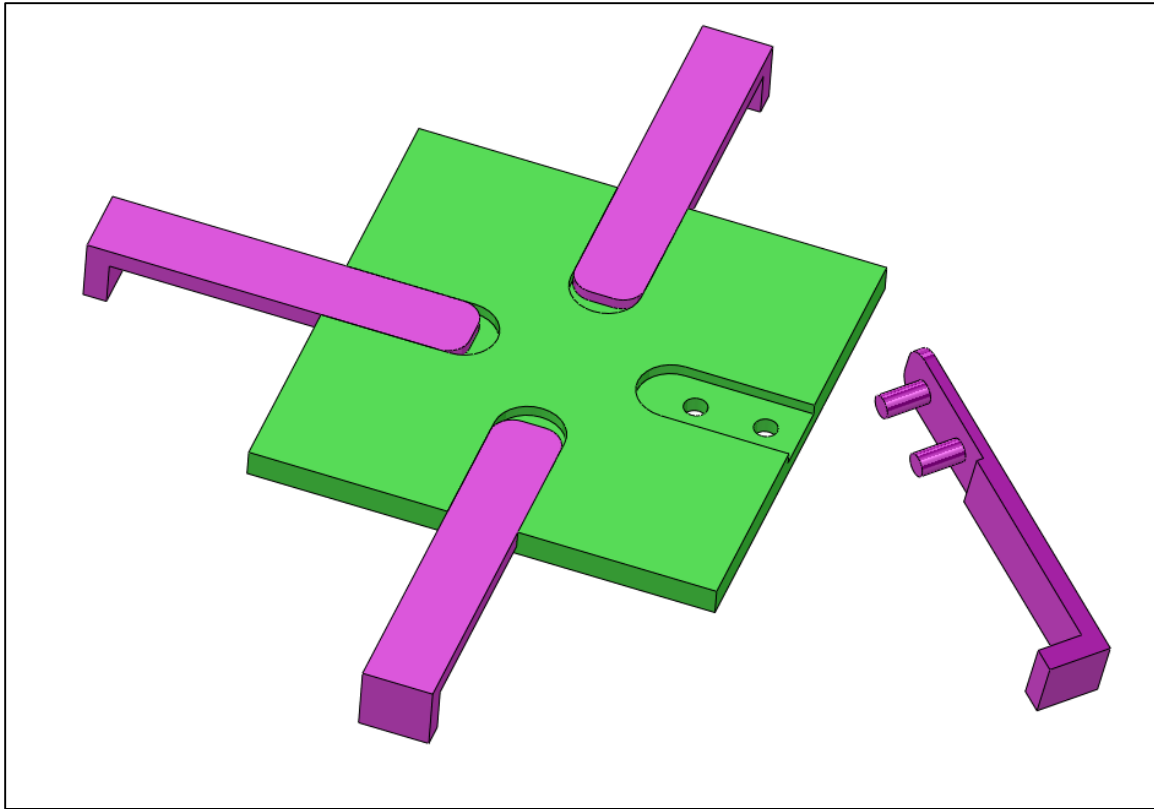
2. After designing the tolerances for the Exercise Problem#1, model the two parts on a CAD system with dimensions leading to worst conditions for fit. Put the two parts together into an assembly and constrain them as intended by design and verify that a zero gap fit is assured.
3. Complete the tolerancing of the two parts in Exercise Problem#1 but this time treat the pattern of two holes and pins as the datum feature while the center features become the subject features. Are the acceptable geometries allowed by the two scheme of tolerancing different?
4. Consider the simultaneous fit of two coaxial features as shown in Figure 8-42.



**Figure 8-42. Fit of two coaxial features**

The nominal dimensions of the larger cylinders are 40 mm and the smaller cylinders are 20 mm. We would like to tolerance the parts to assure assembly. In this





**Figure 8-44. Fit of four separate parts to a plate**

The pins and holes have 10 mm nominal size and the width of the rail and slot are 30 mm. The rest of the dimensions are up to you. Model the parts in a CAD system and create complete production drawings for the two parts. Assume milling process tolerances apply.

8. Find an actual example of a location-constrained fit. Take a picture and explain why the fit is a location-constrained fit. Create a model of the relevant features and tolerance them for fit.

# Chapter 9

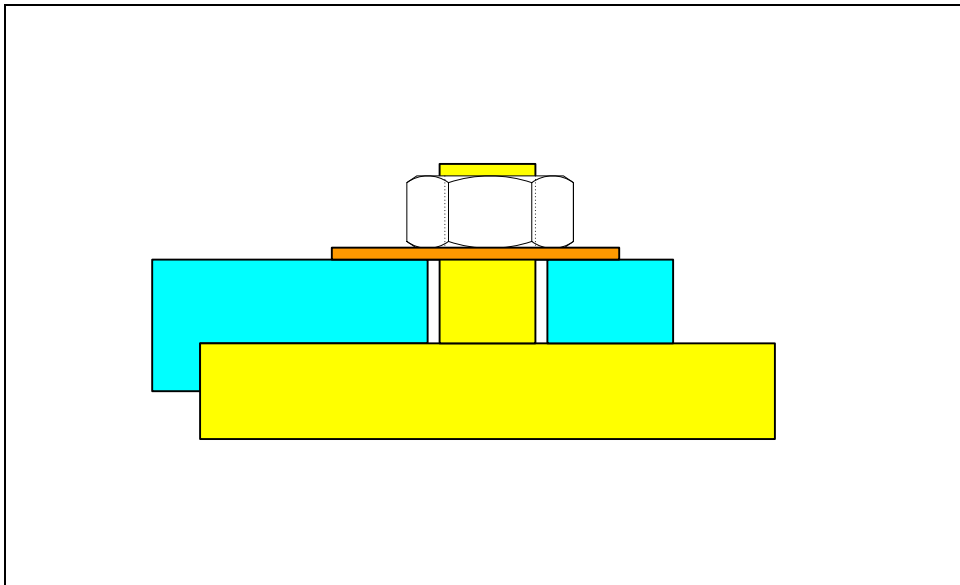
## Assemblies with Threaded Fasteners

### 9.1. Overview

The fit analysis of general multipart assemblies will be presented in Chapter-11. The fit of some common three-part assemblies, however, can be analyzed by extending the methods presented so far for two-part assemblies. This chapter presents the formulas needed to assure fit of some common three-part assemblies particularly fastener-related assemblies including assembly with threaded studs and nuts, assembly with threaded holes and screws, and assembly with loose bolts and nuts.

### 9.2. Fits using threaded studs or screws

Figure 9-1 shows a simple assembly of two plates with a threaded stud and a nut fitting a clearance hole. In this example the pin is an integral part of the plate and is threaded. This situation represents an assembly of two directly fitting parts. The figure shows a single feature but in most cases it is a part of a pattern of features.

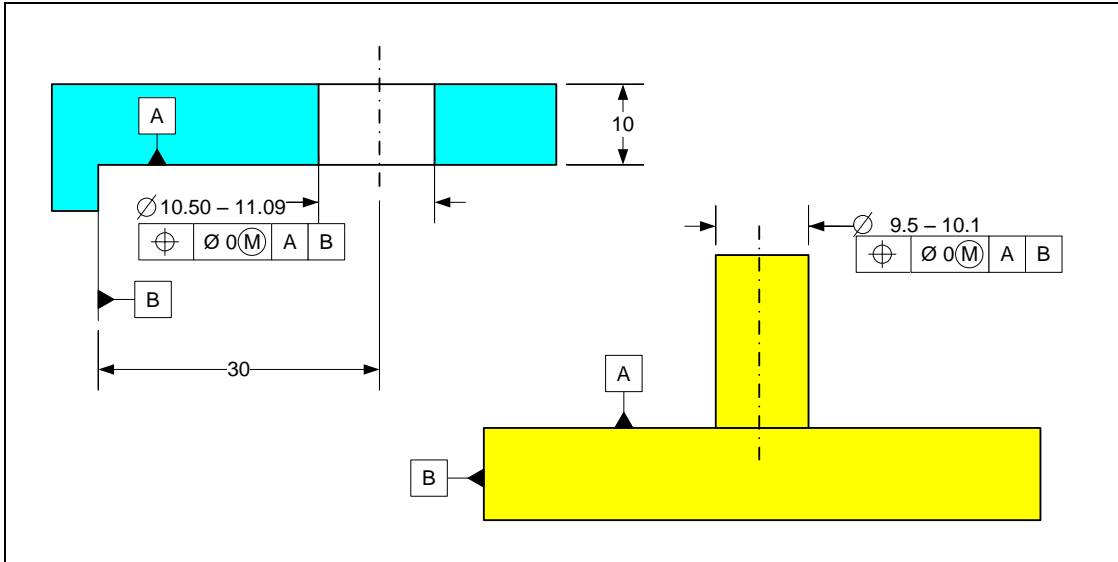


**Figure 9-1. A two-part plate assembly with a threaded stud and a nut**

To assure fit, the usual fit formula applies and the position tolerances can be obtained from

$$T_H + T_F \leq H_{\min} - F_{\max}$$

The tolerancing scheme for this example is shown in Figure 9-2. In this chapter we will use more realistic tolerance values.



**Figure 9-2. Size and position tolerances necessary to assure fit**

To find the size limits for the clearance hole, we select size limits that are consistent with drilling tolerances. Drilling is often the process of choice for making fastener holes. In this example, the designer can set up hole tolerances based on an 11 mm drill size. The total size tolerance for this drilling operation is 0.09 mm. Drills are designed to create holes that are at or slightly larger than their nominal sizes. Therefore instead of specifying  $11 \pm 0.04$  mm for the clearance hole size tolerance, we should specify a range of 11.00 – 11.09 mm. When holes are intended to be created by other processes, it is usually best to use symmetric size tolerance values around the nominal size. The fit relationship is determined by the fit formula

$$T_H + T_F \leq H_{\min} - F_{\max}$$

Assuming equal position tolerances for hole and stud features and setting the MMC size of the stud to be  $F=10$  mm leads to

$$T = \frac{1}{2} (11 - 10) = 0.5$$

We can specify a position tolerance of  $T_H = T_F = 0.5$  mm for both the clearance hole and the stud. This position tolerance is well within the accuracy of the drilling process. It is best, however, to specify a zero position tolerance specification for the clearance holes by combining the position tolerance with the MMC size of the hole

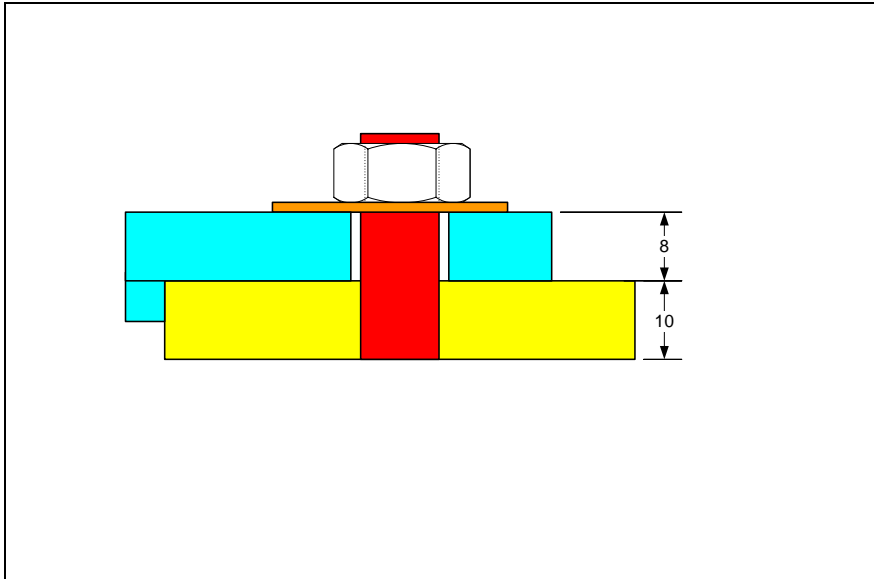
$$H_0 = 11 - 0.5 = 10.5 \text{ mm}$$

The hole size limits become 10.5 - 11.09 mm. The combined size and position tolerance for the hole is 0.59 mm.

When the size and position tolerance of the hole are specified separately, the equivalent specification requires size limits of 11.00 – 11.09 mm and position tolerance of 0.5 mm. For the stud, the size tolerance is assumed to be 0.1 mm. Using zero position tolerance for the stud results in  $F_0 = 9.5$  mm. The LMC size of the stud becomes 10.1 mm. The combined size and position tolerance for the stud is 0.6 mm.

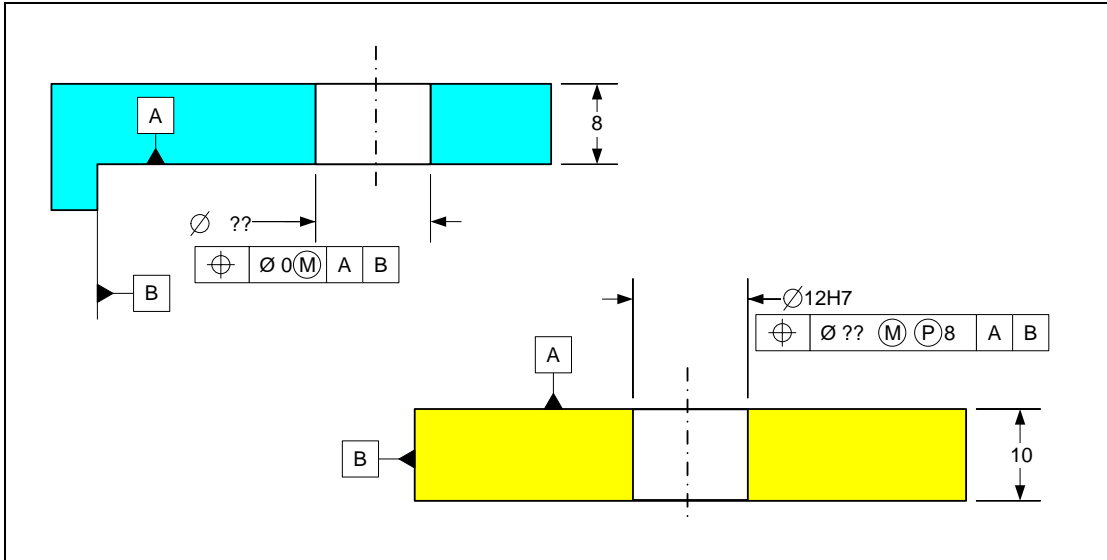
### 9.3. Fits using threaded press-fit studs

Making metallic pins as integral parts of plates is difficult and costly. Machine designers rarely design such features on metallic parts. Instead, plates are designed with holes to which separate pins are press fitted. The more common design for the assembly of the previous example looks as shown in Figure 9-3. This situation is similar to the assembly of plates with threaded holes and cap screws. In fact, the stud and the nut together appear like a screw.



**Figure 9-3. A three-part assembly of two plates with a press-fitted threaded stud**

The fit in this problem is no longer an assembly of two directly fitting parts. However, there is a special tolerance specification that allows a designer to tolerance this assembly as if the pin was an integral part of the plate it is pressed into. This special specification, known as the *projected tolerance zone*, requires that the position tolerance statement be applied not to the hole but to a pin of certain height inserted into the hole. The symbol for the projected tolerance zone designation is a circled letter P. The letter P stands for “Projected” but you may think of the symbol P to refer to “Pin”. This means the position tolerance applies to a pin inserted into the holes and not the hole itself. During inspection, real pins must be inserted into the holes and it is these pins that are the subject of the position tolerance statement. The tolerance statements that assure fit in this case are shown in Figure 9-4 for 12 mm fasteners with two unknown values to be determined.



**Figure 9-4. Format of position tolerances and size tolerances necessary to assure fit**

To assure a zero-clearance fit, the fit boundary of the clearance hole must be equal to the fit boundary of the pin that is inserted into the stud hole

$$H_{c,\min} + T_{Hc} = F_{\max} + T_F$$

Where  $H_{c,\min}$  represents the MMC size of the clearance hole and  $F_{\max}$  is the maximum size of the pin.  $T_{Hc}$  is the position tolerance of the clearance hole. The fit formula is then

$$T_{Hc} + T_{Hs} \leq H_{\min} - F_{\max}$$

$T_F$  is the position tolerance of the pin which is the same as the position tolerance of the stud hole  $T_{Hs}$ . When position tolerances for the clearance hole ( $T_{Hc}$ ) and stud hole ( $T_{Hs}$ ) are selected to be equal, the formula becomes

$$T_H \leq \frac{1}{2}(H_{\min} - F_{\max})$$

This formula is called the *fixed fastener formula* and it also applies to plates fastened together using cap screws and tapped holes. We can select a 12.5 mm drill for the clearance hole and complete the specifications based on this drill size. The size tolerance for drilling process for a 12.5 mm size clearance hole is 0.1 mm which results in size limits of 12.5 – 12.6 mm. Using the fixed fastener formula, the position tolerance needed to assure fit is

$$T_H = T_{Hc} = T_{Hs} = \frac{1}{2} (12.5 - 12) = 0.25 \text{ mm}$$

The position tolerance is well within the drilling position accuracy. We can specify position tolerances of 0.25 mm for the clearance and stud hole. It is better to convert the clearance hole specifications to zero position tolerance format by combining the hole MMC size with the required position tolerance

$$H_0 = 12.5 - 0.25 = 12.25 \text{ mm}$$

The stud hole specification, however, cannot use the zero position tolerance format.

Figure 9-5 shows the complete specifications.

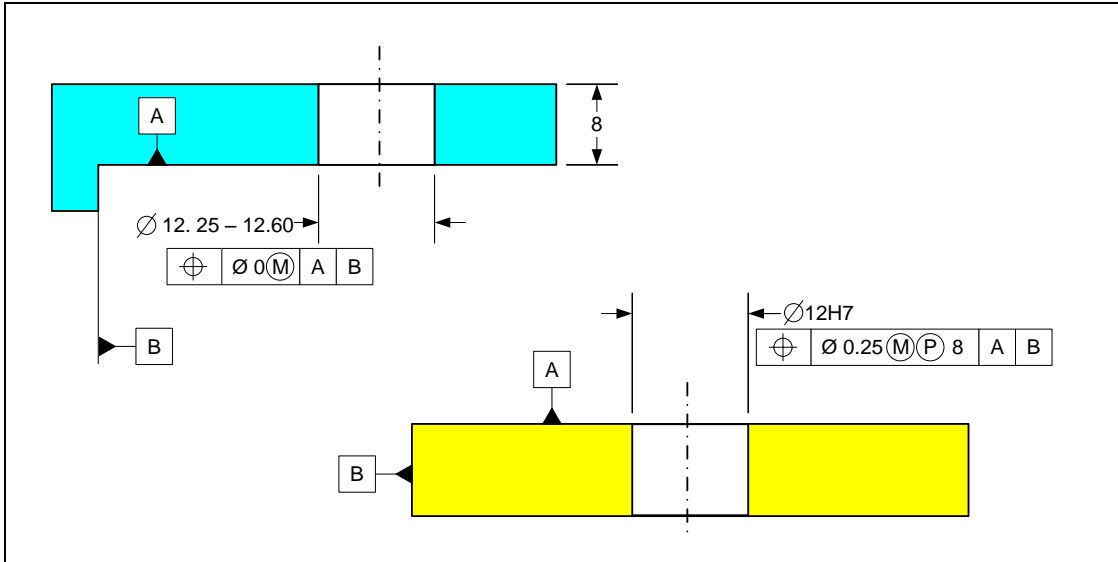


Figure 9-5. Complete specifications for the assured fit of plates with a press-fit threaded stud

The treatment is exactly the same whether there is one fastener or a pattern of fasteners.

#### 9.4. Assembly with cap screws and threaded holes

An alternative to press-fit studs and also a more common way of attaching two plates is the use of cap screws and tapped holes. This situation is shown in Figure 9-6

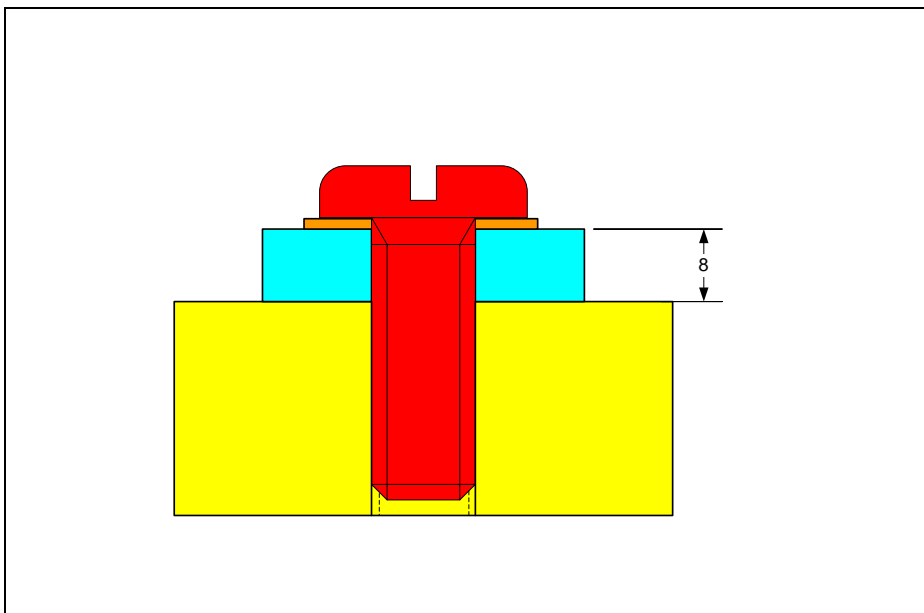
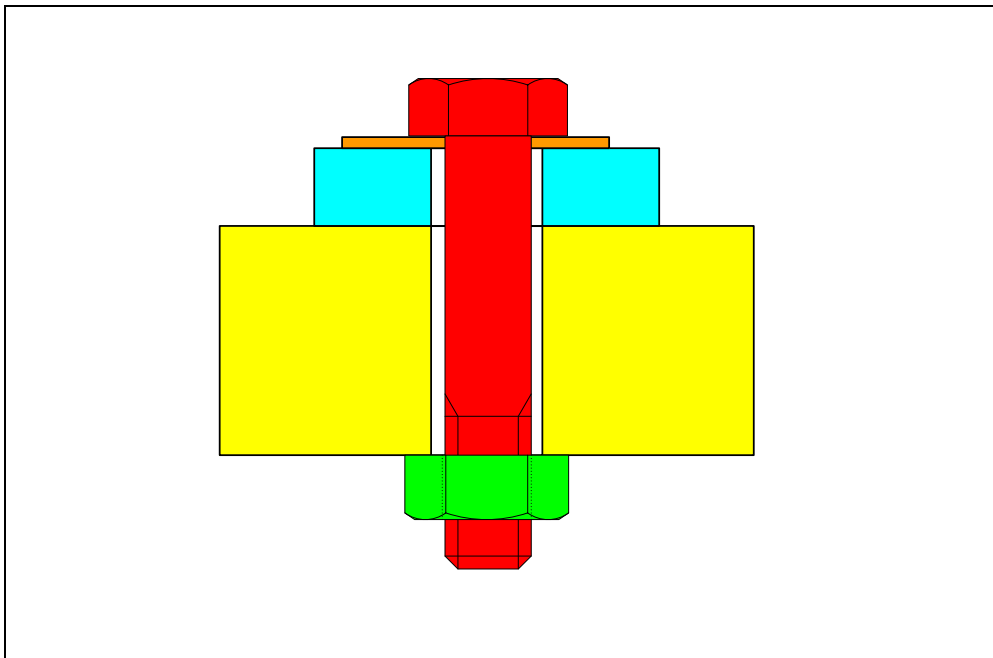


Figure 9-6. Assembly of plates using threaded holes and cap screws

When we compare the role of the screw in Figure 9-6 with that of the threaded stud in Figure 9-3 we can see that they behave similarly. The only difference in specification is that the standard thread designation such as M10 x 1.5 would be used for the threaded hole instead of the size limits 10H7 for the press-fit stud hole. Some designers specify the height of projection to be slightly more than the thickness of the plate with clearance holes to create added margin for the slight tilt of screw head.

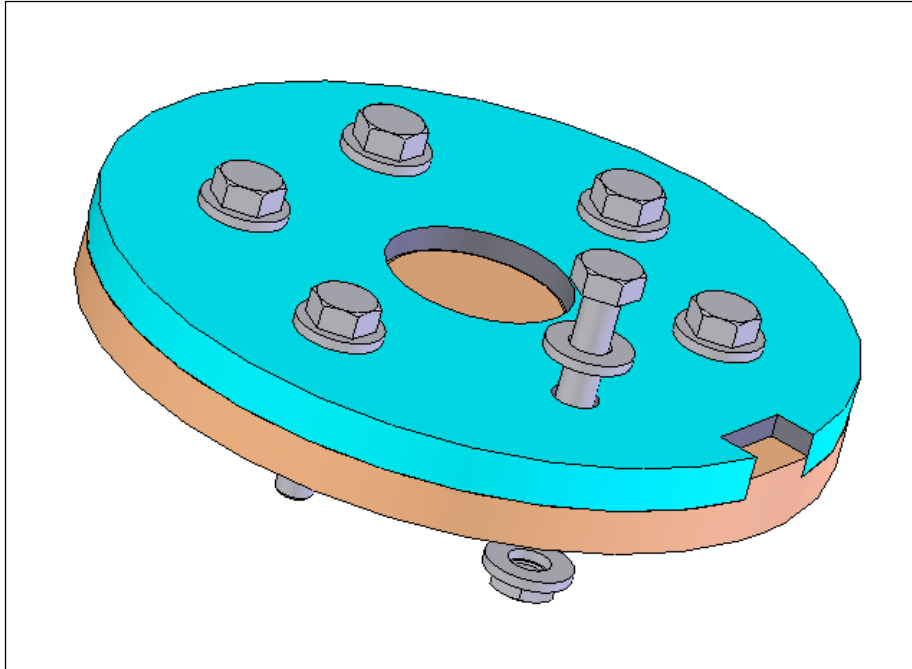
## 9.5. Assembly of two plates with loose bolts and nuts

Another three-part assembly that frequently occurs in application is the assembly of two plates with loose bolts and nuts such as the one shown in Figure 9-7. The figure shows a single bolt but in most cases a pattern of bolts is used.



**Figure 9-7. Assembly of plates using loose bolts and nuts**

In this assembly, the bolt is loose and fits through clearance holes while the bolt shoulder rests on the top surface of the hole or a washer. To illustrate the method of tolerance specification for this application, we use the assembly in Figure 9-8 assuming 10 mm loose bolts.



**Figure 9-8. Plates fastened together using a pattern of loose bolts and nuts**

The assembly of the bolts with clearance holes in the two plates creates a three-part assembly for which we need to use a more general tolerance analysis method in order to derive the fit formula. This more general analysis method would be presented later in Chapter-11 on tolerance analysis. The result of the analysis is shown in the following fit formula:

$$T_{H1} + T_{H2} \leq (H_{1\min} - F_{\max}) + (H_{2\min} - F_{\max})$$

In this formula,  $T_{H1}$  and  $T_{H2}$  are the position tolerances of the clearance holes,  $H_{1\min}$  and  $H_{2\min}$  are the MMC sizes of the clearance holes, and  $F_{\max}$  represents the fit boundary of the bolt which is usually its maximum shank diameter. Clearance holes often have identical specifications leading to the more common formula

$$T_H \leq H_{\min} - F_{\max}$$

This formula is called the *floating fastener formula*. A direct comparison with the fixed fastener formula,  $T_H \leq \frac{1}{2}(H_{\min} - F_{\max})$ , indicates that the clearance hole position tolerance values for floating fasteners can be twice as large as those for the fixed fastener case. This is because a loose bolt can relocate itself (or float) in the existing opening between the two plate holes while a fixed fastener is rigidly attached to the threaded hole or press-fitted into a plate.

Although the calculations are simple, the fastener applications are so common that automating the process is worth the effort. The FAP (Fastener Application Program) is a simple version of such a program. Figure 9-9 shows the dialog window that accepts the input parameters and suggests a solution for a fastener problem. The fastener size is 12 mm.

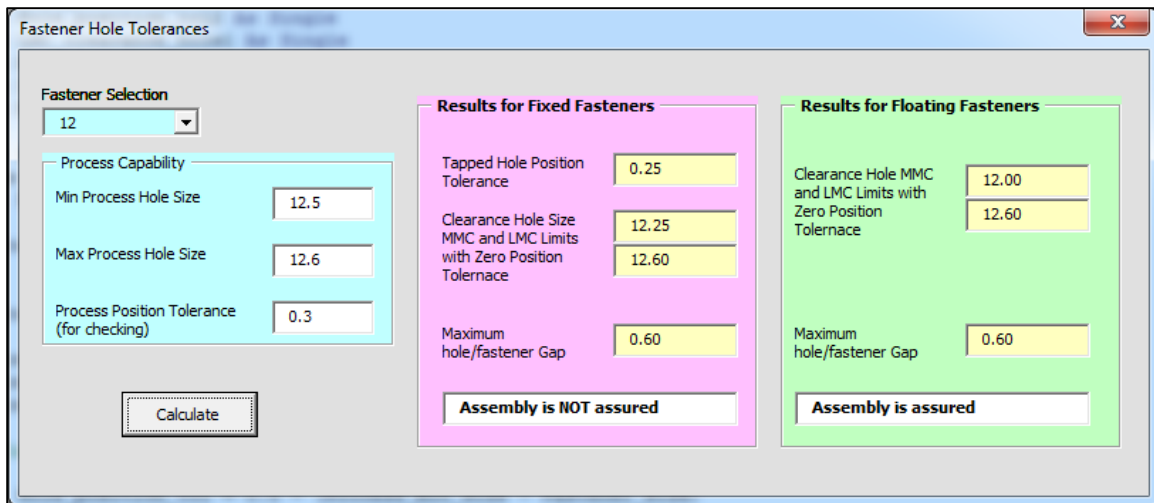
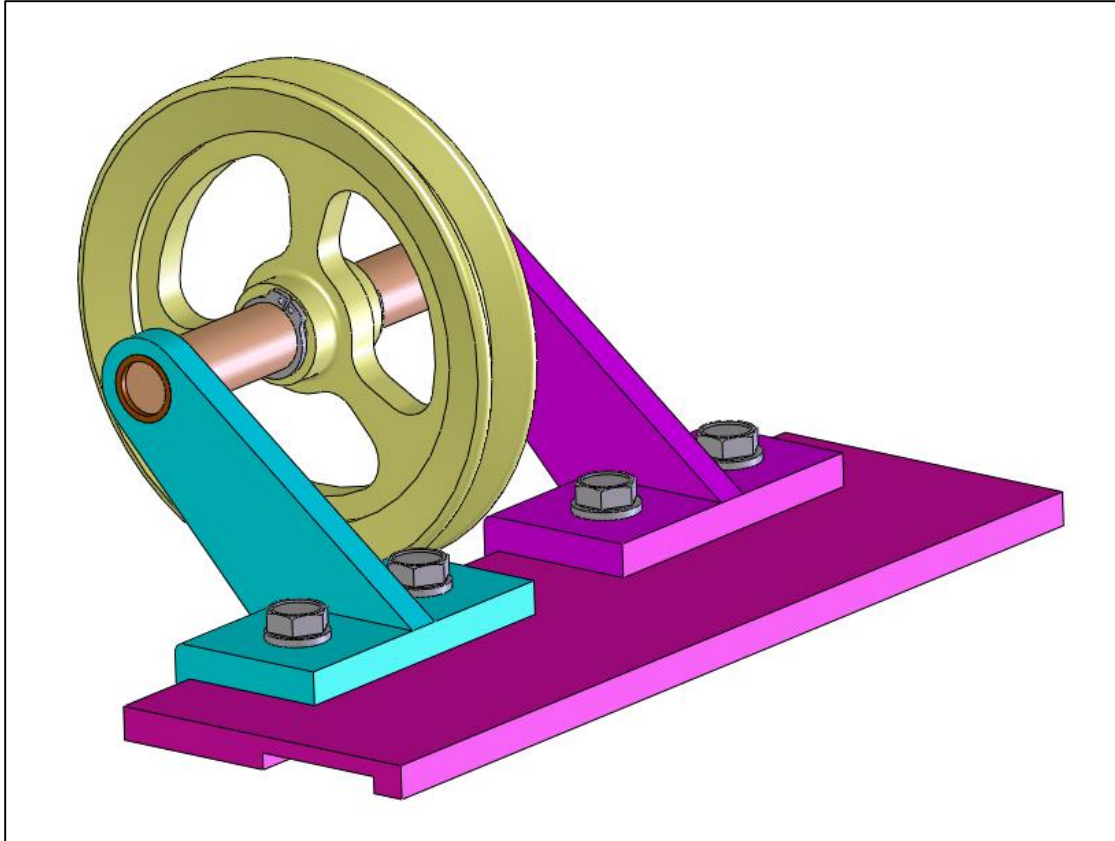


Figure 9-9. The dialog window of FAP showing the input parameters and the results

On the left-hand side is the fastener size and the minimum and maximum size of the hole associated with the hole-making process. In this case the process size limits are associated with a 12.5 mm drill. The manufacturing accuracy program (MAP) can be used to determine realistic size limits for drilled holes and an estimate of the position tolerance of the process. The process position tolerance, in this case 0.3 mm, would be used to check whether the chosen parameters assure free fit. The results show that the tolerance specifications do not assure fit for the fixed fastener case. This is because the required tapped hole position (0.25 mm) is smaller than the indicated 0.3 mm process tolerance. In this case we can increase the size of the drill to achieve a fit. For the floating fastener application the assembly is assured. When the fit is assured, it is also a good practice to try a smaller size drill to check if a better fit can be achieved. For example if initially a 13 mm drill is selected, the maximum fit gap would be 1.1 mm. Checking a 12.5 mm drill results in a better fit without additional costs. FAP uses equal position tolerances for all clearance holes.

## 9.6. Fastener applications - Example-1

Consider the offset arm assembly in Figure 9-10 in which two identical parts called arms fit a base plate with four cap screws. We are asked to specify the size and position tolerance of the clearance holes separately and not use zero position tolerance format.



**Figure 9-10. The offset arm assembly**

The arm and the base plate must fit together with standard M10 screws while the seating surfaces are in full primary contact and the locating edges are in secondary contact. The depth of the clearance holes as well as the tapped holes is 10 mm.

We first check the specifications for 10.5 mm drills. The size tolerance to be used with a 10.5 mm drill hole is 0.1 mm which will be divided as 10.49 – 10.59 mm to provide a little extra margin for worn out drills. We can check the fit using the fixed fastener formula

$$T_{Hc} + T_{Ht} \leq H_{min} - F_{max}$$

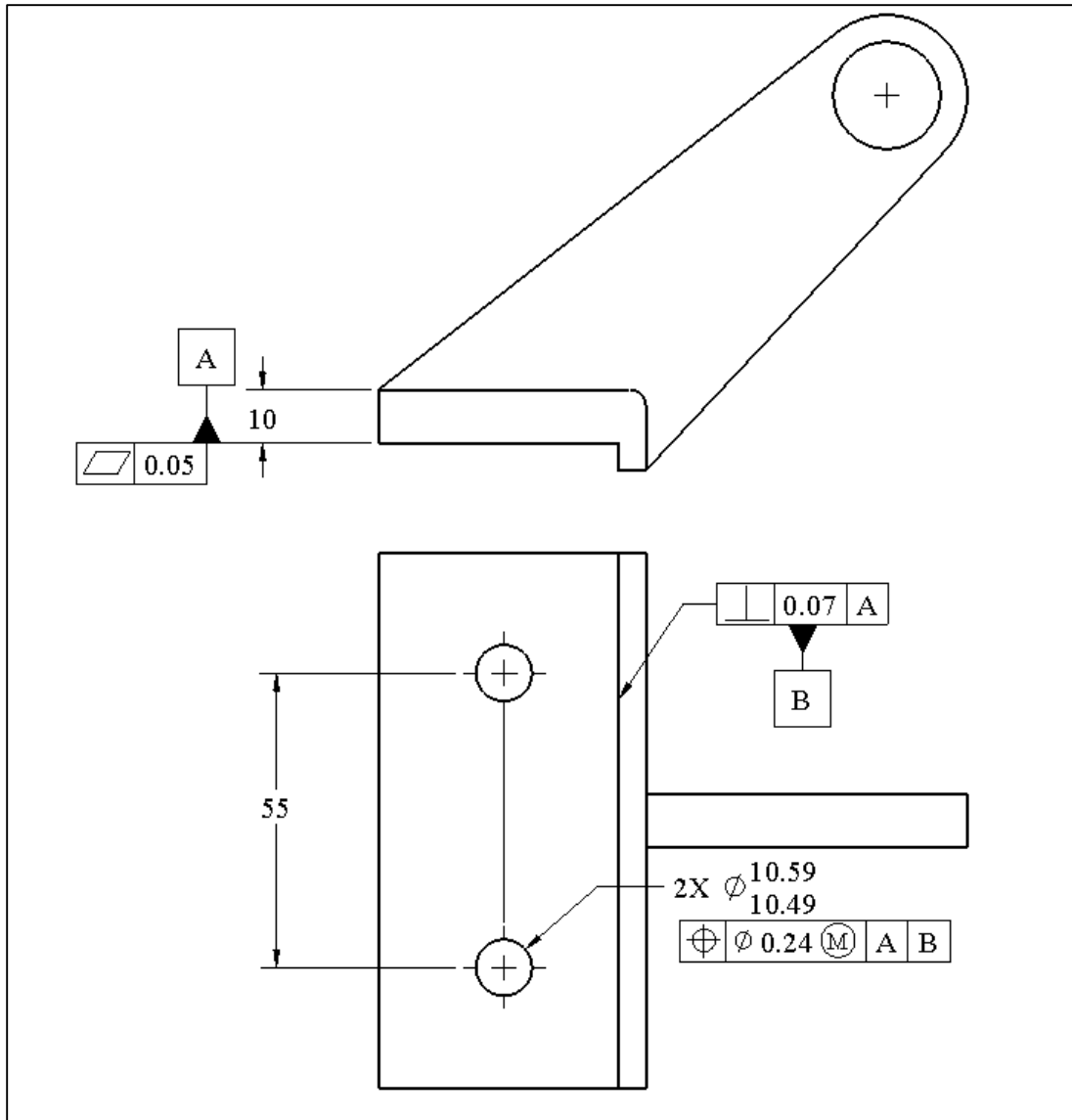
In this case

$$H_{min} - F_{max} = 10.49 - 10 = 0.49 \text{ mm}$$

Therefore

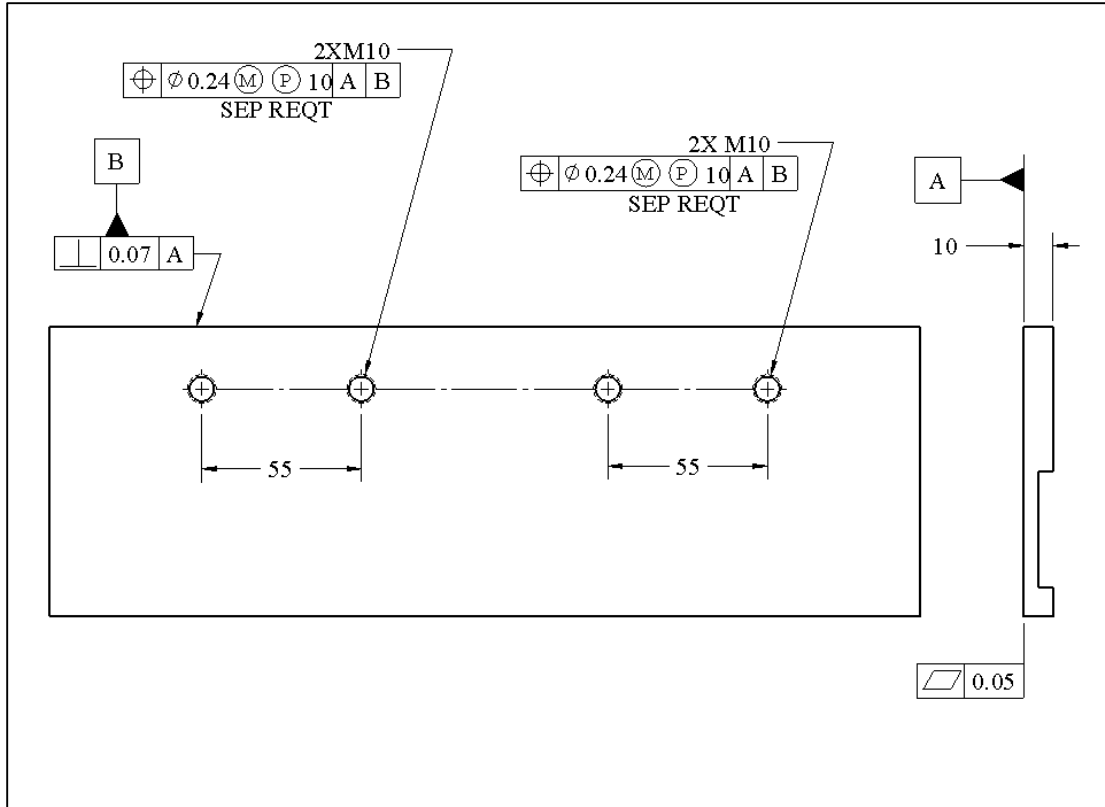
$$T_{Hc} + T_{Ht} = 0.49 \text{ mm}$$

We can divide the total position tolerance between the clearance and threaded hole and use 0.24 mm for each. The arm tolerances related to this fit are shown in Figure 9-11.



**Figure 9-11. Arm tolerances**

The pattern of two holes can shift up or down with more allowance because that relationship is not precision and its control is left to the default tolerances. The tolerances for the plate is shown in Figure 9-12.

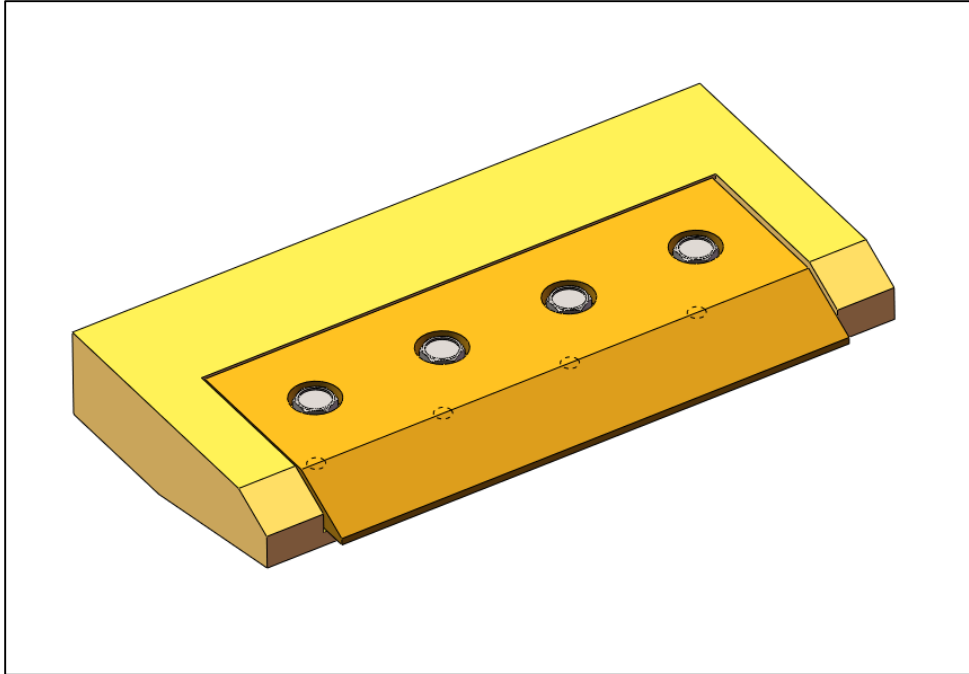


**Figure 9-12.** The SEP REQT designation means there are two patterns of two holes with separate fit requirements.

The patterns of two holes are treated separately because they fit to two separate parts. This is indicated by the note SEP REQT written beneath the tolerance control statement. This means that the two patterns of holes are gaged separately with two-hole gages rather than as one pattern of four holes. The result is that the distance between the two patterns is not controlled with precision. The GDT standard states that if two or more position tolerance statements use exactly the same datum frame for multiple feature patterns, the patterns are considered to be a single pattern unless SEP REQT is indicated.

## 9.7. Fastener applications - Example-2

Consider the blade and the blade holder assembly shown in Figure 9-13. This fit problem involves one primary orienting surface (seating surface), one secondary orienting and locating surface (back surface), one width feature fit (blade width) and a pattern of screw fits. The threaded holes in the blade holder accept 8-mm cap screws.



**Figure 9-13. Blade and blade holder**

The blade and the blade holder must fit together and get fixed with standard screws while the seating surfaces are in full primary contact and the back surfaces are in secondary contact. The fastener holes are intended to be drilled. We like to set up the tolerances for a fit with a maximum gap of 0.5 mm in the blade to blade holder width fit.

The blade width feature and the blade holder have an orientation-constrained fit. Using zero-perpendicularity tolerance for both features and a fit boundary of 140 mm, we get

$$H_0 = F_0 = 140 \text{ mm}$$

Using the maximum gap size of 0.5 mm and equal size tolerances on both width features leads to

$$H_{\max} = 140.25 \text{ mm}$$

$$F_{\min} = 139.75 \text{ mm}$$

The size tolerances are well within machining process capabilities. For the fit of cap screws we select a 8.5 mm drill size for clearance holes. For a 8.5 mm drill size the total size tolerance of 0.08 mm is attainable. The clearance hole size limits will be specified as 8.5 mm to 8.58 mm. For the fit of cap screws we use the fixed fastener formula

$$T_{Hc} + T_{Ht} \leq H_{\min} - F_{\max}$$

With  $H_{\min} = 8.5 \text{ mm}$  and  $F_{\max} = 8.0 \text{ mm}$ , the total position tolerances must be

$$T_{Hc} + T_{Ht} \leq 0.5 \text{ mm}$$

Using equal position tolerances for both tapped and clearance holes, we can select  $T_{Hc} = 0.25$  and  $T_{Ht} = 0.25 \text{ mm}$ . These position tolerances are within the positioning accuracy of the drilling process. We can also convert the clearance hole specifications to zero-position tolerance by expanding the hole size limits on the MMC side. For the clearance holes, the zero position MMC size limit becomes ( $H_0 = 8.5 - 0.25 = 8.25 \text{ mm}$ ) while the LMC limit remain as 8.58 mm.

## 9.8. Fastener applications - Example-3

The use of alignment pins is a common method of locating and orienting two parts with respect to each other. In this method the alignment features can be placed at the edges of parts leaving the middle for bearing holes or other functional features. Figure 9-14 shows a simple two-part gear housing assembly in which the center bearing holes are aligned with precision by locating them relative to two alignment pins and holes. Other functional features of the two parts such as gear pin holes are not shown to focus on the fastener application. The primary manufacturing process is die casting for these aluminum parts. The alignment pins are cast as integral parts of the housing piece.

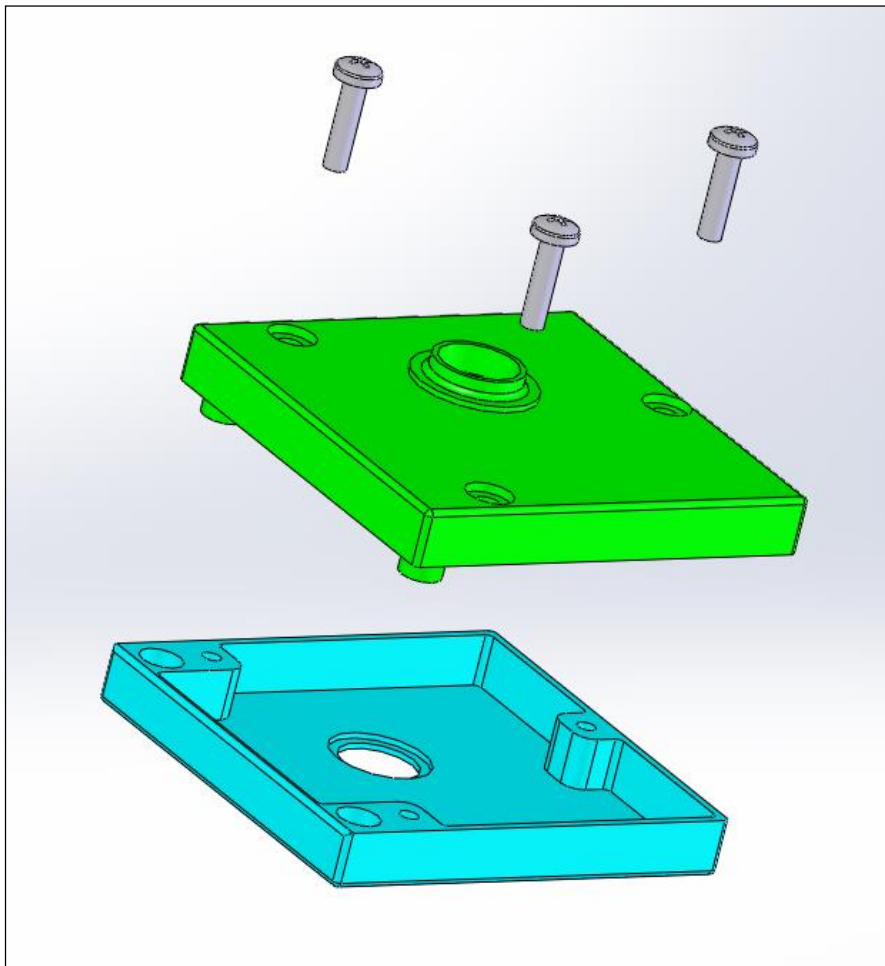
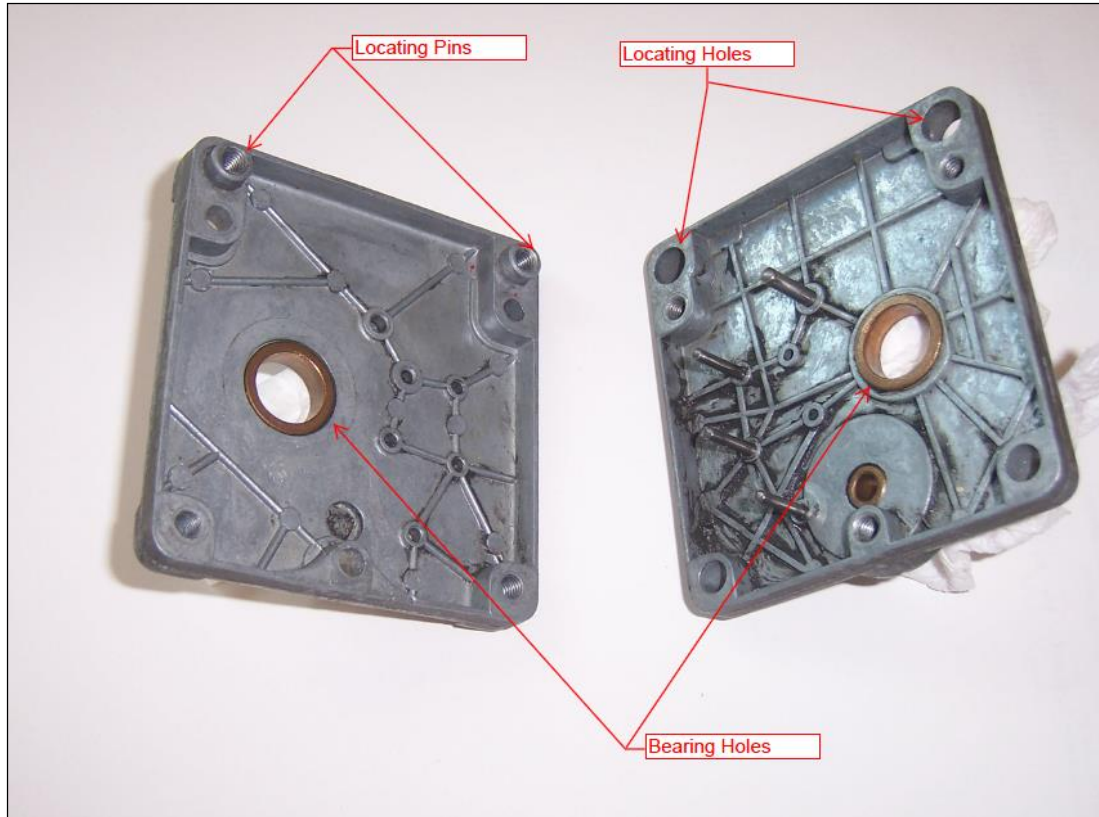


Figure 9-14. Gearbox housing

The physical assembly used for this example is shown in Figure 9-15.



**Figure 9-15. Picture of gearbox housing showing alignment holes and pins**

The nominal size of the locating pins and holes is 7.5 mm. The fasteners are M4 with a maximum shank diameter of 4 mm. We would like to determine the following:

- a) The size tolerances of alignment pins and alignment holes for a maximum possible play of 0.6 mm.
- b) The size tolerance of screw clearance holes and the position tolerance of tapped holes. For clearance holes, we use the zero-position tolerancing method. Die casting process accuracy is to be used for both tapped and clearance holes.

*Part-a)* Using zero-position tolerancing, the MMC size of the pins and the holes are equal to the size of the fit boundary selected to be  $H_0 = F_0 = 7.5$  mm. The difference in LMC sizes of pins and holes defines the maximum play and must be less than or equal to 0.6 mm. Therefore, the LMC size of the holes should be  $H_{\max}=7.8$  mm and the LMC size of the pins should be  $F_{\min}=7.2$  mm.

*Part-b)* Assuming a total size tolerance of 0.1 mm for the die casting process, the size limits for the clearance holes is set to  $4.5 \pm 0.05$  mm. Using the fixed fastener formula the total position tolerance for the tapped and clearance holes is

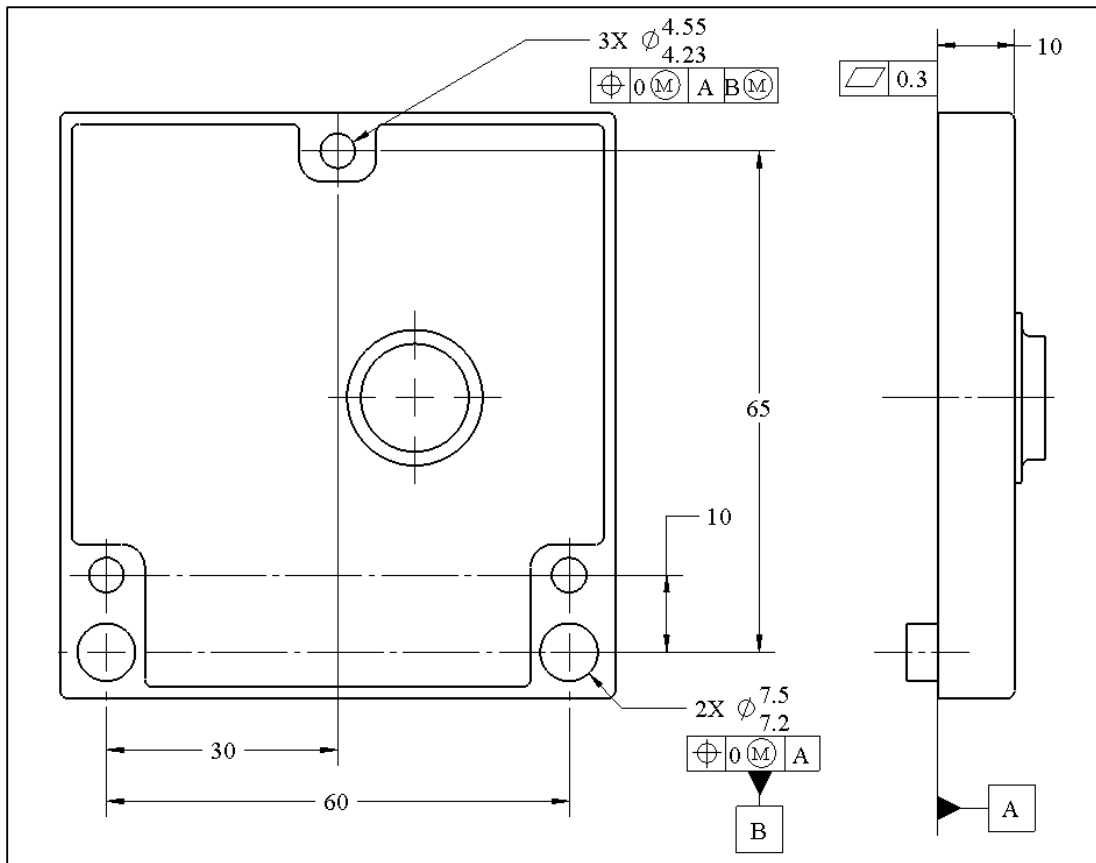
$$T_{Hc} + T_{Ht} \leq H_{\min} - F_{\max}$$

$$T_{Hc} + T_{Ht} \leq 4.45 - 4 = 0.45 \text{ mm}$$

Dividing equally, the required position tolerances are  $T_{Hc} = 0.22$  mm and  $T_{Ht} = 0.22$  mm. These position tolerances are within the accuracy of the die casting process. The

combined size and position tolerance for the clearance holes to be used with zero-position tolerance format becomes 4.23 – 4.55 mm. This is obtained by expanding the clearance hole size limits of 4.45 – 4.55 mm on the MMC side by 0.22 mm.

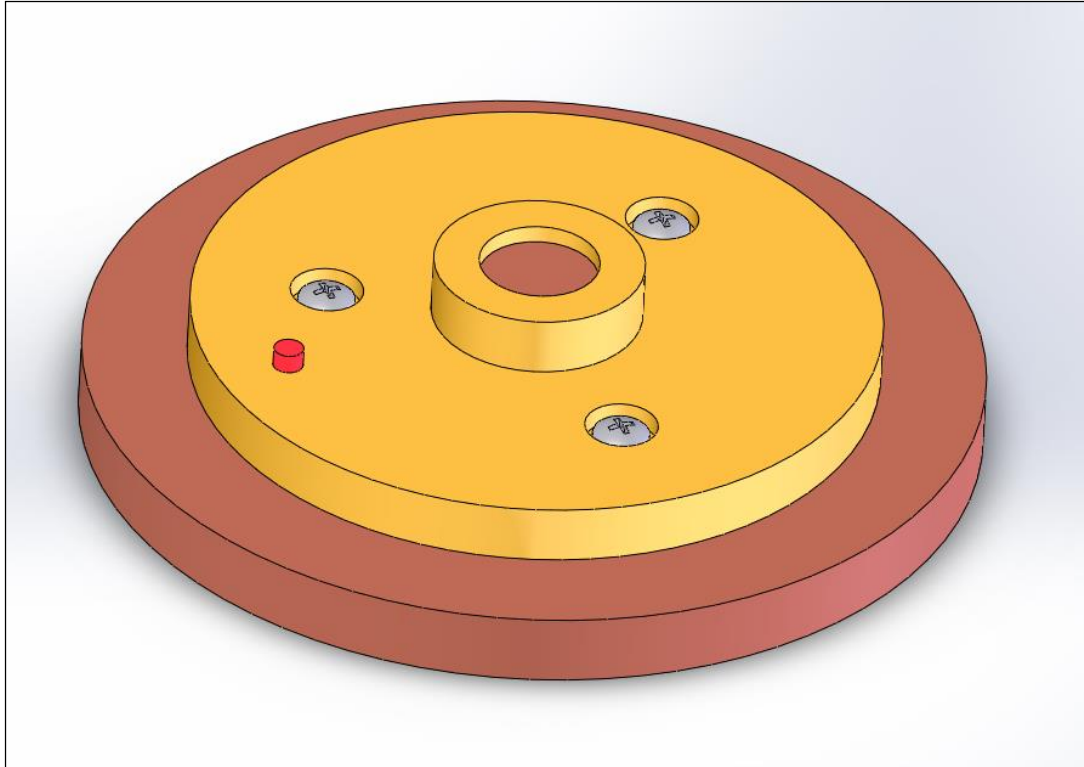
The tolerancing of the part with alignment pins is shown in Figure 9-16. The flatness value of 0.3 mm for the primary datum is chosen to be consistent with the die casting process and is considered acceptable for this slow-speed low cost gearbox.



**Figure 9-16. Tolerances for the part with locating pins**

The tolerancing of the part with the alignment holes looks very similar to the part with pins. Figure 9-17 shows the tolerancing of the part with alignment holes and threaded holes.





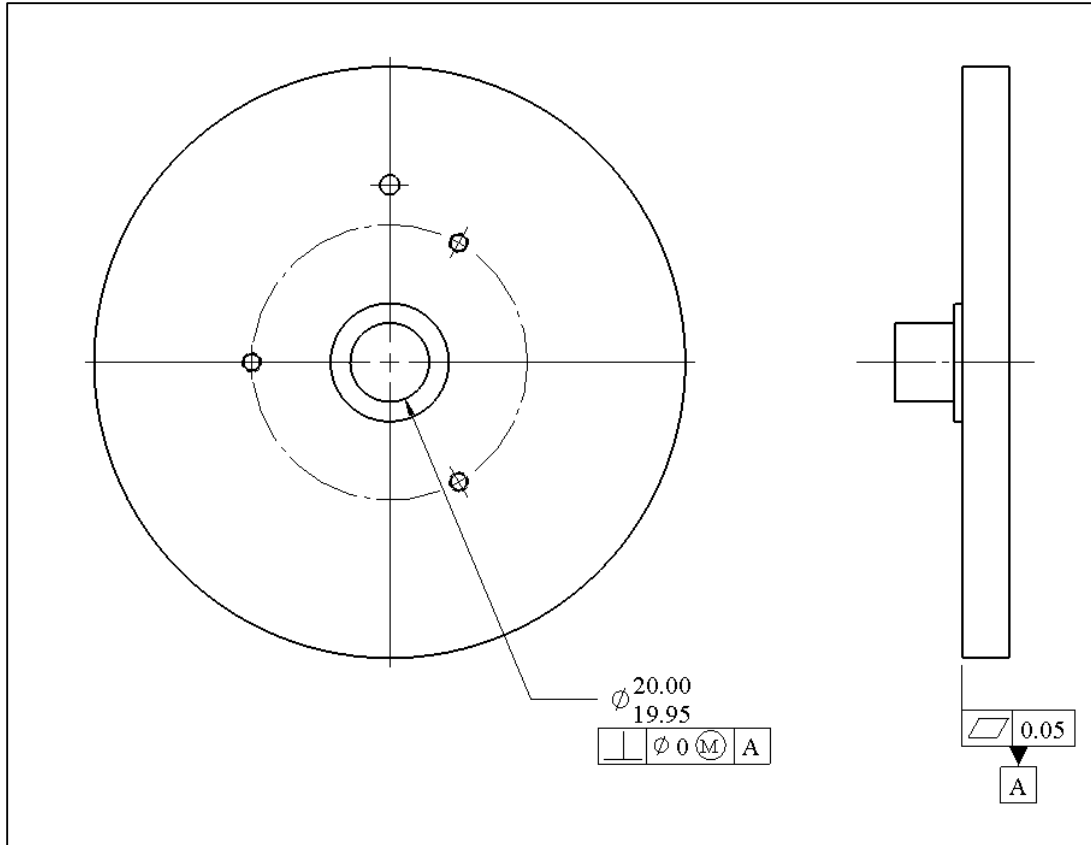
**Figure 9-18.** The base and socket are aligned using a center cylindrical fit and a dowel pin

The primary orientation between the two parts is fixed through the seating surface contact. The parts are located precisely with respect to each other through the alignment boss and hole in the center of each part. The in-plane orientation between the two parts is set by a dowel pin that is pressed into the base hole and fits the socket hole. Fixed fasteners are then used to fix the two parts together.

The nominal size of the center fit feature is 20 mm, the dowel pin is 5 mm, and the fasteners are M5. The thickness of the socket plate is 10 mm. The final processes are machining. We need to tolerance the two parts for the following requirements:

- a) The center fit between the boss and the hole must not allow a play of more than 0.1 mm.
- b) The dowel pin must fit tightly into the base with a slight interference.
- c) The play in the dowel pin fit must not exceed 0.25 mm
- d) The two parts must align sufficiently to allow M5 fasteners to fix the parts.

*Part-a)* Using the zero-geometric tolerance method, the size limits of the boss should be set to 19.95 – 20.00 mm and the size limits of the center hole should be set to 20.00 – 20.05 mm. Both features will have a zero perpendicularity tolerance at MMC specification. The primary datum is the seating surface (datum-A) and its flatness is controlled to 0.05 mm consistent with the milling process and sufficient to prevent rocking. Figure 9-19 shows the result for the base after this step.



**Figure 9-19. The base tolerances to achieve precision center boss and hole fit**

*Part-b)* The size limits of the press-fit hole receiving the dowel pin is specified to be 5H7 to fit a dowel pin of size 5p6 for a tight locational interference fit.

*Part-c)* The fit of the dowel pin to the clearance hole in the socket is a fixed fastener fit case. Using the fixed fastener formula

$$T_{Hc} + T_{Hp} \leq H_{min} - F_{max}$$

$H_{min}$  is the MMC size of the clearance hole,  $F_{max}$  is the MMC size of the dowel pin, and  $T_{Hc}$  and  $T_{Hp}$  are the position tolerances of the clearance and press-fit holes respectively. We will use the tolerances associated with precision drilling operations and then check to make sure the fit play will not exceed the stated 0.25 mm. The total size tolerance for a 5.2 mm drill is 0.05 mm. We will set the size limits of 5.20 – 5.25 mm for the hole created by this drill. Using the fixed fastener formula

$$T_{Hc} + T_{Hp} \leq H_{min} - F_{max} = 5.2 - 5 = 0.2 \text{ mm}$$

Dividing this position tolerance equally between the clearance hole and press-fit hole

$$T_{Hc} = 0.1$$

$$T_{Hp} = 0.1$$

These position tolerances are within the capability of precision drilling process. We can now check the maximum play in the dowel pin fit.

The maximum play in the dowel pin fit is

$$P_{\max} = H_{\max} - F_{\min}$$

$$P_{\max} = 5.25 - 5.0 = 0.25 \text{ mm}$$

The maximum play is equal to the required limit of 0.25 mm. We can convert the clearance hole limits to zero position format by expanding the size limits to 5.10 – 5.25 mm. Figure 9-20 shows the result for the base part with press-fit holes after setting up the dowel pin fit.

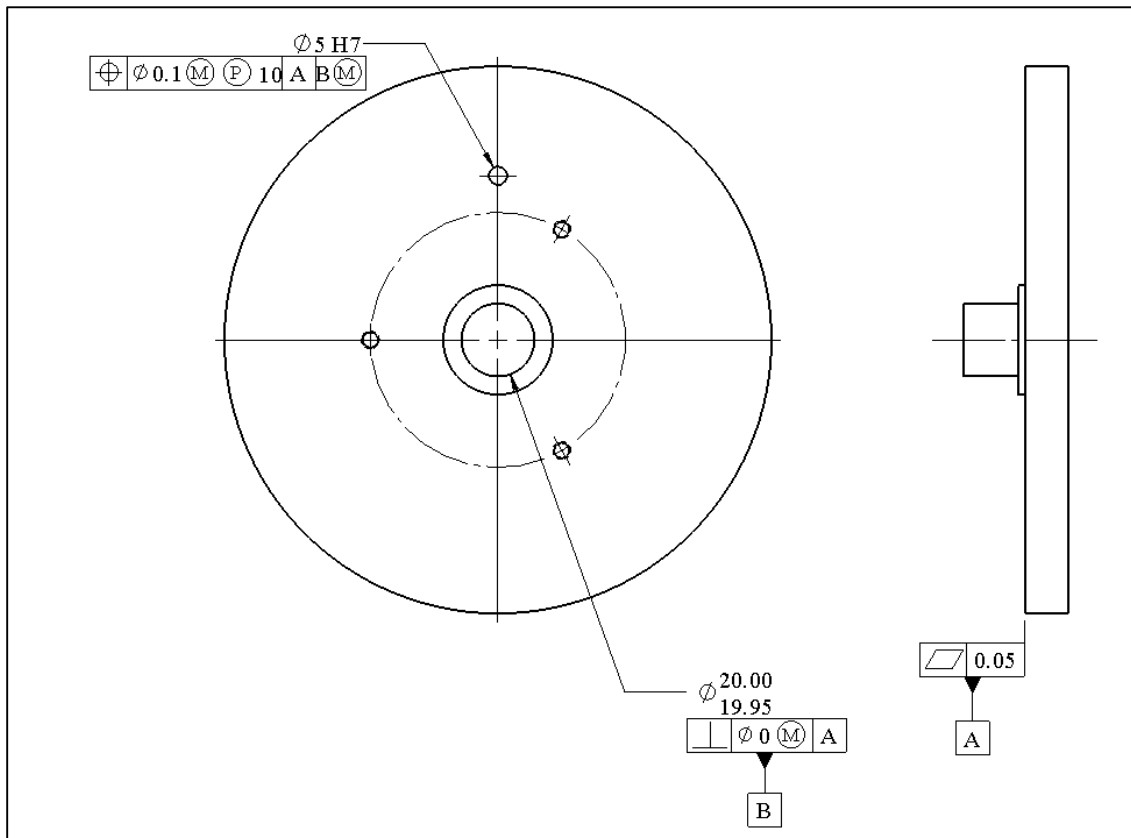


Figure 9-20. The base tolerances to achieve precision dowel pin fit

Part-d) The fastener holes for M5 screws can be created by 5.5 mm drills holding size limits of 5.50 – 5.58 mm. Using the fixed fastener formula

$$T_{Hc} + T_{Ht} = H_{\min} - F_{\max}$$

$$T_{Hc} + T_{Ht} = 5.5 - 5.0 = 0.5 \text{ mm}$$

Dividing this total position equally between the threaded and the clearance holes leads to  $T_{Hc} = T_{Ht} = 0.25$  mm. The position tolerance is directly applied to the threaded holes. With the clearance holes, we use the zero position size limits by expanding the clearance hole size tolerance by 0.25 mm on the MMC side to obtain 5.25 – 5.58 mm. The complete tolerance specifications related to the required fits are placed on the base part drawing as shown in Figure 9-21.

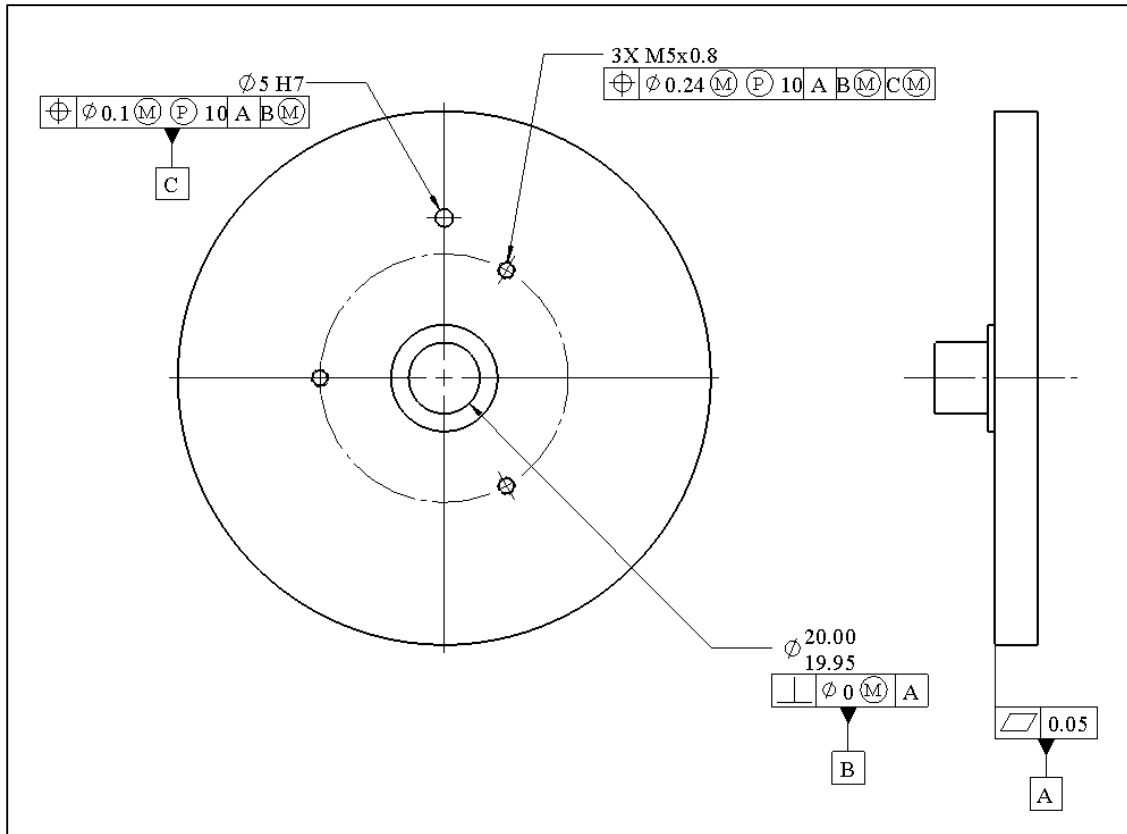


Figure 9-21. Complete size and position tolerances for the fit of all features

Note that both the dowel pin holes and threaded holes require the projected tolerance zone specification. Figure 9-22 shows the complete tolerancing of the socket part.

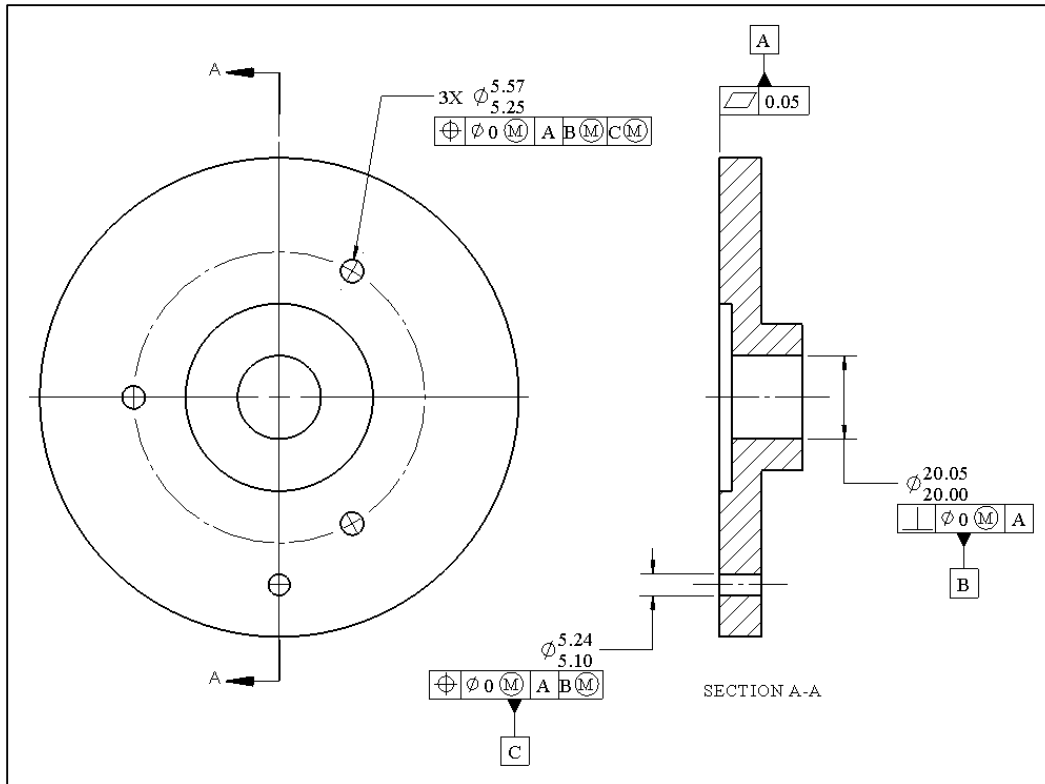


Figure 9-22. Complete tolerancing of the socket part

## 9.10. Tolerance design of press-fit inserts

The simple assembly shown in Figure 9-23 is similar to a two-part orientation-constrained fit except that one of the parts has a press-fit insert.

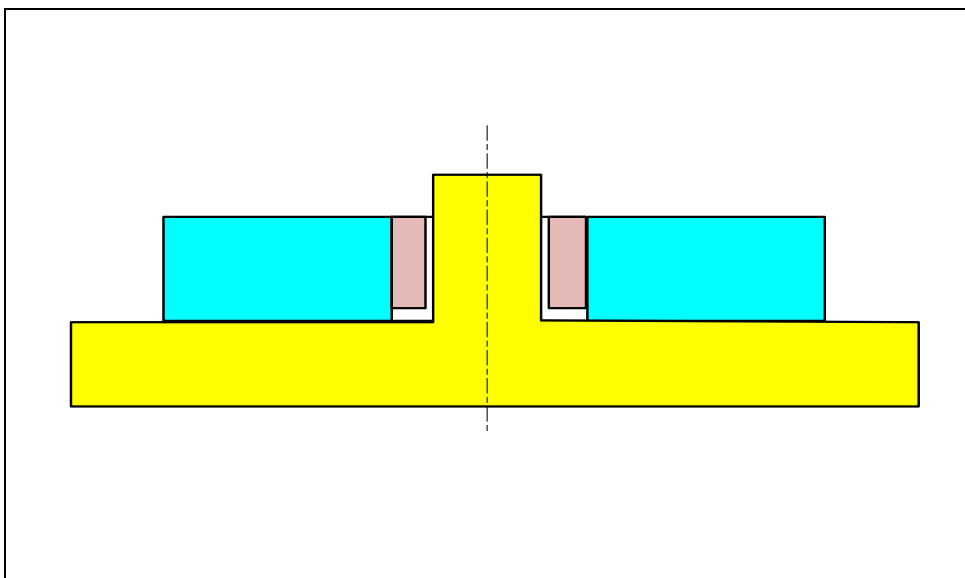
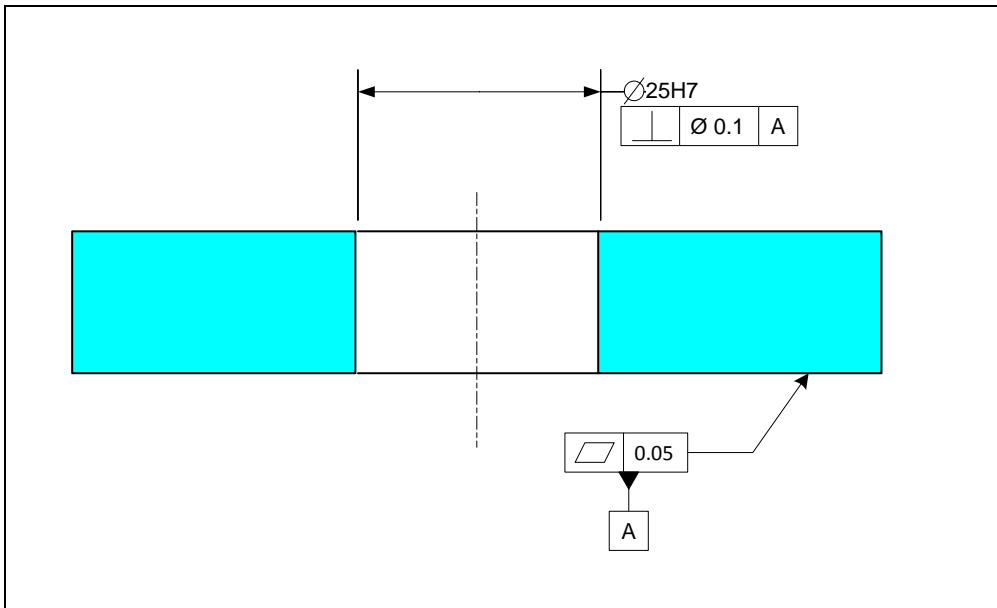


Figure 9-23. Assembly of a hole feature with a press-fit insert

The part that accepts the insert is toleranced as shown in Figure 9-24. Note that the MMC modifier cannot be used on the perpendicularity of the hole because the hole requires precise size control for press-fit application.



**Figure 9-24. The hole precision size tolerance is necessary for the press-fit insert**

The insert and the plate with the boss are toleranced in Figure 9-25. The outer diameter of the insert fits the plate hole with a light interference fit. The inner diameter must be controlled to be parallel to the outer diameter. In this simple three-part assembly, the location of the inner diameter with respect to the outer diameter is not important because the top part is loose and can center itself to line up with the boss.

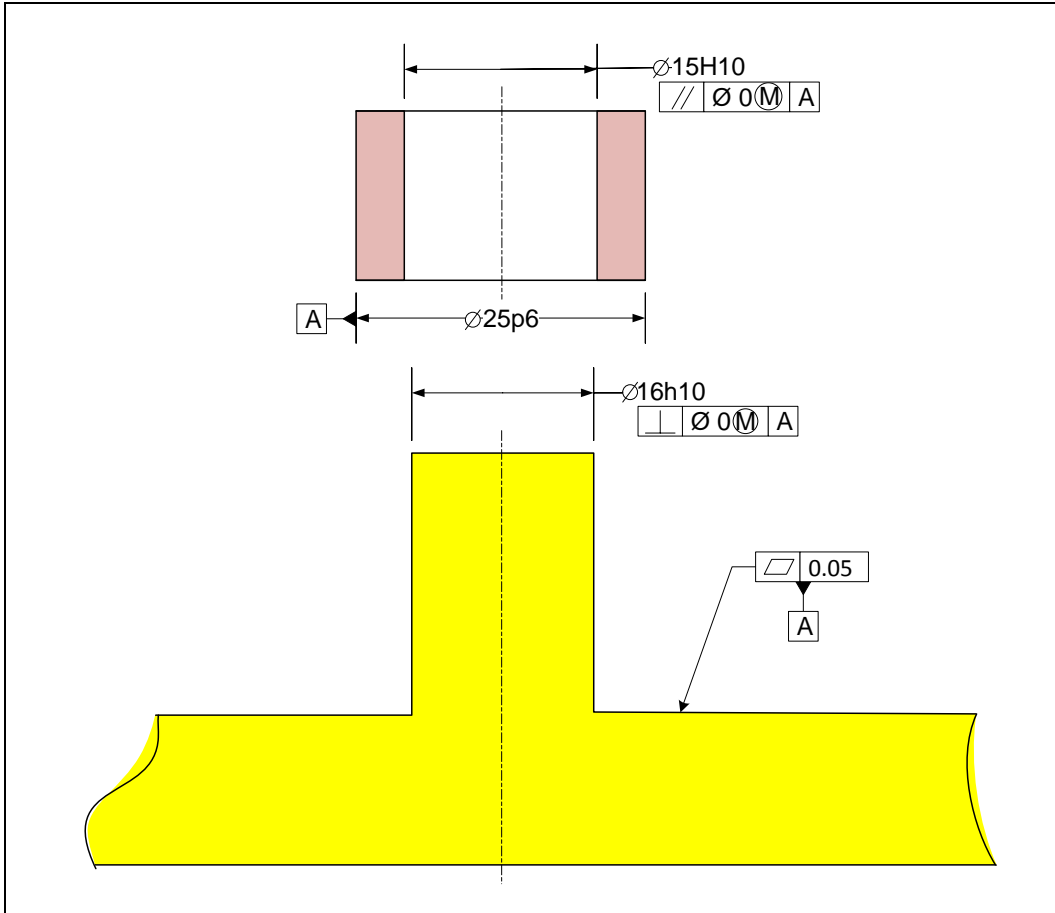
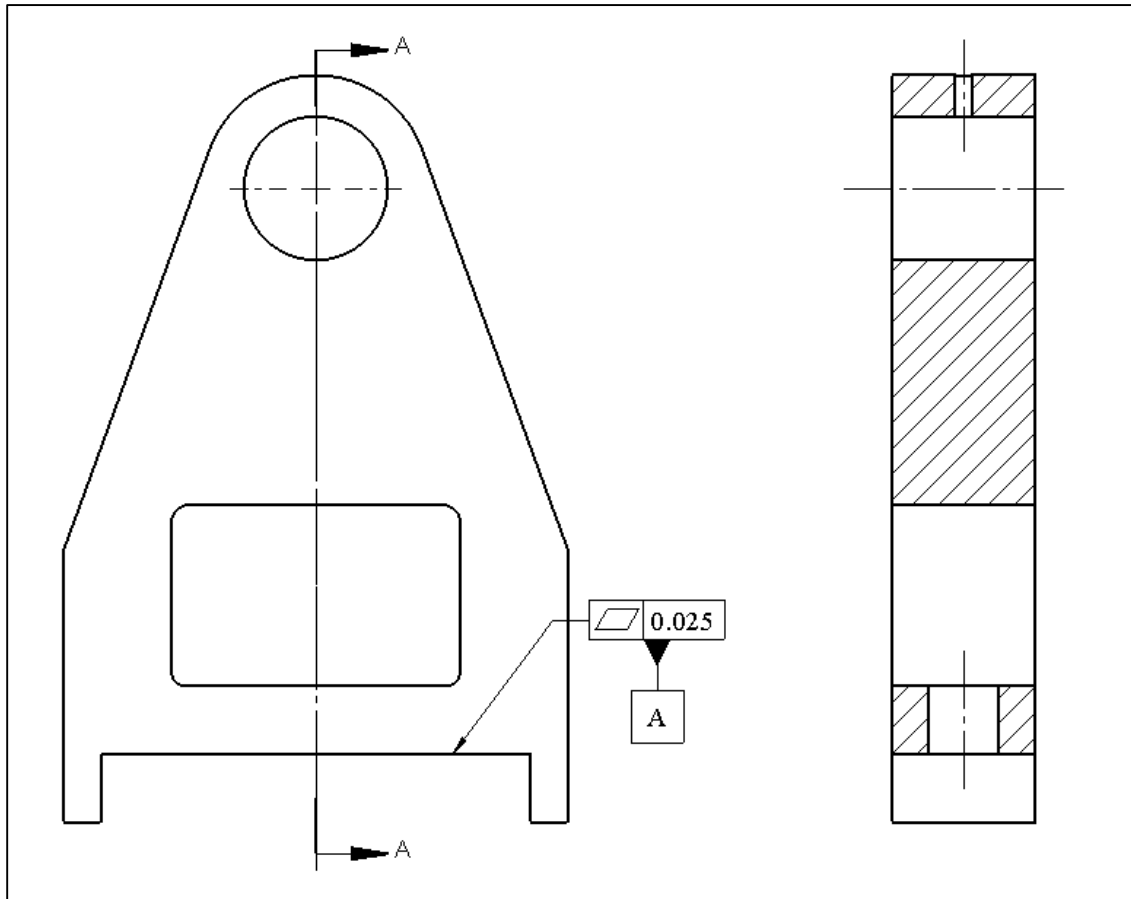


Figure 9-25. The tolerances of press-fit insert and boss features

### Exercise Problems

- Two plates with clearance holes are to be attached using a pattern of 10 mm loose bolts. Select the smallest standard drill size that will be adequate for the application. Specify hole size tolerances to be consistent with the chosen drill size. Make a reasonable estimate of economical drilling position tolerances and determine whether free assembly is assured. If free assembly is not assured, select a larger size drill and repeat the procedure. What are the final acceptable size limits and position tolerances for the holes when size and position tolerances are specified separately? What are the hole size tolerances when zero position tolerances are used. Verify the results using FAP.
- Solve Exercise Problem#1 assuming the plates are to be fastened using tapped holes and screws. What are the final acceptable size limits and position tolerances of the clearance holes and the position tolerance of the tapped holes when size and position tolerances are specified separately. What are the hole size tolerances when zero position tolerances is used. Verify the results using FAP.

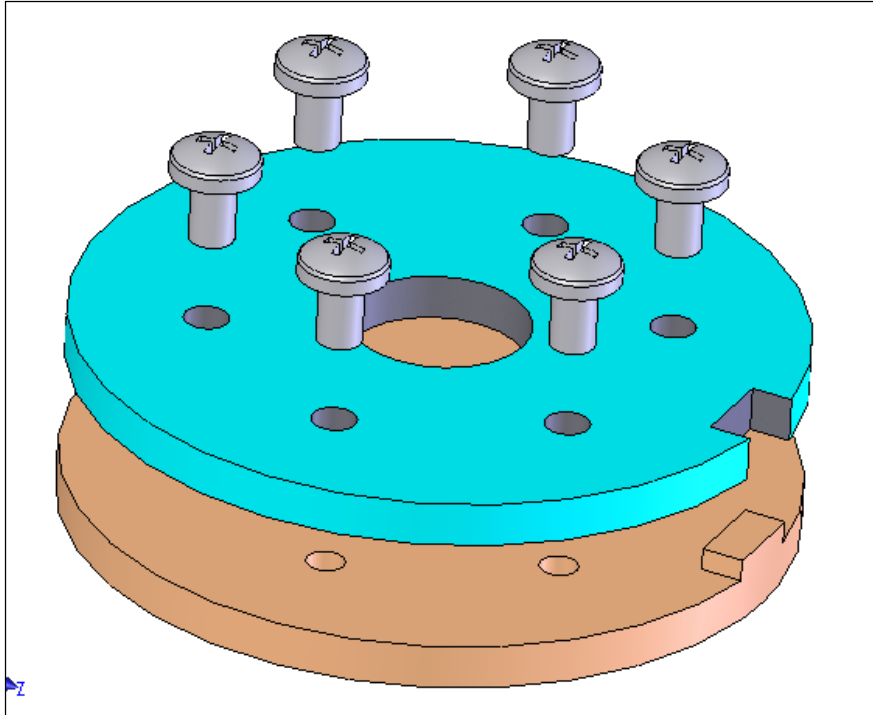
3. The slot feature of the turning support is to fit to the rail of the base and be fixed to the base using a 12 mm loose bolt. Figure 9-26 shows the turning support.



**Figure 9-26. Turning support**

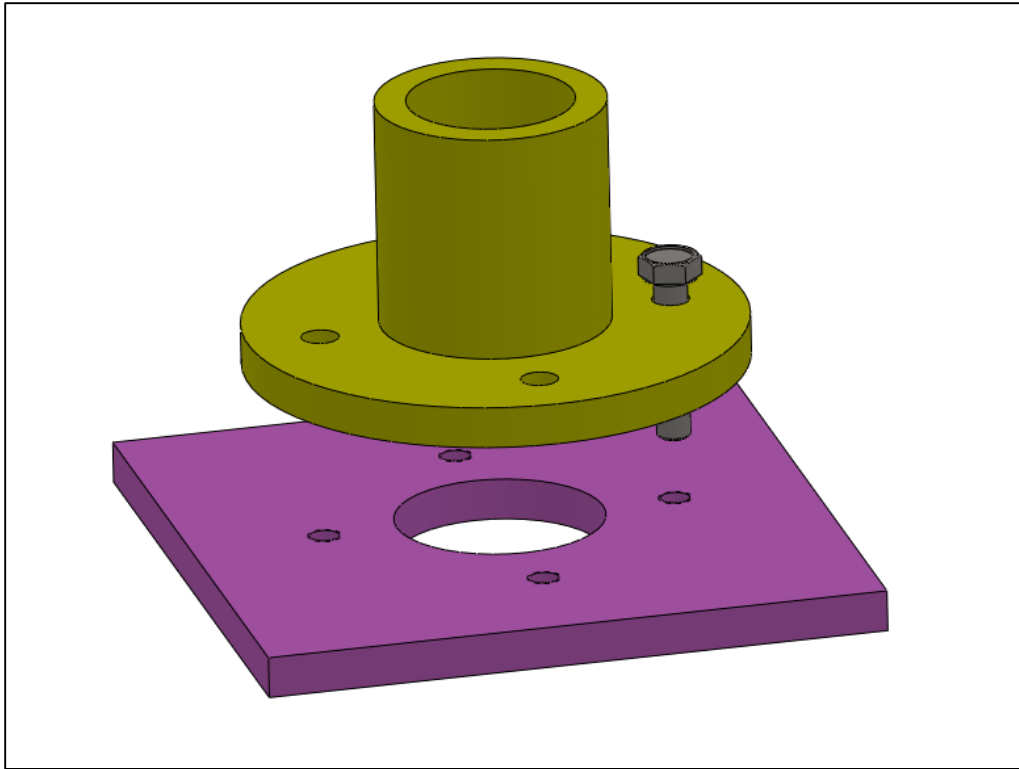
We like to create the necessary tolerance statements for the fit of the slot and rail as well as a 12 mm loose bolt. The play in the slot and rail fit should not exceed 0.1 mm. The bolt holes are to be drilled.

4. Consider a plate with six clearance holes fitting a plate with six threaded holes using 10 mm cap screws as shown in Figure 9-27. The center boss has a nominal size of 40 mm and fits a center hole on the mating part. The maximum play in the center fit is to be 0.1 mm. The clearance holes for the screws are to be created by drilling. The thickness of both plates is 8 mm. Model the assembly on a CAD system and fully tolerance the two parts for proper fit.

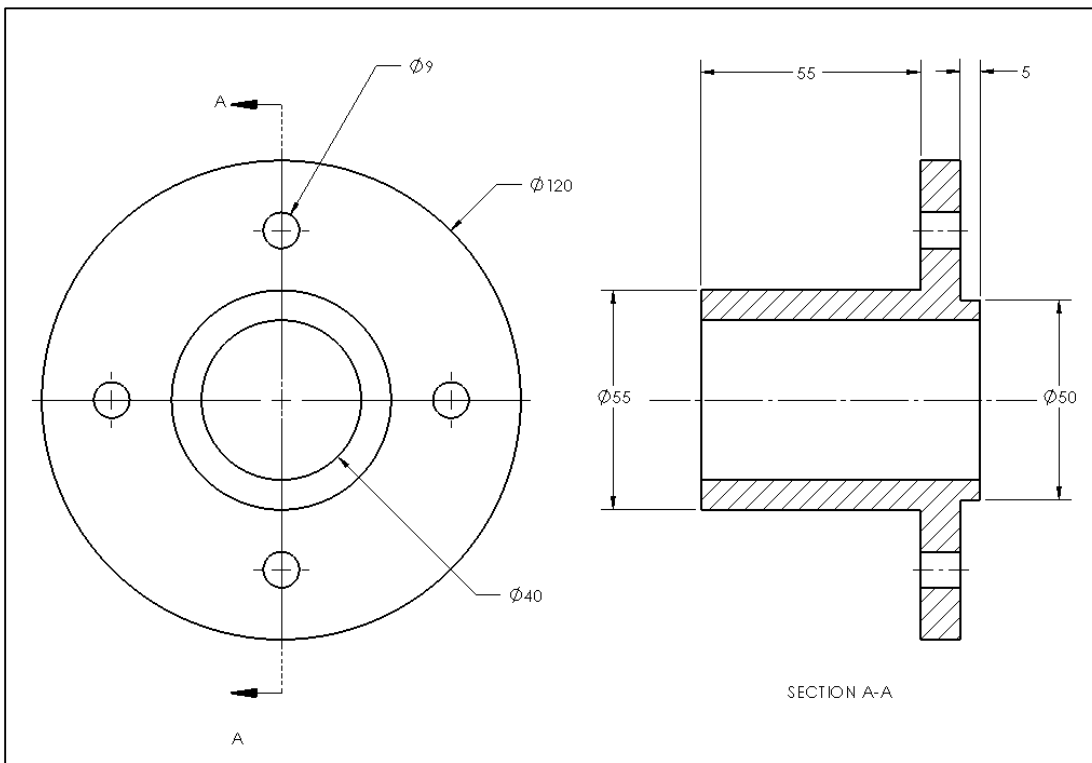


**Figure 9-27. Assembly of two plates using a pattern of cap screws**

5. Find an actual example of the assembly of two parts with floating fasteners. Take a picture and using a simple drawing indicate the specification types necessary to achieve a fit.
6. Find an actual example of the assembly of two parts with fixed fasteners. Take a picture and using a simple drawing indicate the specification types necessary to achieve a fit.
7. Consider the post-holder and base plate shown in Figure 9-28. A partially dimensioned drawing of the post holder is shown in Figure 9-29. A lip on the mounting surface of the post-holder fits tightly into the base part. The four clearance holes are to align with tapped holes in the base for M8 cap screws. Use the size limits of 50 H9 and 50d9 for the lip fit features. Both parts are to be made by machining. Create a model of this assembly along with fully dimensioned and toleranced drawings of the parts.



**Figure 9-28. Assembly of post holder and base plate using a pattern of cap screws**



**Figure 9-29. A partially dimensioned drawing of the post holder**

## Accuracy of Manufacturing Processes (MAP) Program

Estimates of drill tolerances can be obtained from the Manufacturing Accuracy Program (MAP). The dialog window shown in Figure 9-30 represents a sample input for a drill. The user selects the drill size, the depth of the drilled hole, and whether the drilling process is performed with high or regular degree of accuracy.

The screenshot shows a software dialog window titled "Accuracy of Manufacturing Processes (MAP) Program". It is divided into several sections:

- Units:** Radio buttons for "Inches" and "mm". "mm" is selected.
- Precision Level:** Radio buttons for "High Precision" and "Regular Precision". "Regular Precision" is selected.
- Feature Type:** Radio buttons for "Flat Surface", "Cylindrical", "Width (Parallel-Planes)", and "Profile". "Cylindrical" is selected.
- Process Selection:** A tabbed interface with "Milling", "Drilling/Reaming", "Turning/Boring/Grinding", and "FDM". "Drilling/Reaming" is selected. Inside this tab, there are radio buttons for "Drilling" and "Reaming". "Drilling" is selected.
- Tolerance Type:** A dropdown menu with "Size" selected.
- Feature Parameters:** A green box containing three input fields: "Size" (11), "Depth" (10), and "Position" (30).
- Result:** A pink box containing a "Tolerance Value" field showing "+/- 0.046" and a "Calculate" button.

Figure 9-30. The size accuracy of the drilling process

In this case, the user has selected to estimate the size tolerance for a 11 mm drill and the answer is in the  $\pm$  format. The total size tolerance is about 0.09 mm. The position tolerance for this drilled hole is shown in Figure 9-31.

The image shows a software interface for calculating the position accuracy of the drilling process. The interface is organized into several sections:

- Units:** Radio buttons for  Inches and  mm.
- Precision Level:** Radio buttons for  High Precision and  Regular Precision.
- Feature Type:** Radio buttons for  Flat Surface,  Cylindrical,  Width (Parallel-Planes), and  Profile.
- INT/EXT:** Radio buttons for  INT and  EXT.
- Process Selection:** A tabbed interface with 'Milling', 'Drilling/Reaming', 'Turning/Boring/Grinding', and 'FDM'. 'Drilling/Reaming' is selected.
- Tolerance Type:** A dropdown menu showing 'Position'.
- Process:** Radio buttons for  Drilling and  Reaming.
- Feature Parameters:** Input fields for Size (11), Depth (10), and Position (30).
- Result:** A 'Tolerance Value' field displaying '0.129' and a 'Calculate' button.

Figure 9-31. The position accuracy of the drilling process

# Chapter 10

## Tolerance Design of Multipart Fits

### 10.1. Overview

In the previous chapters we discussed the tolerance design and tolerance analysis for fits involving two parts. Simple formulas were developed to assure fit between two directly fitting parts using the concept of fit boundaries. We also looked at the case of two parts fixed together by fasteners.

In multipart fits, a fit is influenced by the dimensions and tolerances of more than two parts. The collection of part dimensions often forms a loop with each part connecting to two other parts in the loop. Fit ability becomes the result of how the tolerances accumulate or stack up in the worst case situations. For that reason, tolerance analysis is sometimes called stack analysis. If the tolerances accumulate to a value greater than the clearance allocated by the design, the parts may not fit together. Design engineers often try to avoid precision fits that depend on more than two parts. When that is unavoidable, designers try to minimize the number of parts and features that influence a precision fit. Obviously, the more the number of tolerance values that influence a fit, the smaller each tolerance value needs to be to achieve that precision fit.

The rules and preferences for tolerance design (synthesis) are intuitive but do require practice. Tolerance analysis procedure for multipart fits is more mathematical. For that reason, tolerance design and tolerance analysis are presented in separate chapters. Tolerance design is the more important step and requires the selection of best tolerance types. This chapter presents the preferred practices for tolerance design of multipart fits.

Tolerance design for fit requires a designer to first recognize the parts, features, and geometric deviations that influence a fit. Subsequently proper types of tolerances should be applied in a manner similar to what was done for two-part fits. Initial tolerance values should be selected based on processes that the designer believes would produce the required precisions. An estimate of these tolerance values can be obtained using the Manufacturing Accuracy Program (MAP). The initial dimension and tolerance values applied to parts may not assure fit or may not be the best choices. Tolerance analysis, which follows tolerance design, will allow a designer to adjust the initial dimensions and tolerance values to achieve the desired fit performance. The fit performance refers to the minimum and maximum possible values of a critical gap or dimension.

This chapter presents the tolerance design methodology and preferred practices using a variety of example problems. It is important to study all of these examples because they cover many kinds of assemblies. Most of the examples are set up as simple geometric constructions rather than real machine assemblies. This is done intentionally to focus on specific concepts and to reduce distractions.

## 10.2. Application of profile tolerances

**Example-1: A simple tolerance design problem:** A simple assembly is shown in Figure 10-1. Assume the parts are three dimensional and have depth. The gap between the end surfaces of part<sub>2</sub> and part<sub>3</sub> is a critical assembly dimension and must not become negative. None of the dimensions of part<sub>1</sub> influence the gap. The flatness of the top surface of part<sub>1</sub> is the only important geometric aspect of part<sub>1</sub> influencing the gap. The figure shows the dimensions influencing the gap as vectors. Each vector belongs to a single part except for the gap vector that jumps across the gap between two parts. We will see the use of vectors for mathematically representing dimensions and tolerances in Chapter-11 on tolerance analysis.

The vectors establish a theoretically common orientation along which the distances influence the gap. Some tolerance statements control the size of the vectors along the common orienting direction while other tolerances control the direction of some vectors to closely align with the common orienting direction. The common orienting direction is determined by the surfaces that orient the parts with respect to the assembly. In the case of this simple problem the common direction is perpendicular to the top surface of part<sub>1</sub>.

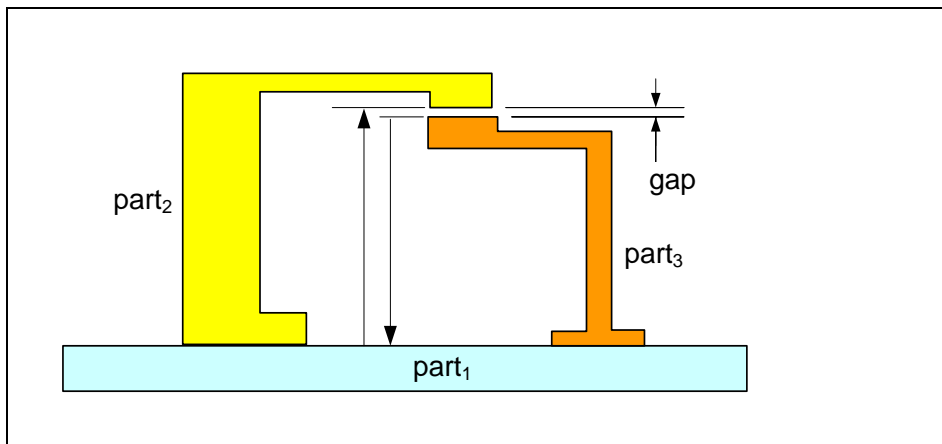
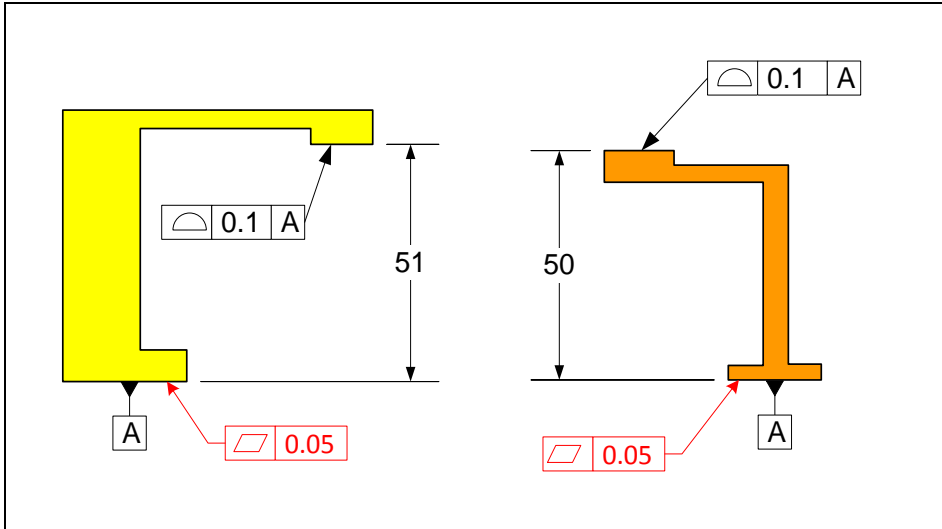


Figure 10-1. An example of a fit involving two dimension values

For this problem, the gap is influenced by one dimension on each part. Figure 10-2 shows how the relevant features are initially toleranced to control the critical gap. In this case, profile tolerances are used for dimension control. Datum control statements are shown in red while the dimensions that directly influence the gap are shown in black.

Tolerance values are to be selected based on the processes believed to have sufficient precision to meet the requirements. Theoretical dimensions and sizes are initially selected to allow a small gap. The tolerance analysis procedure, which will be presented in Chapter-11, will adjust the initial theoretical dimensions and, if necessary, the tolerance values such that the gap requirements are met.



**Figure 10-2. Profile tolerances control the fit gap in the example**

In tolerancing multipart fits it is helpful to define a *presumed order of assembly*. The presumed order of assembly is just an organizational tool to make tolerancing practice easier and more uniform among designers. The presumed order of assembly need not match the actual order of assembly for the tolerancing to be correct. The part numbers in these examples identify the presumed order of assembly.

In this chapter we will use convenient tolerance values but in real assemblies realistic tolerance values must be used. Datum precision tolerances, i.e. the flatness statements, are shown in red while direct fit-related tolerances are shown in black.

Many fit applications involve the geometric accuracy of more than two parts. These fits are referred to as multipart fits. The following example is a multipart fit that needs mainly profile tolerance specifications.

**Example-2: A simple four-part tolerance design problem:** Figure 10-3 shows a simple four-part assembly in which all four parts influence the gap value. The gaps as well as the vectors representing various dimensions are also shown.

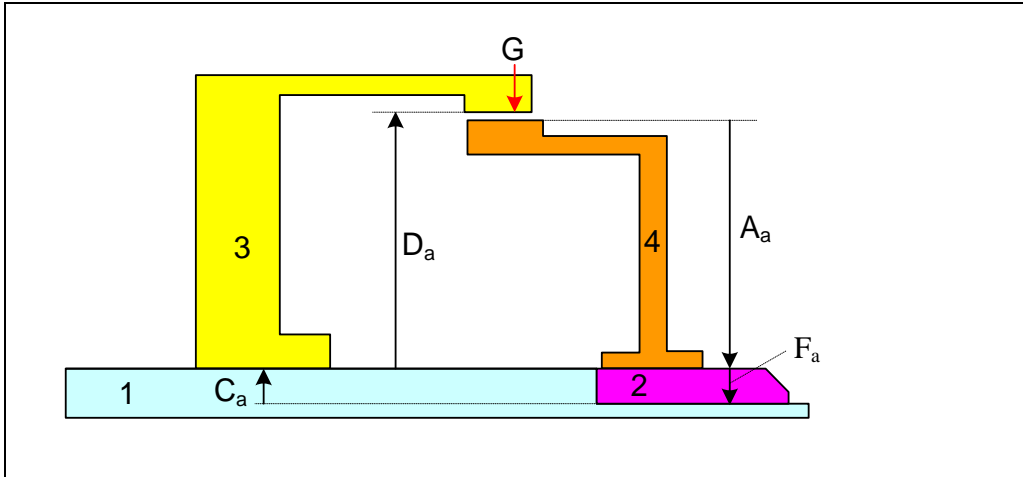


Figure 10-3. An example of a fit involving four parts

The tolerancing of part<sub>1</sub> is shown in Figure 10-4. Only the tolerance statements relevant to the gap control are shown. Datum-A orients the part with respect to the rest of the assembly. We can also select the top surface as the part orienting datum. Given two equally valid options we use the presumed order of assembly to make the selection. In this case, the lower surface contacts part<sub>1</sub> first according to the presumed order of assembly.

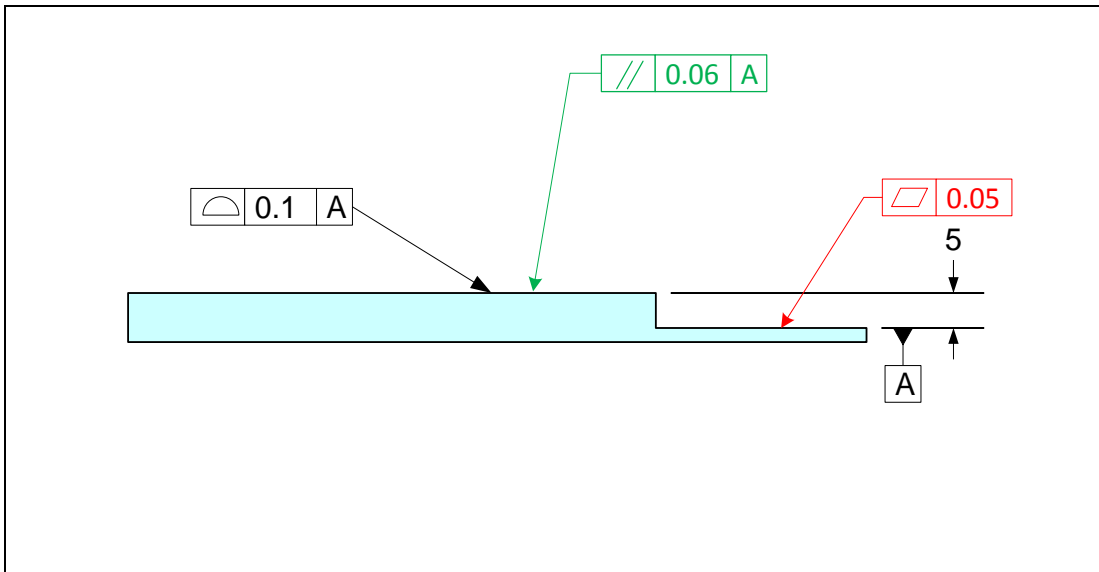
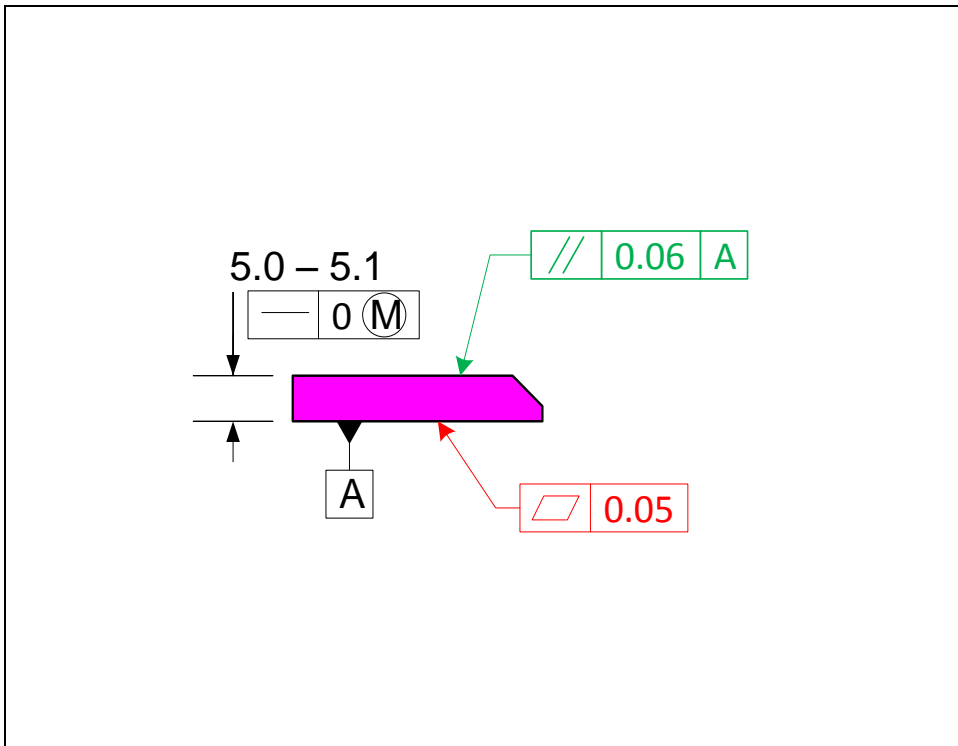


Figure 10-4. Tolerancing of part<sub>1</sub> in the example assembly

The top surface controls the orientation of part<sub>3</sub> or vector  $D_a$ . The parallelism specification is necessary to minimize the angular deviation of this vector from the common orientation direction. The parallelism statement minimizes the distortion angle between part<sub>2</sub> and part<sub>3</sub>. Distortion control specifications are shown in green. The profile

specification controls a dimension that directly influences the main fit. The reference to datum-A in the profile statement indicates that measurements must be made along the common orienting direction. The tolerancing of part<sub>2</sub> is shown in Figure 10-5.



**Figure 10-5. Tolerancing of part<sub>2</sub> in the example assembly**

Datum-A establishes the orientation of this part with respect to the assembly. The top surface can also be chosen as the orienting datum but the selected datum-A occurs first according to the presumed order of assembly. The height of the plate influences the main gap directly and is controlled by size limits. This dimension can also be controlled by a profile tolerance but size limits are preferred. The parallelness specification is necessary to minimize the angular deviation of vector  $A_a$  from the common direction. The parallelness specification minimizes the angular distortion between part<sub>1</sub> and part<sub>4</sub>. The tolerance specification of part<sub>3</sub> is shown in Figure 10-6. Datum-A is the primary orienting surface for this part.

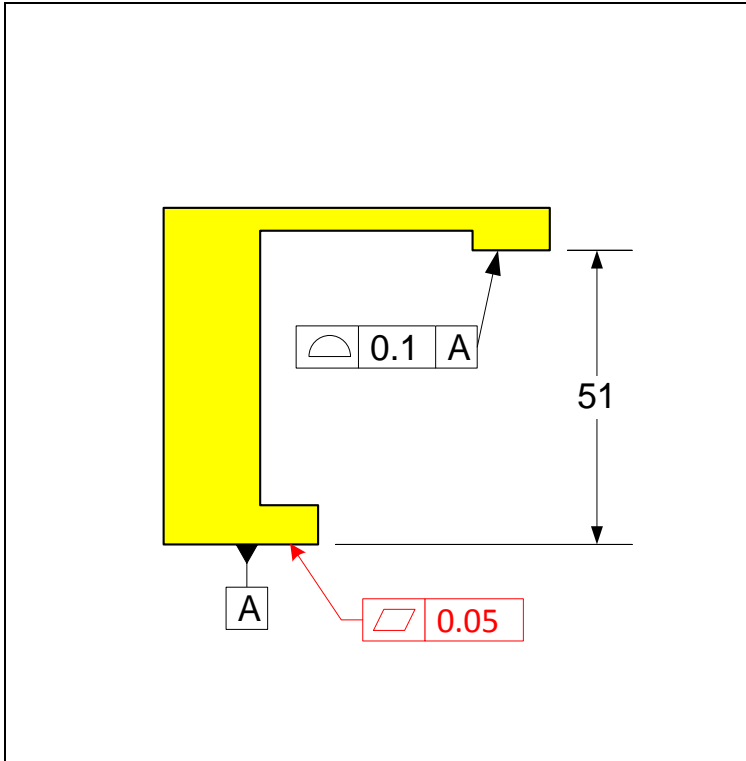


Figure 10-6. Tolerancing of part<sub>3</sub> in the example assembly

The tolerancing of part<sub>4</sub> is shown in Figure 10-7.

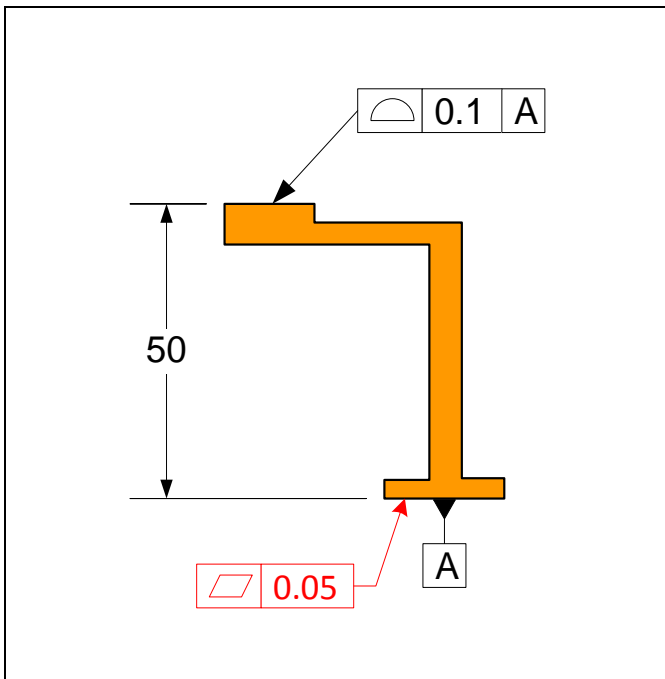
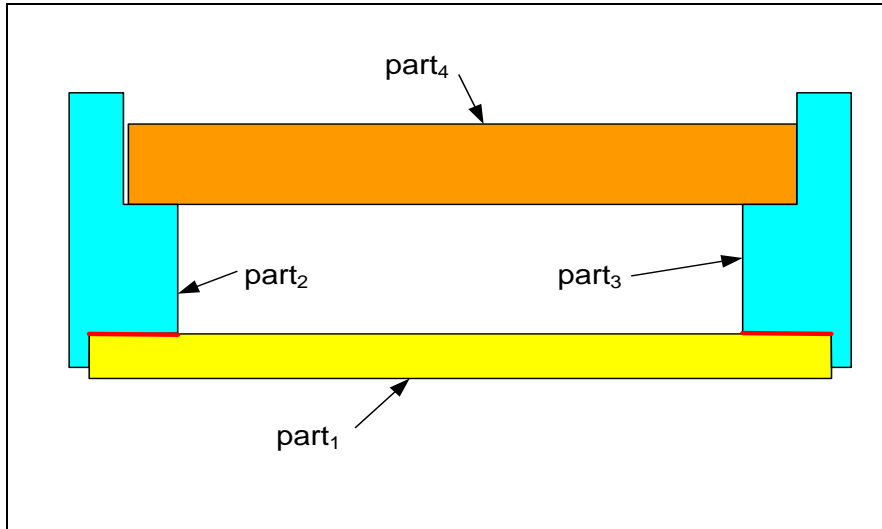


Figure 10-7. Tolerancing of part<sub>4</sub> in the example assembly

### 10.3. Fits involving features-of-size

**Example-3: A simple four-part fit:** Consider the assembly shown in Figure 10-8. To simplify the parts, assume that part<sub>2</sub> and part<sub>3</sub> are glued to part<sub>1</sub>.



**Figure 10-8.** A four-part assembly with two fit features

The glued surfaces are indicated in the figure in thick red lines and define the primary orienting direction. Part<sub>4</sub> is expected to slide in and fit through the opening and rest on the two surfaces that form a ledge. The tolerance design for the four parts is shown in Figure 10-9.

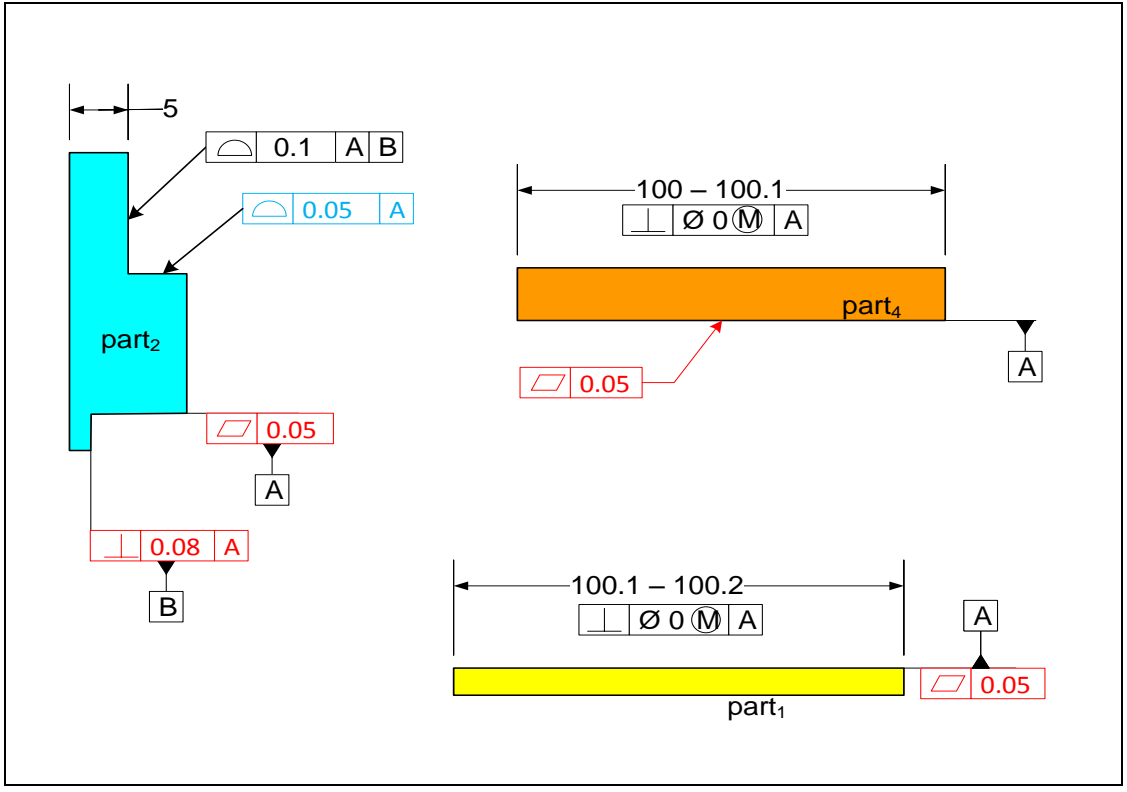


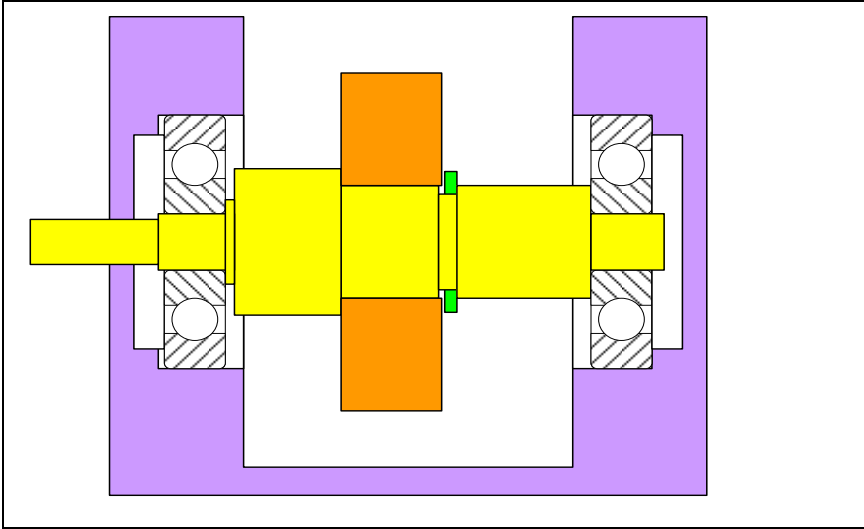
Figure 10-9. The initial assignment of dimensions and tolerances

Part<sub>1</sub> contacts part<sub>2</sub> and part<sub>3</sub> on the same surface. This surface is selected as datum-A on part<sub>1</sub> and its flatness is controlled. The datum-A surface is the primary orienting feature for this part. The width dimension is the dimension that directly influences the gap.

The primary orienting surface for part<sub>2</sub> is datum-A. The profile tolerance with tolerance value of 0.1 mm controls the dimension that directly influences the gap. Note the use of the primary orienting datum in the profile statement. The profile tolerance with 0.05 tolerance value is specified to align the two seating surfaces and create a horizontal support surface for part<sub>4</sub>. This precision is necessary to create a stable contact and is a function-related specification. Function-related specifications are shown in blue.

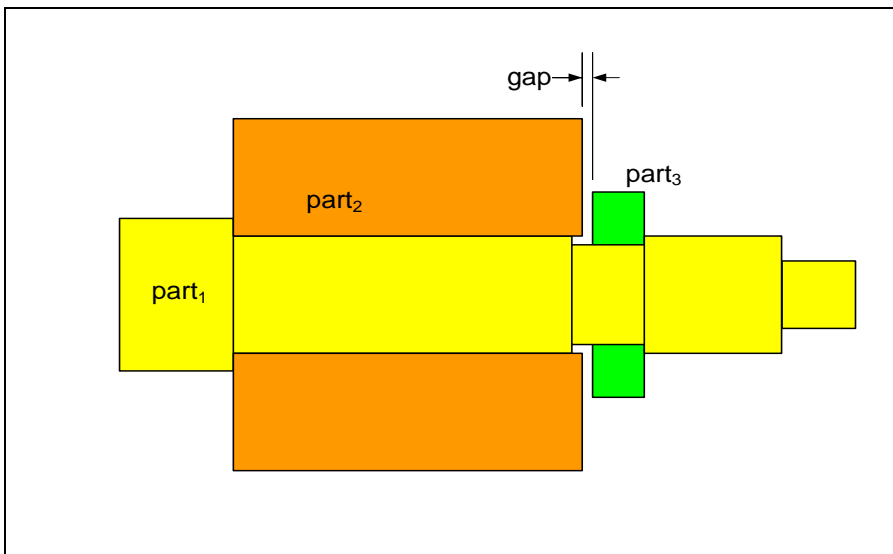
The primary orienting surface for part<sub>4</sub> is datum-A. The width dimension of this part directly influences the gap.

**Example-4: Retaining ring fit on a gearbox shaft:** One of the main applications of tolerancing is in the axial placement of power transmission components on shafts. One of the simplest examples of fit involving three parts is a gear that is axially constrained by a shaft shoulder on one side and a retaining ring on the other as shown in Figure 10-10.



**Figure 10-10.** A gearbox shaft with a retaining ring fixing the axial location of the gear

The gear and the retaining ring are purchased parts. We need to determine the specifications for the shaft groove size and its location for the retaining ring to fit the space between the groove and the gear. In addition, the ring must limit the gear play to a specified maximum value. Figure 10-11 shows a larger view of the relevant features.



**Figure 10-11.** The retaining ring limits the axial play of the gear

The gap of interest is the distance between the gear face and the retaining ring face. The initial dimensions and tolerances that control the gap are shown in Figure 10-12. The dimensions and tolerances for the gear and the retaining ring are provided by the manufacturer. The retaining ring groove size is selected to be slightly larger than the ring with a size range of 1.04 - 1.14 mm. The groove center plane location is not directly

controlled by a position tolerance. Instead, a profile tolerance is used to directly control the functional right edge of the groove.

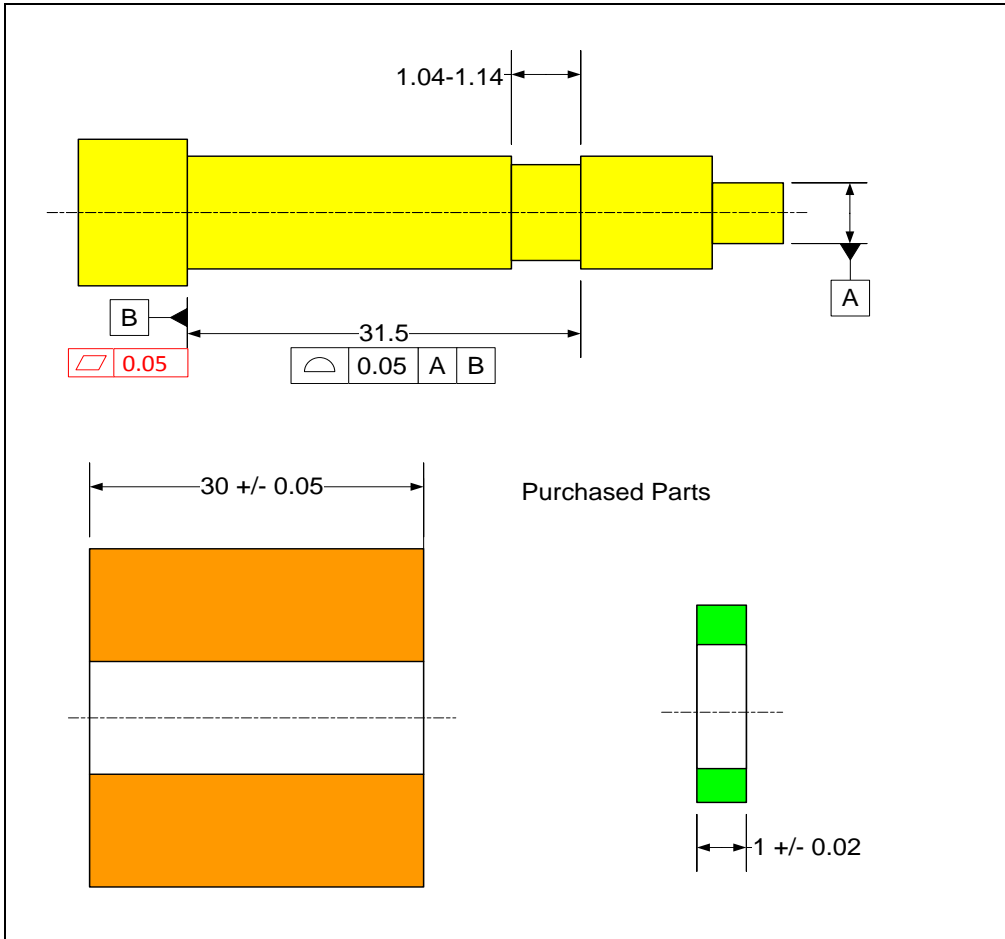


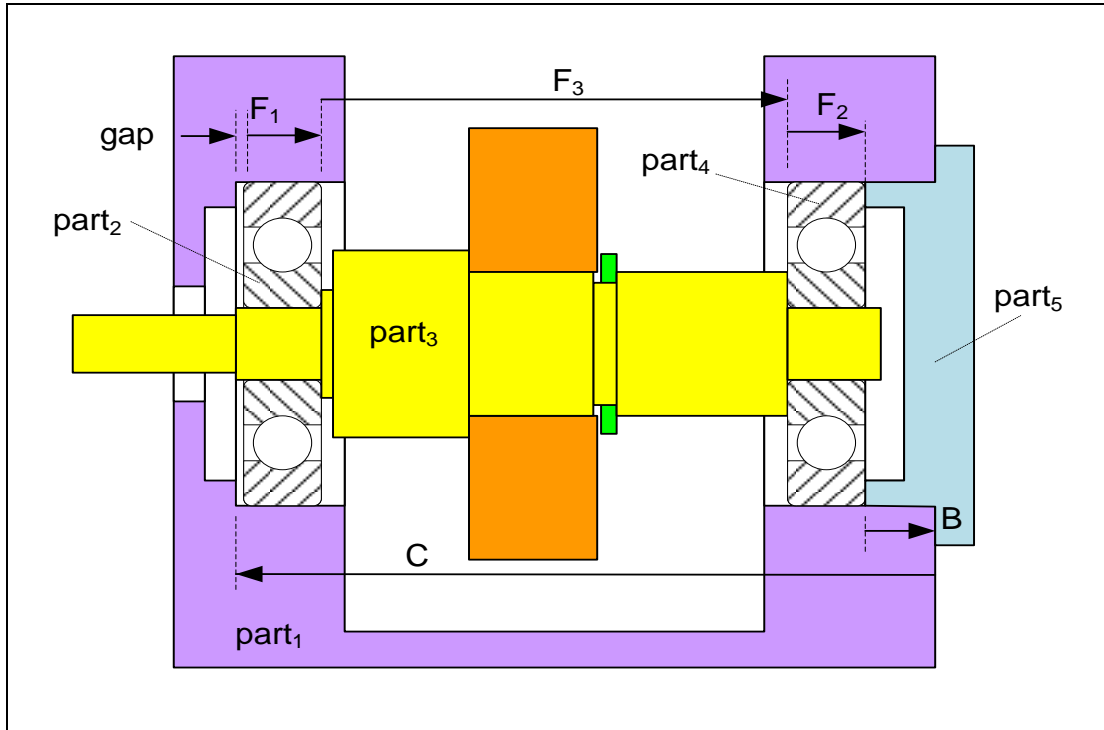
Figure 10-12. The initial assignment of dimensions and tolerances

Usually slots and grooves are controlled by size and position but this is a special situation in which only the right edge of the slot plays a precision role. For that reason, only the right edge is controlled with precision using a profile tolerance.

What feature primarily orients the shaft with respect to the assembly? For a shaft with bearing fits at the two ends, the orienting features are always the bearing fit surfaces. In Figure 10-12 only one bearing fit is shown and that bearing fit surface is selected as the primary orienting datum. The profile statement requires that the measurements be made from the shoulder (datum-B) in the direction defined by the bearing fit (datum-A).

**Example-5: Thermal expansion gap of a gearbox shaft:** Figure 10-13 shows the gearbox shaft assembly that was shown before. The figure also shows the dimensions that influence the gap identified in the figure. The gap between the housing and the bearing outer face on the left side bearing is a critical dimension that determines the axial free play of the shaft. This axial free play accommodates the thermal expansion of the

shaft and reduces the precision requirements of the shoulder-to-shoulder distance. If the gap is too small, the bearings may get axially loaded when the shaft heats up, or when the shaft is not made with high precision. If the gap is too big the gears may not align precisely enough due to excessive axial misalignment.



**Figure 10-13. The gap dimension in this gearbox depend on six part dimensions**

Figure 10-14 shows the initial assignment of tolerances that control the gap dimension. The theoretical dimensions, which are not shown, can be set up to create a small initial gap. Tolerance analysis can then adjust the selected initial values to obtain the required gap range. The primary orienting datum for the shaft is defined by the two bearing fit surfaces.

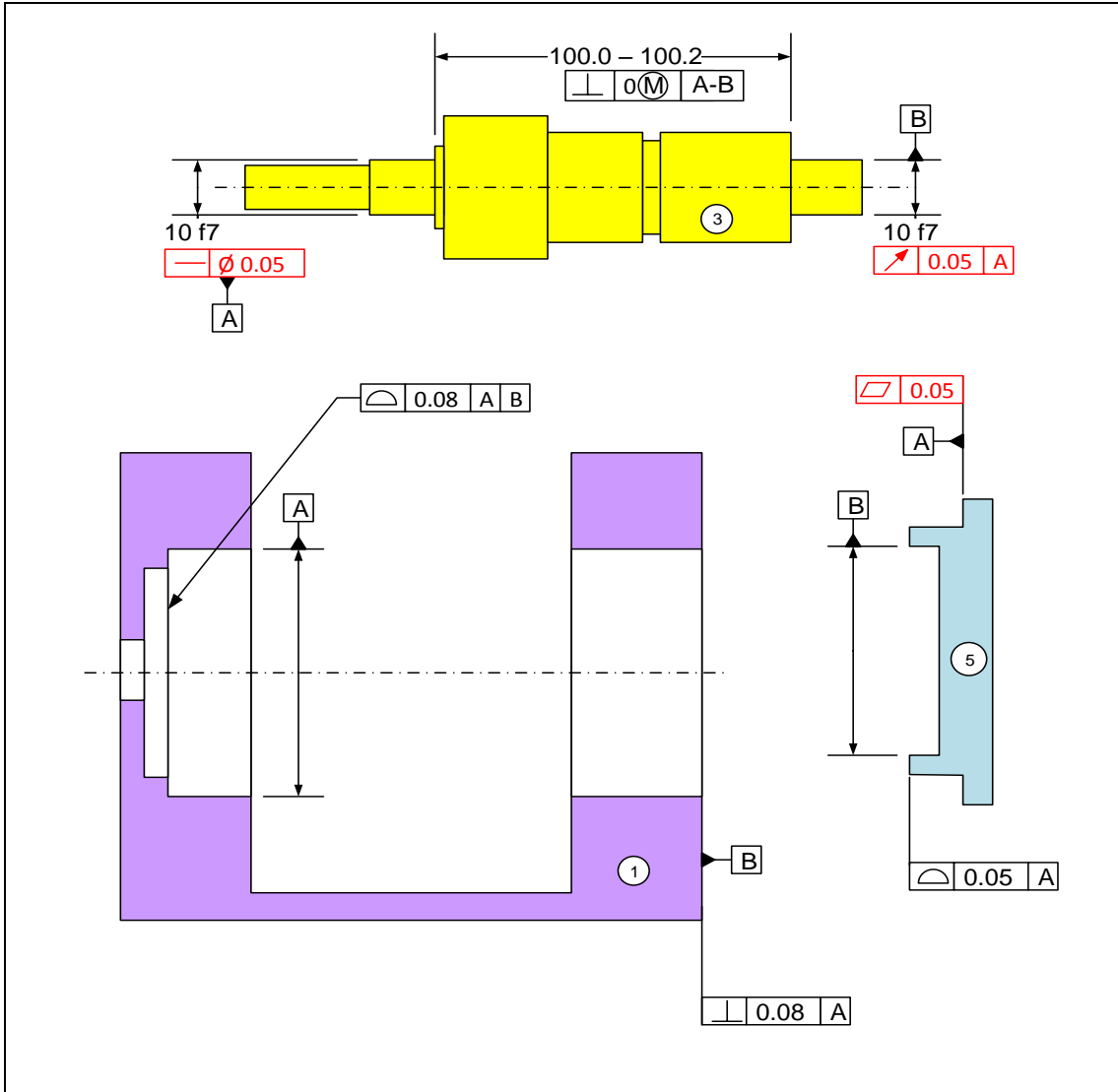
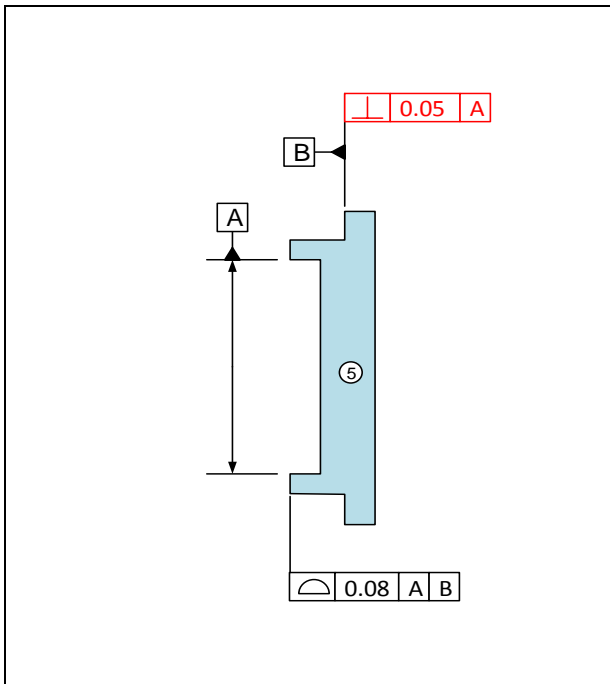


Figure 10-14. The initial assignment of tolerances

The pair of functional shoulders of the shaft is considered to be a feature-of-size and its size is controlled by direct dimension limits. Note that the perpendicularity tolerance allows a maximum of 0.2 mm tilt with respect to the axis of rotation when the distance between the shoulders is at the LMC limit of 100 mm. This amount of tilt may be objectionable as the shoulders control the alignment of the bearing races. We can keep the specifications for fit and function separate and add a new circular runout statement to keep the bearing support shoulders perpendicular to the axis of rotation (datum-A) with higher precision than 0.2 mm.

The orienting feature of part<sub>5</sub> is the shoulder designated as datum-A. If the fit of the cylindrical surface is tight, the cylindrical surface (datum-B) can be selected as the primary orienting feature. In some situations it is not clear which surface will be the primary orienting feature. In such cases the designer would select one of the features as

the primary orienting feature but adds tolerance statements that create a precision relationship between the two surfaces. Figure 10-15 shows how the tolerancing would change if we pick the cylindrical fit surface (axis) as the primary orienting datum.



**Figure 10-15. Tolerancing of parts if the cylindrical surface is selected as the primary orienting datum**

The profile statement requires the measurements to be from datum-B in the direction of the datum-A axis.

The primary orienting feature of part<sub>1</sub> is the bearing fit surfaces designated as datum-A. The datum-B must also be controlled to be perpendicular to datum-A with high precision. This is achieved by a perpendicularity tolerance.

### **Example-6: A multipart tolerance design with loose fit features**

Figure 10-16 shows a three-part assembly. The main gap is influenced by the play in the loose slot and rail fit. The slot and rail fit may also be a hole and boss fit. We would like to set up the dimensions and tolerances to assure a minimum main gap of zero.

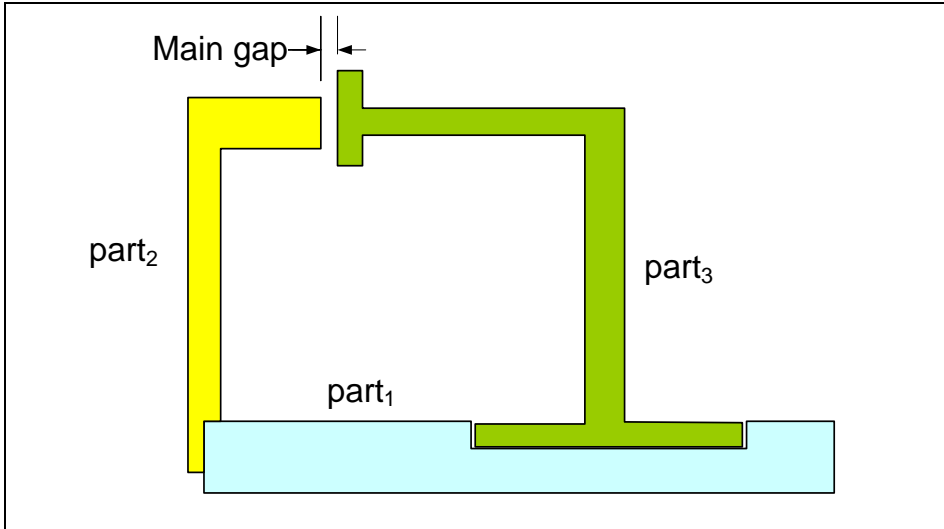


Figure 10-16. A multipart assembly with loose fit features

We start with the tolerance requirements of part<sub>1</sub>. There are two objectives in tolerancing the slot in part<sub>1</sub>. First, the slot has an orientation-constrained fit to the rail of part<sub>3</sub>. Figure 10-17 shows the tolerance statements necessary to meet this first objective. Based on this specification, the largest slot can be 20.1 mm wide. The figure also shows a 30 mm theoretical distance of the slot center plane with respect to the left edge.

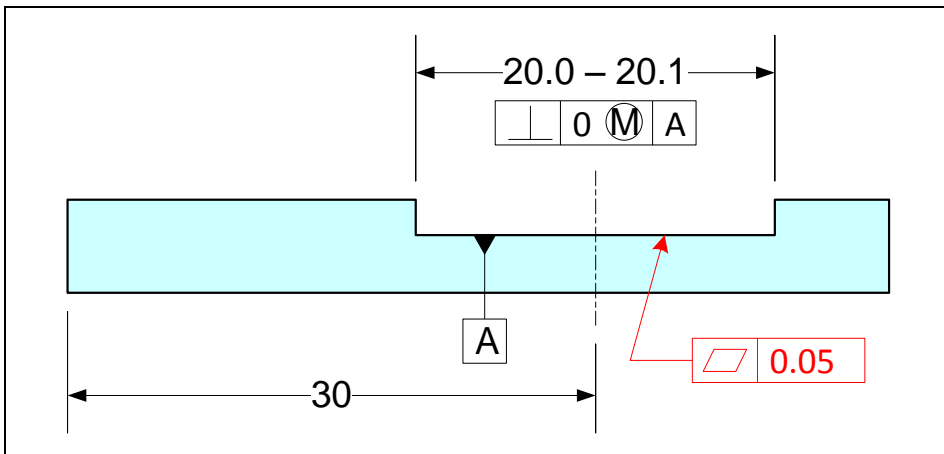


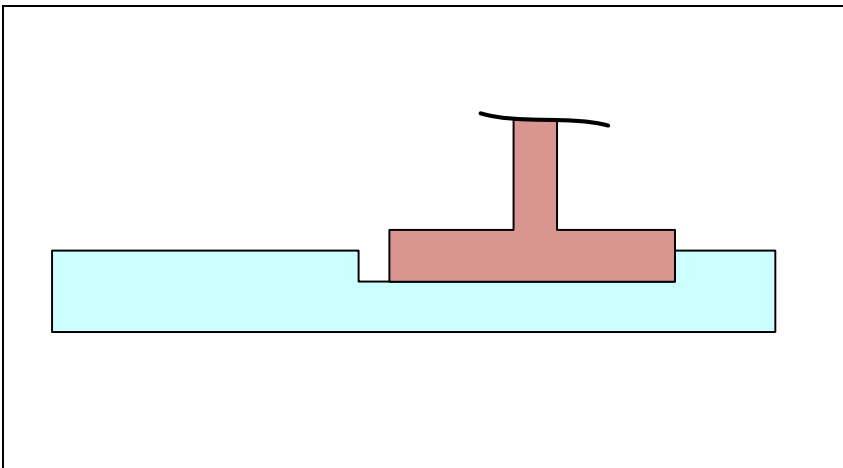
Figure 10-17. Tolerancing of part<sub>1</sub> for direct fit to rail

The second objective in tolerancing the slot is to limit the slot influence on the main gap. As a general rule, whenever a loose fit feature, such a slot and rail fit, is in the path of the main gap and the loose fit can be adjusted to a favorable arrangement during assembly, the position tolerance is best to be qualified with an  $\textcircled{M}$  modifier. We have seen many examples for two-part fits that use the  $\textcircled{M}$  modifier because in two-part fits we can always find the most favorable arrangement for one part snapping into another. To further explain this rule, when the slot is at its MMC limit of size (smallest slot) we have

minimum amount of slack to take advantage of during assembly and therefore we would like to limit the feature center plane deviation at MMC. If the slot is made to be larger than its MMC limit of size, we can allow more position deviation because the larger slack allows us to compensate for its additional deviation during assembly. Sometimes designers intentionally design large slacks in some fits when it is possible to exploit the slack at assembly time.

When the final arrangement of the loose fit is unpredictable during assembly, the position tolerance of the slot is better to be modified with an  $\textcircled{L}$  modifier. In such a case, a slot that is at or near its LMC limit of size presents the worst size for the slot as it allows the most misalignment of center planes. A slot closer to its MMC size allows less slack and it becomes the better size for fit.

For this example, Figure 10-18 shows an arrangement of the loose features that is favorable to fit in the main gap. This is because the part has been pushed in a direction that maximizes the main gap and allows the fit to happen. If we can assure this arrangement during assembly we should use the  $\textcircled{M}$  modifier.



**Figure 10-18.** The arrangement of the loose parts that is most favorable to fit related to main gap

When the final arrangement is unpredictable, the worst situation for fit may occur as shown in Figure 10-19. For example, this arrangement may be bolted down in this manner before the next part is inserted. In such cases it is best to use the  $\textcircled{L}$  modifier. To avoid confusion, remember the following rules:

1. If a fit feature is in the path of the main fit and its final arrangement is unpredictable during assembly, use the  $\textcircled{L}$  modifier for its positioning. Also use the  $\textcircled{L}$  modifier when such a feature is referenced as a datum.
2. If a fit feature is in the path of the main fit and its final arrangement is subject to favorable manipulation during assembly, use the  $\textcircled{M}$  modifier for its positioning. Also use the  $\textcircled{M}$  modifier when such a feature is referenced as a datum.
3. Always use the  $\textcircled{M}$  modifier for the main fit features themselves.

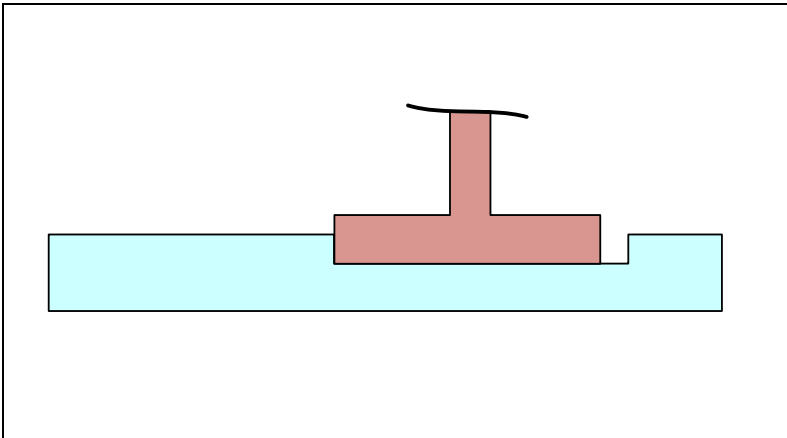


Figure 10-19. The arrangement of the loose parts that is least favorable to fit related to main gap

In this example, we assume that the final arrangement of the slot and rail fit is unpredictable. Figure 10-20 shows the final tolerance specifications for the slot. The primary orienting surface with respect to the assembly is datum-A.

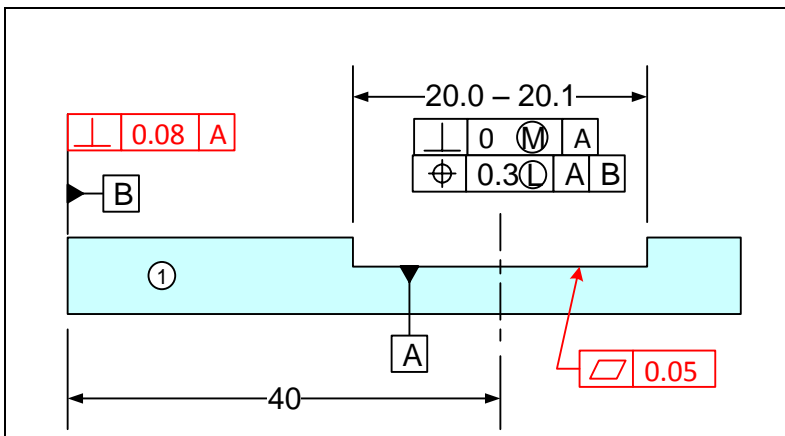


Figure 10-20. Tolerances of part<sub>1</sub> and the slot assuming the final arrangement of the slot fit is unpredictable during assembly

Note that the 0.1 mm represents the combination of size and perpendicularity tolerance. Since orientation control can be done with higher precision than location control with the same process, it is appropriate to use a non-zero position tolerance. In this case, each statement is related to a different fit.

Figure 10-21 shows the tolerance specifications for part<sub>2</sub> and part<sub>3</sub>. The tolerancing of part<sub>2</sub> is simple and requires just a profile tolerance. The primary orienting surface for part<sub>2</sub> is assumed to be datum-A. For part<sub>3</sub>, we first specify the precision requirements necessary to fit to part<sub>1</sub>. The primary orienting surface is datum-A.

The perpendicularity tolerance at MMC applied to the rail feature is to meet the fit requirement to the slot. Next, we control the left face of the part with respect to the center plane of the rail using a profile tolerance statement.

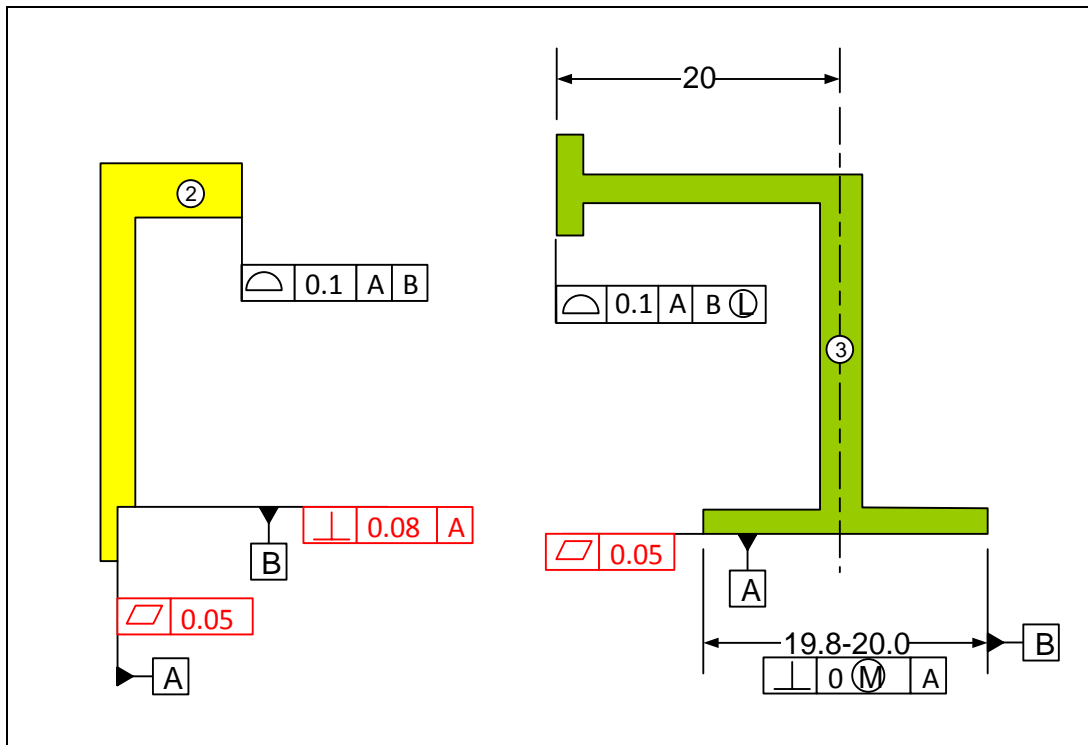


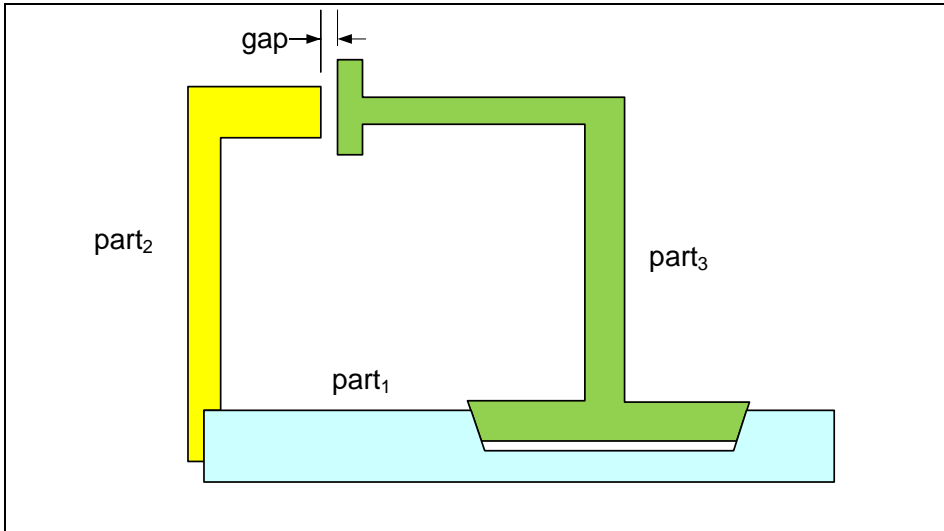
Figure 10-21. The initial assignment of tolerances

The  $\textcircled{L}$  modifier is used on this datum feature because it was assumed that any slack in this fit cannot be favorably positioned during assembly. Therefore, the least material boundary (LMB) is the preferred specification. During inspection, if the rail happens to be larger than its LMB value of 19.8 mm, a bonus value would be added to the profile tolerance. For example, if the rail's actual mating envelope (size plus orientation deviation) is 19.9 mm, the profile tolerance value can be increased by 0.1 mm resulting in a total of 0.2 mm profile tolerance.

### Example-7: A multipart tolerance design with tapered slot features

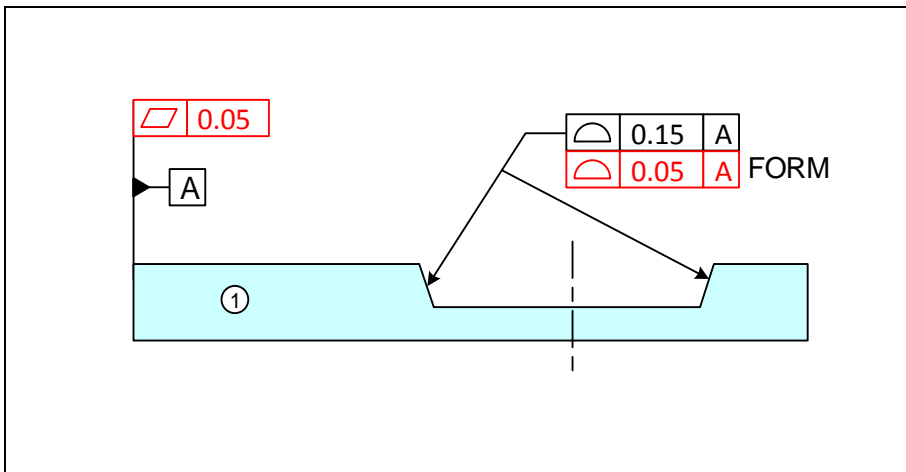
One method of eliminating the influence of loose fits that can take an unpredictable arrangement during assembly is to use tapered slot fits. Tapered fits eliminate play and misalignment in the fit. Figure 10-22 shows the same three-part assembly as in the previous problem with one change. The slot and rail features have been replaced with tapered slot and rail features. Another benefit of the tapered slot fits is that the sizes of the fitting features are no longer critical as the design eliminates the possibility of play in loose fits. Size tolerances become important, however, if precision alignments is to be maintained in the vertical direction as well as horizontal. Tapered shapes, however, are

usually more costly to manufacture with high precision compared to straight slots and rails.



**Figure 10-22. Tapered slots and rails eliminate play and fit misalignment**

Figure 10-23 shows how the tolerancing scheme would change when the slot and rail is replaced by tapered slot and rail features. Since tapered features are not regular features-of-size, profile tolerances should be used to control every precision aspect of tapered features. Following the presumed order of assembly, the tolerancing requirements of part<sub>1</sub> is addressed first. The left edge surface is the feature that contacts part<sub>2</sub> and is selected as the primary orienting datum-A. Since the slot can also be used as the primary orienting datum we must also control the slot form and orientation with high precision. The precision form and orientation control is necessary to reduce the feature's angular distortion inaccuracies relative to datum-A.



**Figure 10-23. The initial assignment of tolerances for part<sub>1</sub>**

The specifications for part<sub>2</sub> remain the same as in the previous example while the specifications for part<sub>3</sub> is shown in Figure 10-24.

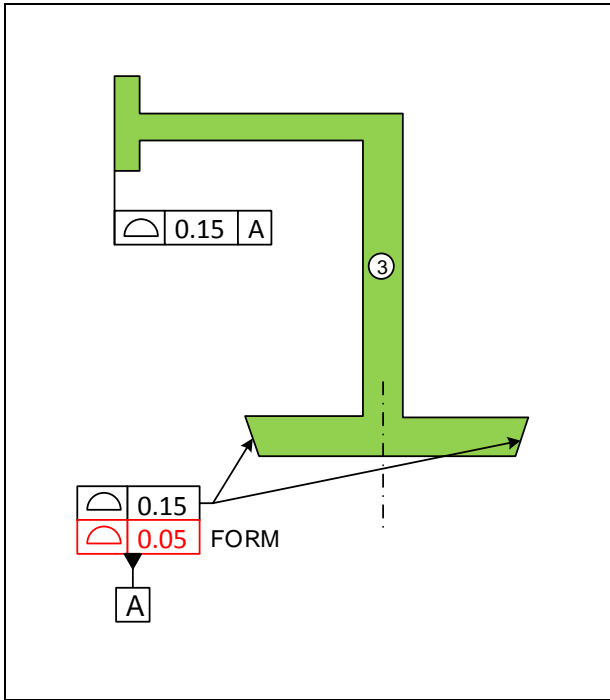


Figure 10-24. The initial assignment of tolerances for part<sub>3</sub>

The pair of tapered sliding surfaces is controlled for size using the upper profile statement to within 0.15 mm. The lower profile statement is for finer control of feature form. This pair of surfaces is selected as the primary orienting feature. Datum-A defines the center plane of the tapered slot for controlling horizontal distances.

### Example-8: A multipart tolerance design with cylindrical fit features

Consider the simple three-part assembly with cylindrical features as shown in Figure 10-25. Part numbers indicate the presumed order of assembly.

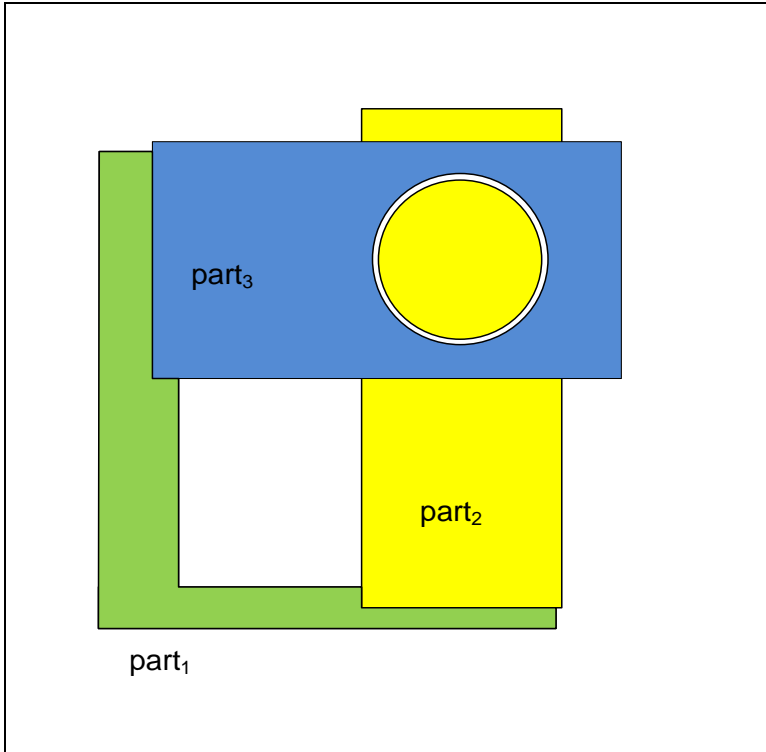


Figure 10-25. A three-part assembly with cylindrical fit features

Figure 10-26 shows the initial theoretical dimensions and tolerances of part<sub>1</sub>.

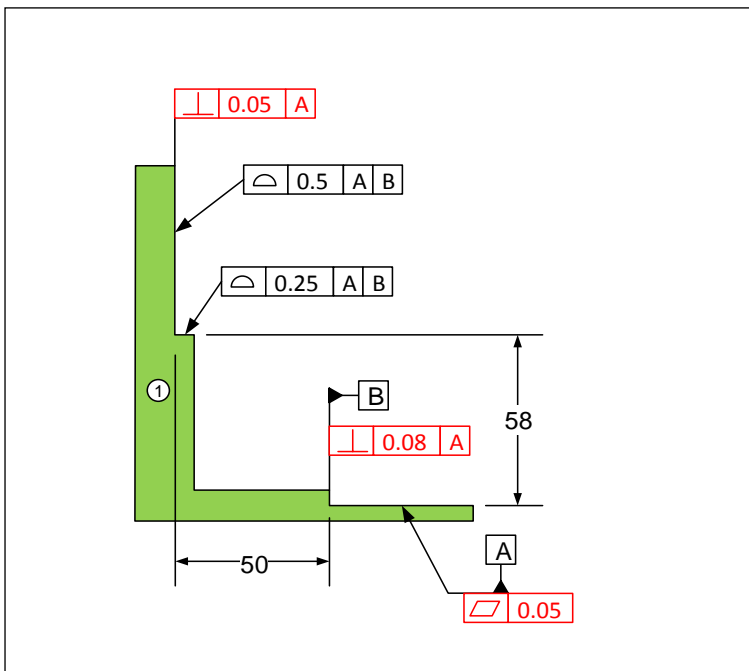
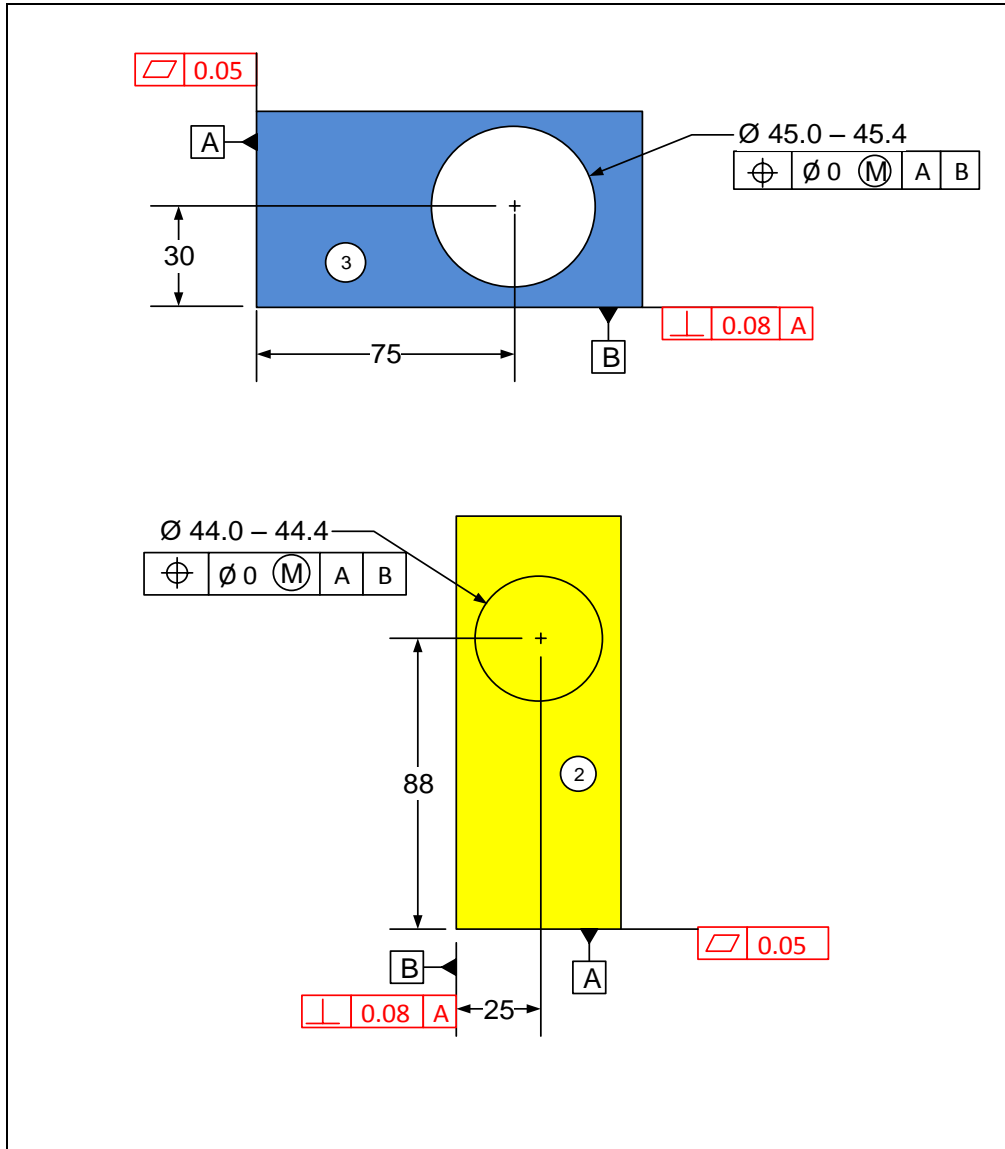


Figure 10-26. Initial tolerances for part<sub>1</sub>

The horizontal surface feature on the right side that contacts part<sub>2</sub> is used as the primary orienting datum. The vertical edge is selected as the secondary locating datum. Since the left-side vertical surface is an equally valid choice for the primary orienting datum, the orientation of the vertical surface with respect to datum-A is controlled with high precision. For part<sub>1</sub>, the upper features are controlled by profile tolerances.

The theoretical dimensions are selected such that the theoretical axis of the hole and the theoretical axis of the boss align. This is always the best practice in order to allow the widest tolerances for fit. Figure 10-27 shows the specifications for part<sub>2</sub> and part<sub>3</sub>.



**Figure 10-27. Initial tolerances for part<sub>2</sub> and part<sub>3</sub>**

The explanation of these tolerances is left as an exercise.

### Example-9: Multipart fits with loose fit features

Consider a variation of the same three-part assembly of the previous example. In this case slots have been added to locate the parts with fit features as shown in Figure 10-28. The part numbers indicate the presumed order of assembly for tolerancing purposes.

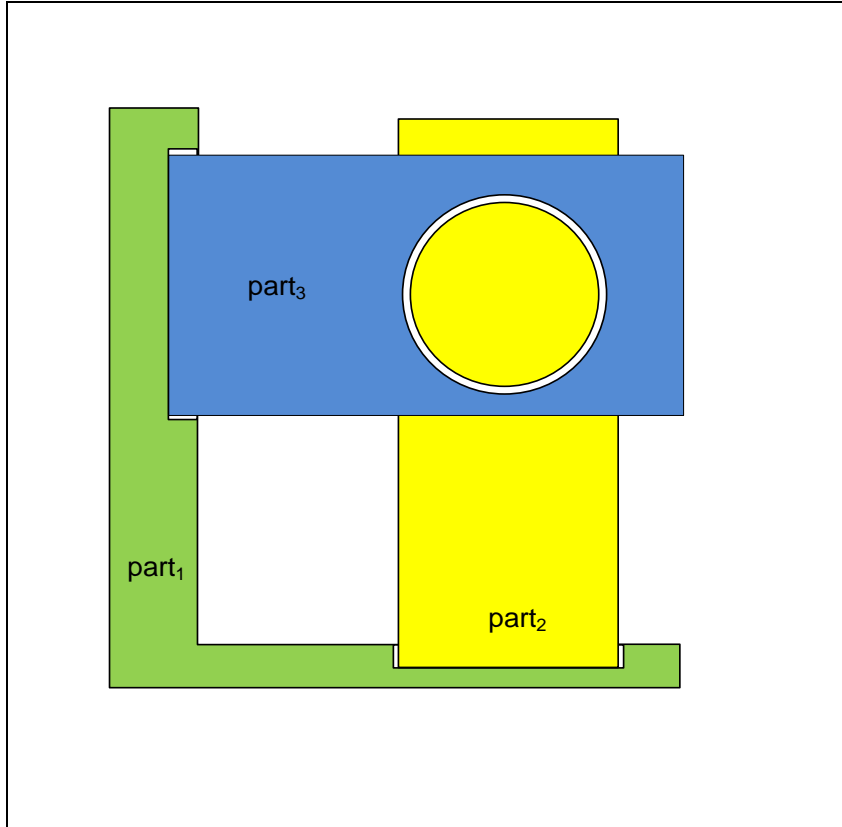
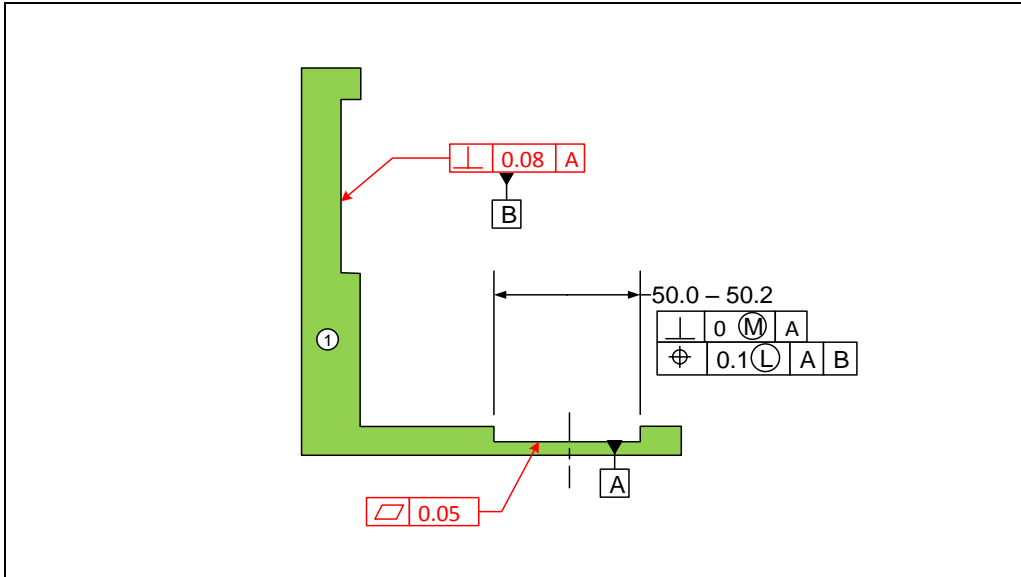


Figure 10-28. A three-part assembly with loose fit features and a cylindrical main fit

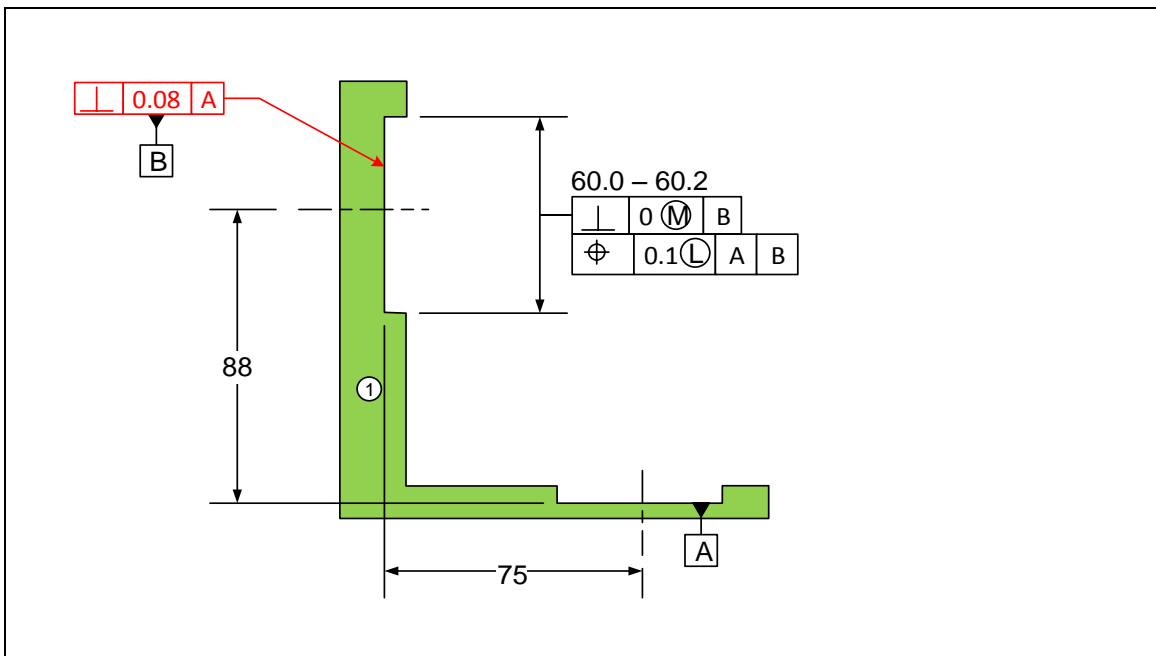
We will start with the tolerancing specifications for part<sub>1</sub>. Figure 10-29 shows the feature and tolerances for part<sub>1</sub> related to fit to part<sub>2</sub>. The horizontal surface feature on the right side that contacts part<sub>2</sub> is used as the primary orienting datum. The vertical edge on the left side is selected as the secondary locating datum. We could have also selected the center plane of the horizontal slot as the secondary datum.



**Figure 10-29. Initial tolerances for the lower slot of part<sub>1</sub>**

The perpendicularity statement for the lower slot is necessary to assure its fit to the rail of part<sub>2</sub> while the lower position tolerance is to control the influence of the size and the position of the slot on the main fit gap.

We now add the necessary tolerances to the upper slot for the fit of part<sub>3</sub>. To focus on the upper slot, the tolerances associated with the lower features are not shown. Figure 10-30 shows the result.



**Figure 10-30. Initial tolerances for the upper slot of part<sub>1</sub>**

The perpendicularity tolerance is needed because the upper slot has an orientation-constrained fit to part<sub>3</sub>. The position tolerance limits the influence of the upper slot on the fit gap. Figure 10-31 shows the tolerancing of part<sub>2</sub> and part<sub>3</sub>.

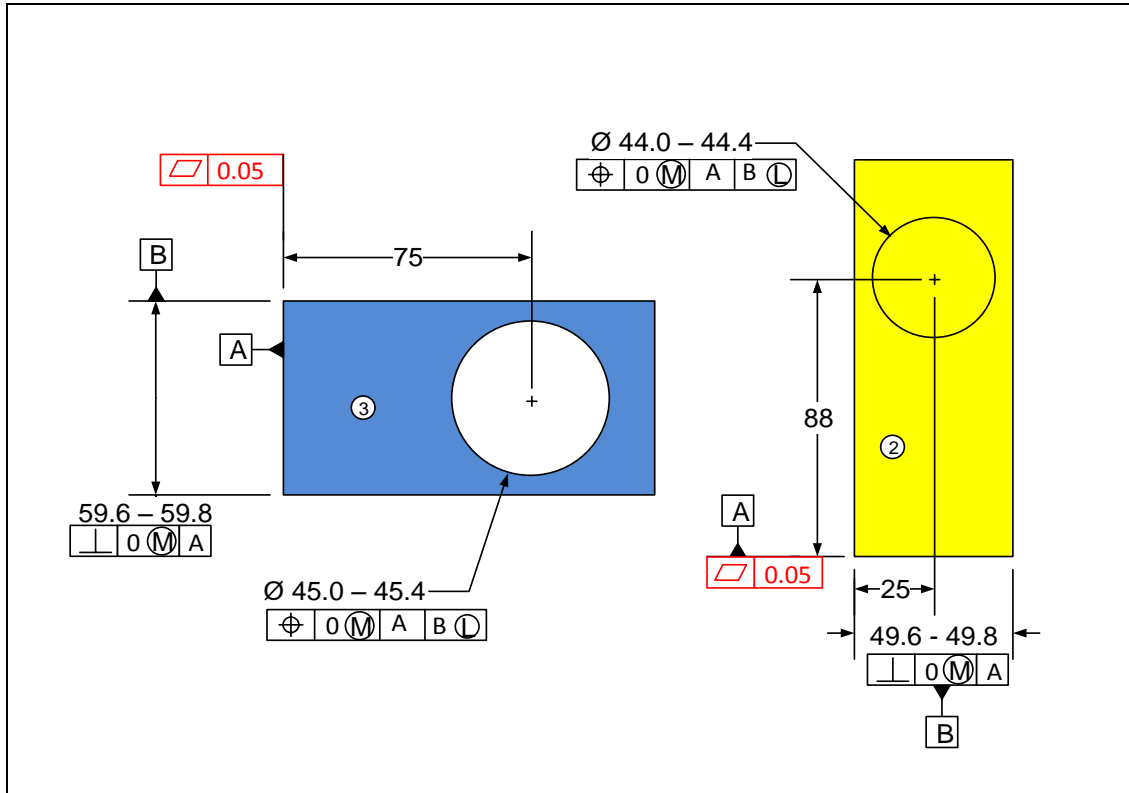


Figure 10-31. Initial tolerances for part<sub>2</sub> and part<sub>3</sub>

Datum-B for both parts is specified at LMB as the fit arrangement of these datum features is assumed to be unpredictable during assembly. The theoretical positions are specified such that the center of the hole and boss align.

### Example-10: A multipart fit with multiple loose fits

Consider the four-part assembly shown in Figure 10-32. The part numbers indicate the presumed order of assembly for tolerancing purposes. There are three fit features in the path of the final fit between the boss and the hole. If the parts are to be put together randomly, the worst situation for fit is when all slots and rails are at their LMC limit of size creating the widest slacks in the fits.

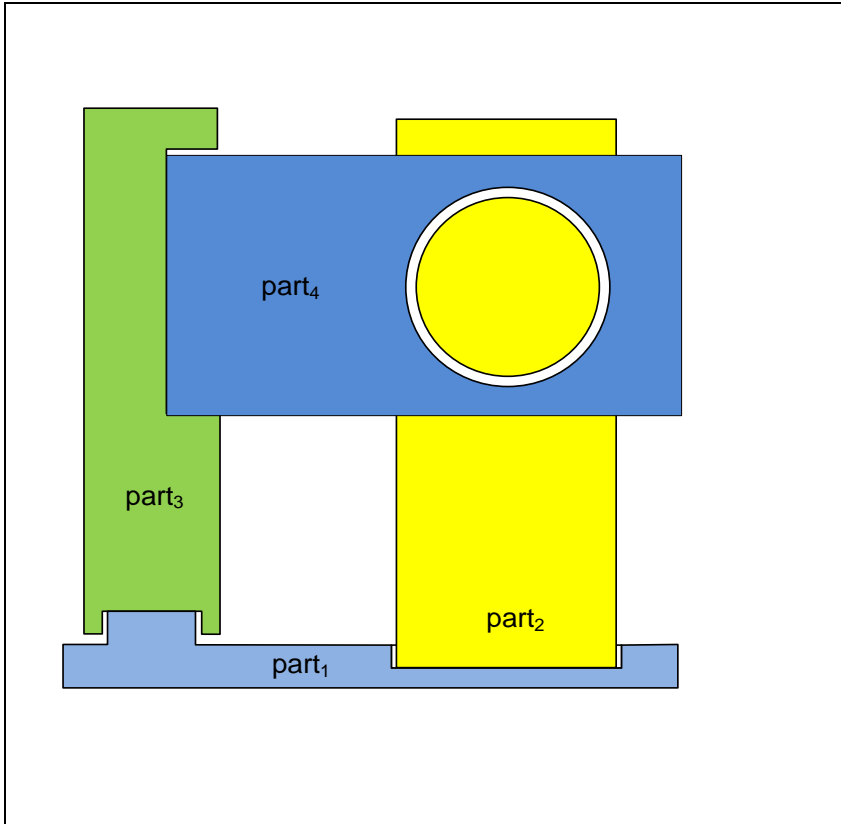


Figure 10-32. A five-part assembly with three fit features in the path of the main cylindrical fit

Figure 10-33 shows the tolerances for part<sub>1</sub>.

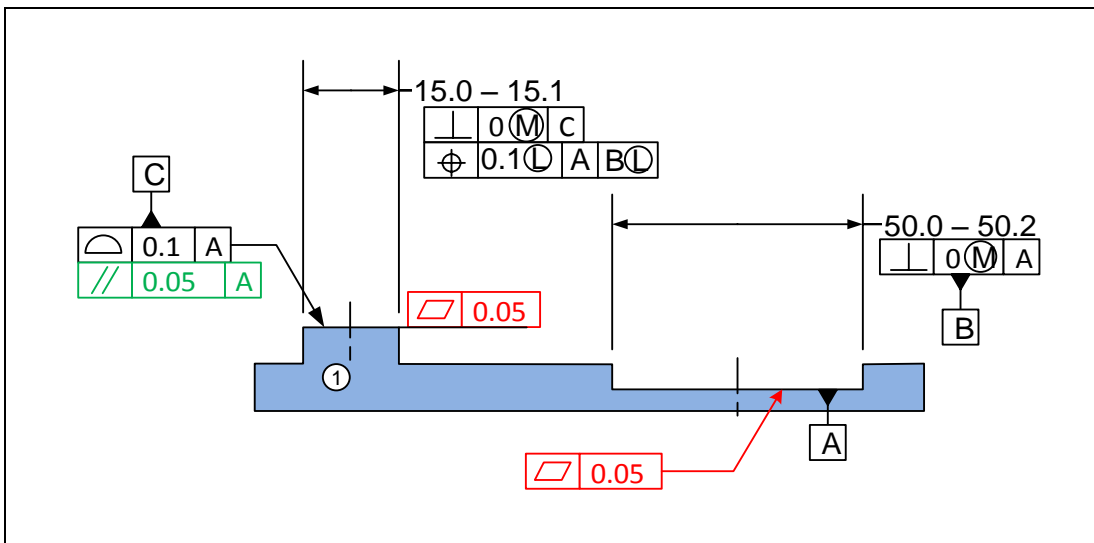


Figure 10-33. Initial tolerances for part<sub>1</sub>

The first fit is the slot feature fit to the rail of part<sub>2</sub>. The perpendicularity tolerance at MMC is necessary for this orientation-constrained fit. Datum-A is chosen as the primary

orienting datum. Datum-C can also be chosen as the primary orienting datum. Datum-A is selected based on the presumed order of assembly. Since datum-C controls the orientation of part<sub>3</sub>, the orientation of datum-C with respect to datum-A is controlled with high precision to reduce the distortion effects. The slot center plane is chosen as the secondary locating datum. The rail has a perpendicularity tolerance at MMC for its direct orientation-constrained fit to the slot of part<sub>3</sub>.

The position of the rail with respect to the slot is controlled at LMC, assuming this fit cannot be favorably positioned during assembly. The datum-B is specified at LMB also because the slot datum feature is a loose fit feature with an unpredictable arrangement during assembly. Figure 10-34 shows the tolerancing for part<sub>3</sub>.

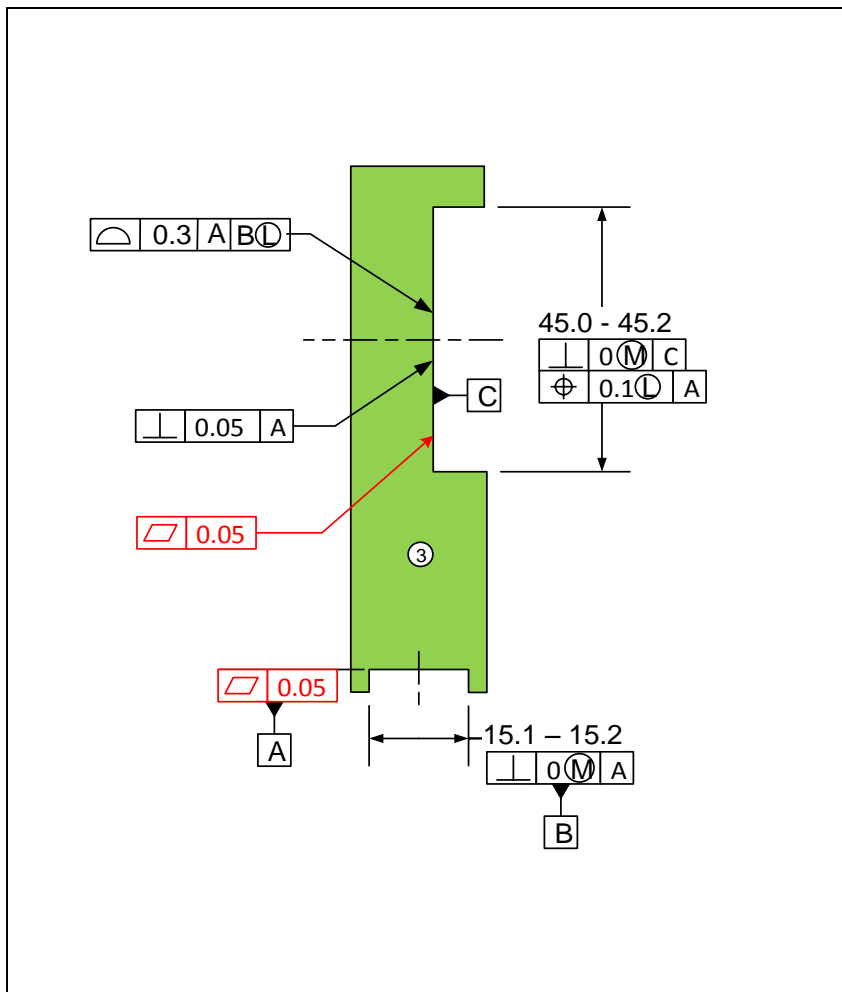


Figure 10-34. Initial tolerances for part<sub>3</sub>

Datum-A and datum-B are selected as the primary orientating and secondary locating features. Datum-B slot has an orientation-constrained fit to part<sub>1</sub>. Datum-C surface controls the orientation of part<sub>4</sub> and for that reason the perpendicularity of datum-C with respect to datum-A is controlled with high precision. The upper slot has an orientation-

constrained fit to part<sub>4</sub> resulting in a perpendicularity tolerance specification with zero value at MMC. The position of the upper slot controls the vertical location of part<sub>4</sub>. The slot is controlled with a position tolerance value of 0.1 mm at LMC. Datum-C controls the horizontal location of part<sub>4</sub>. A profile tolerance with a value on 0.3 mm is applied to datum-C surface. This profile tolerance is located with respect to datum-B and since the datum fit arrangement is unpredictable, the datum-B specification is specified at LMB. Tolerancing of part<sub>2</sub> and part<sub>4</sub> are identical to the ones in the previous example.

### Example-11: Another multipart fit with multiple loose fits

In the assembly shown in Figure 10-35, part<sub>4</sub> is known to be assembled last. The fit arrangement involving the slot features is unlikely to be adjustable for favorable positioning during assembly.

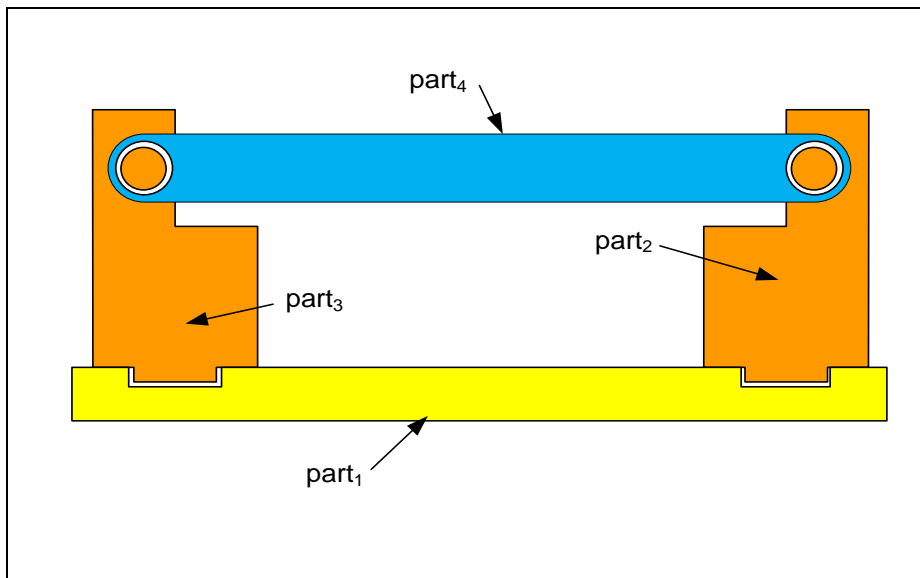


Figure 10-35. A four-part assembly

Figure 10-36 shows the features and tolerances of part<sub>1</sub>. The top surface is the primary orienting datum. The perpendicularity tolerances are necessary for direct fits and the position statement is needed to limit the influence of the size and distance between the slots on the fit of part<sub>4</sub> bar. Therefore, the positions of the slot and rail features are modified by  $\text{Ⓢ}$  modifiers.

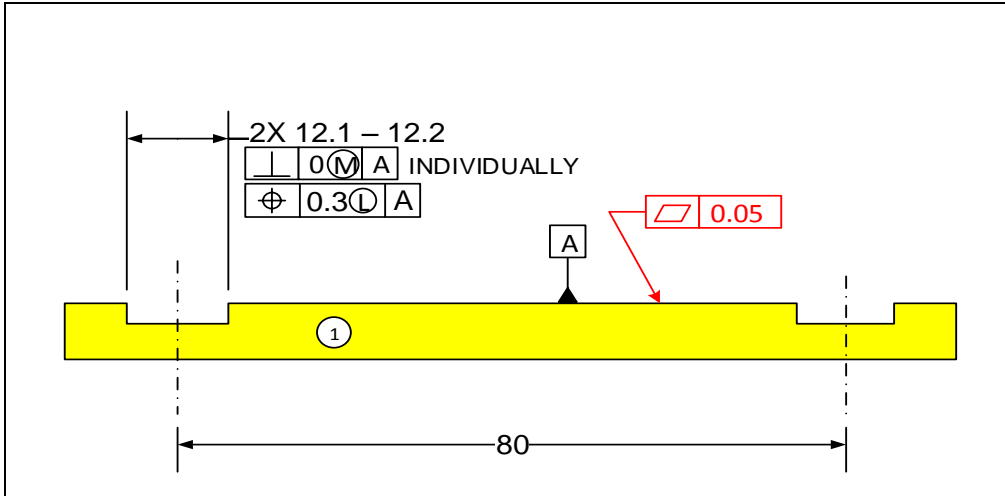


Figure 10-36. Initial tolerances of part<sub>1</sub>

Figure 10-37 shows the features and tolerances of part<sub>2</sub> and part<sub>3</sub>. The perpendicularity tolerance is needed for the direct fit. The position tolerance is necessary to assure the fit of the final piece, which is the part<sub>4</sub> bar. The position tolerance of the cylindrical fit feature is specified at MMC as this feature fits to the last part and is also the main fit feature. Since the final arrangement of the slot datum cannot be altered during assembly the slot datum is specified with an LMB specification.

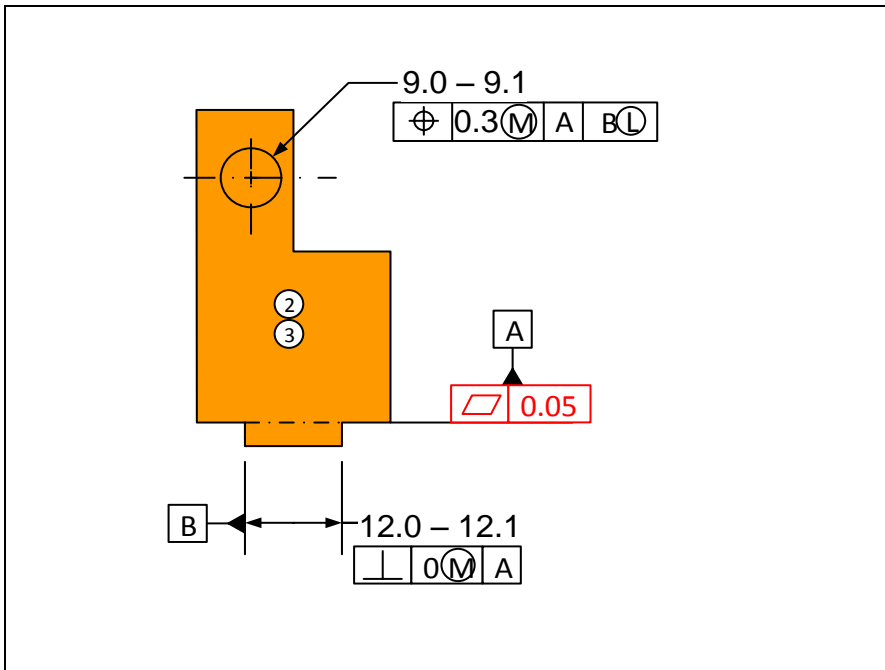


Figure 10-37. Initial tolerances for part<sub>2</sub> and part<sub>3</sub>

Figure 10-38 shows the features and tolerances of part<sub>4</sub> that is placed last into the assembly.

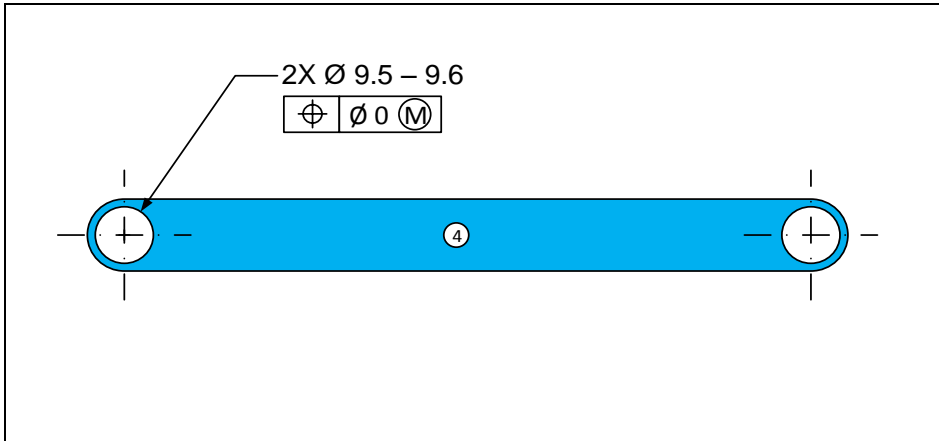


Figure 10-38. Initial tolerances for part<sub>4</sub>

### Example-12: Influence of orientation accuracy on fit

When analyzing an assembly for fit we must be aware of orientation deviations that influence the fit. An example is shown in Figure 10-39.

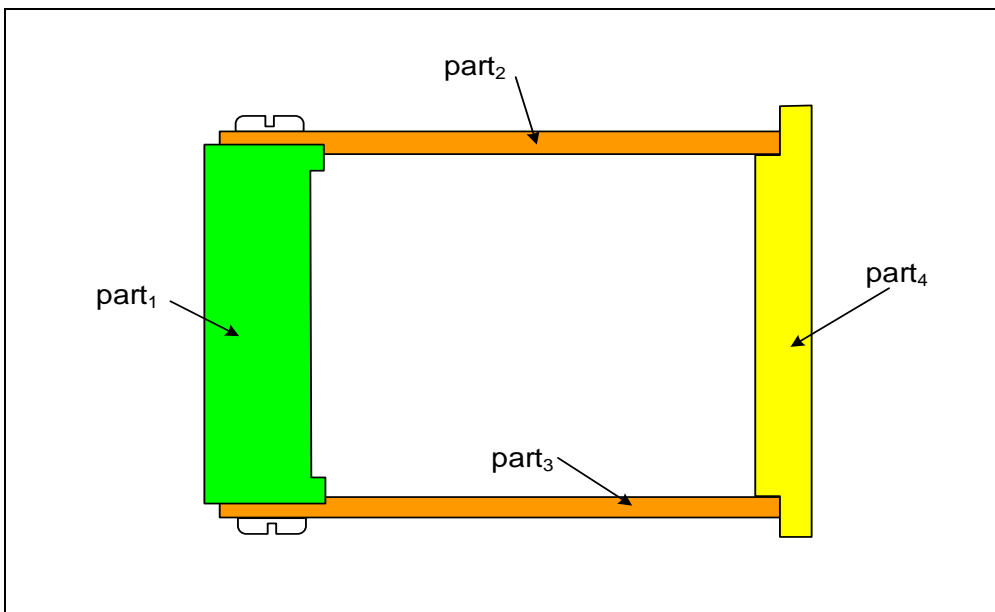
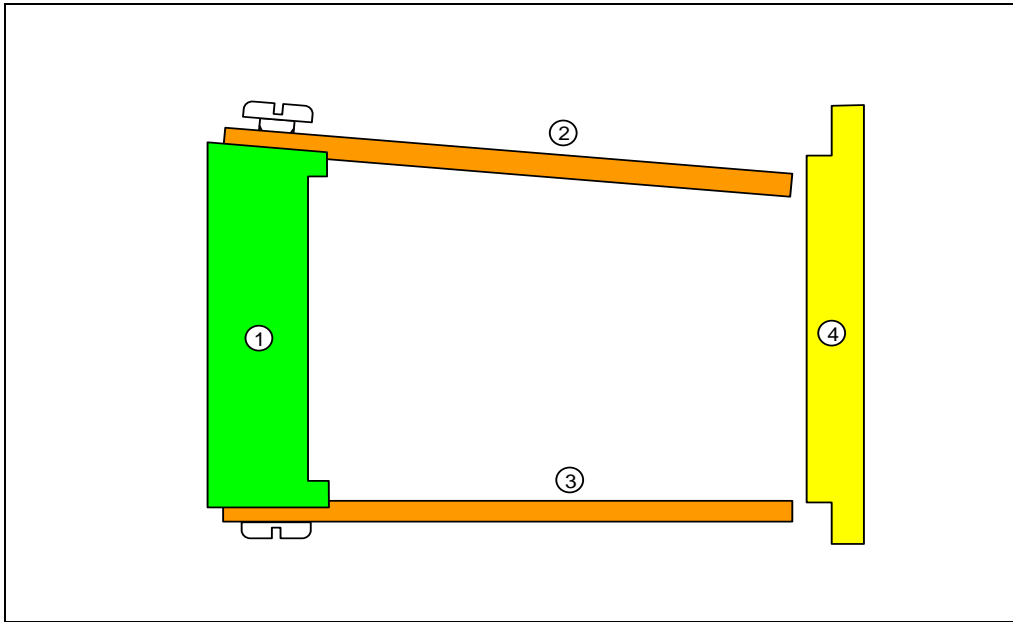


Figure 10-39. The parallelness of top and bottom surfaces of part<sub>1</sub> is critical to fit

The top and bottom plates have forced firm contacts with the two faces of part<sub>1</sub> due to the presence of the fasteners. Sufficient parallelness control should be applied between these

surfaces to reduce the distortion effects. Figure 10-40 shows an exaggerated graphic of this situation.



**Figure 10-40. The adverse effect of excessive angular distortion on fit**

Consider the specifications shown in Figure 10-41 for part<sub>1</sub>. The top and bottom surfaces must be sufficiently parallel to reduce the projection distortion effect. The parallelness tolerance statement is shown in green. The explanation of tolerances for part<sub>2</sub> and part<sub>4</sub> is straightforward and left as an exercise. The perpendicularity tolerance is necessary to set up a reference surface (datum) for locating the fastener holes. Neither the datum label nor the fastener holes are shown. The profile tolerance controls the height of the block for proper fit to the end part (part<sub>4</sub>). The explanation of tolerances for other parts is left as an exercise.

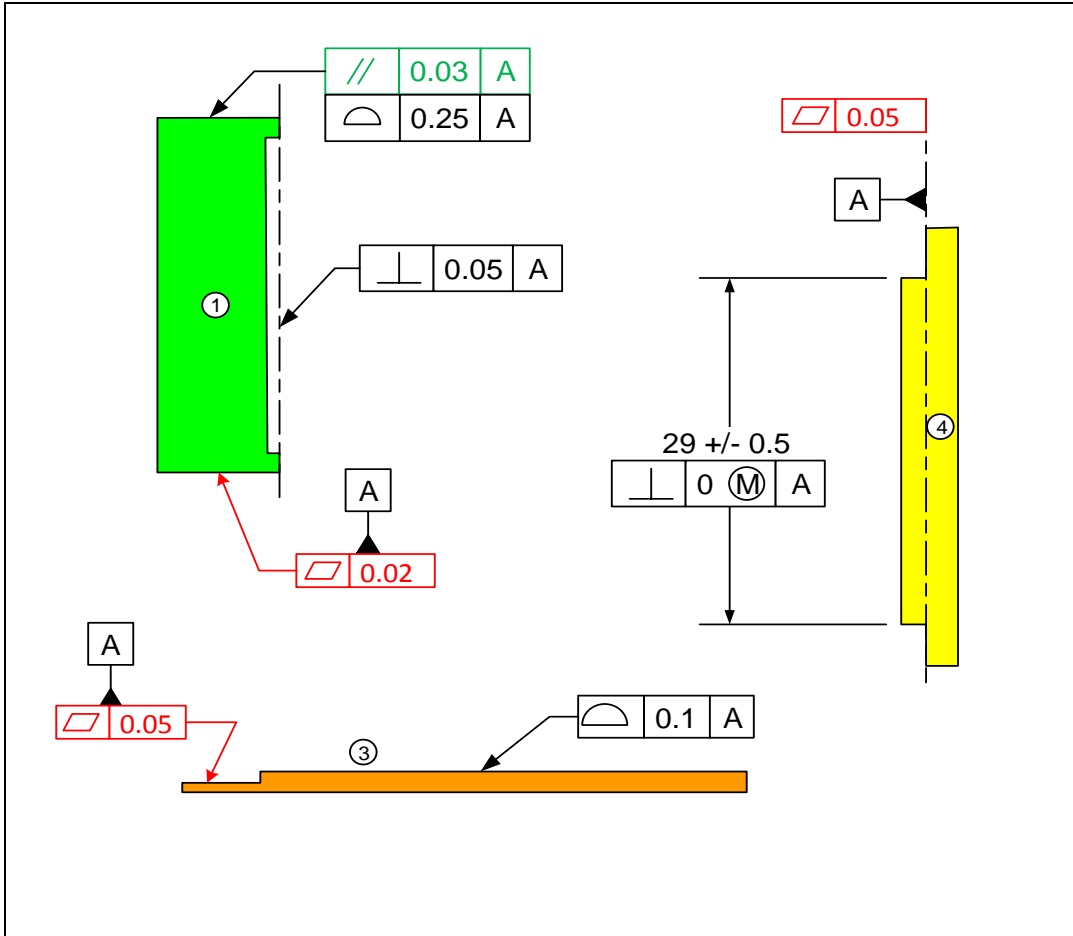


Figure 10-41. Initial assignment of tolerances

Figure 10-42 shows the maximum possible deviation caused by the angular projection effect when only the size tolerance ( $t = 1 \text{ mm}$ ) is specified without parallelness control.

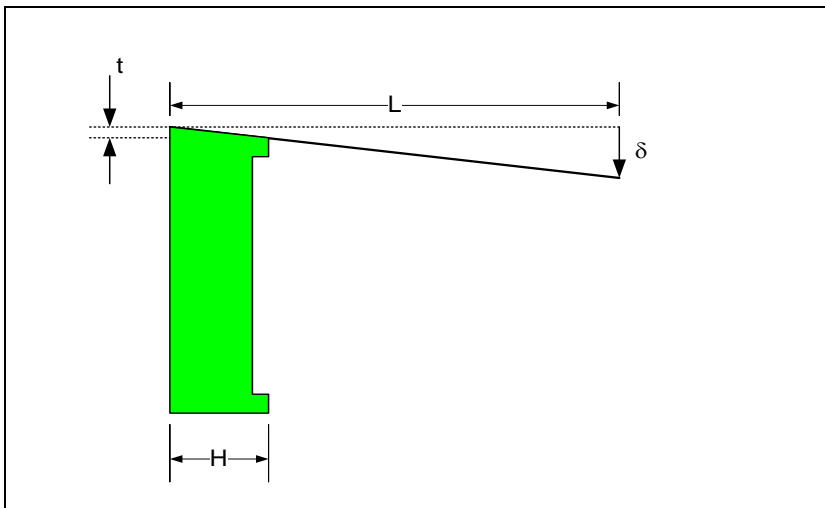


Figure 10-42. The magnified effect of distortion error when projected out a long distance

The size tolerance of the block is  $t = 1$  mm, the length of the overhang, or projection, is  $L = 50$  mm, the width of the block is  $H = 10$  mm, and  $\delta$  is the vector that represents the effect of angular distortion.  $\delta$  can be found as

$$\delta = \frac{L}{H}t = 5 \text{ mm}$$

This  $\delta$  vector is similar to the parallelness tolerance except that its value is magnified by the projection length. The  $\delta$  vector is shown pointing downward but it can point in either direction.

**Example-13: A multipart assembly with a press fit insert**

In the assembly shown in Figure 10-43, part<sub>1</sub> is attached to the frame of a machine. The location of part<sub>1</sub> on the machine is not important. Part<sub>1</sub> has a boss which fits the inner diameter of a plain bearing or bushing (part<sub>4</sub>). The bushing is press-fit into the bearing hole in part<sub>3</sub>. Part<sub>3</sub> with the part<sub>4</sub> insert is placed last into the assembly.

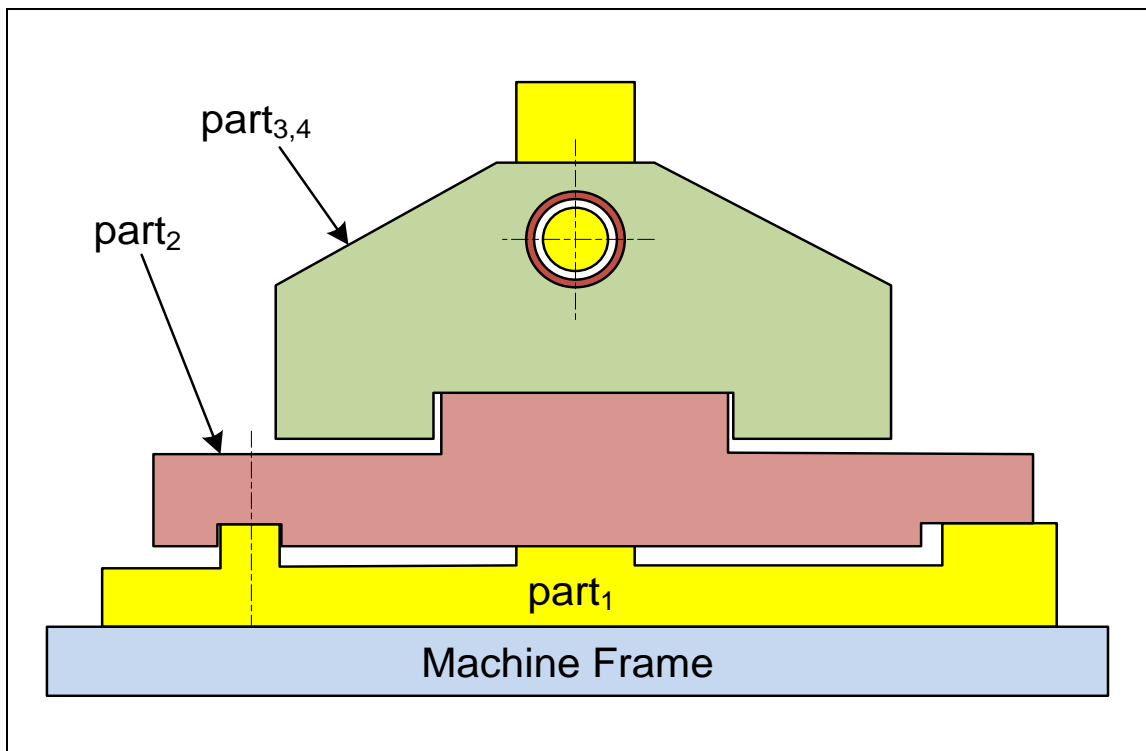


Figure 10-43. A multipart assembly with a press-fit bearing

The assembly requires the parts to be put together according to the order indicated. The final arrangement of the slot and rail fit between part<sub>1</sub> and part<sub>2</sub> is unpredictable during assembly. Figure 10-44 shows the tolerance specifications for part<sub>1</sub>. The basic dimensions are selected such that the theoretical axis of the hole and the theoretical axis of the boss align.

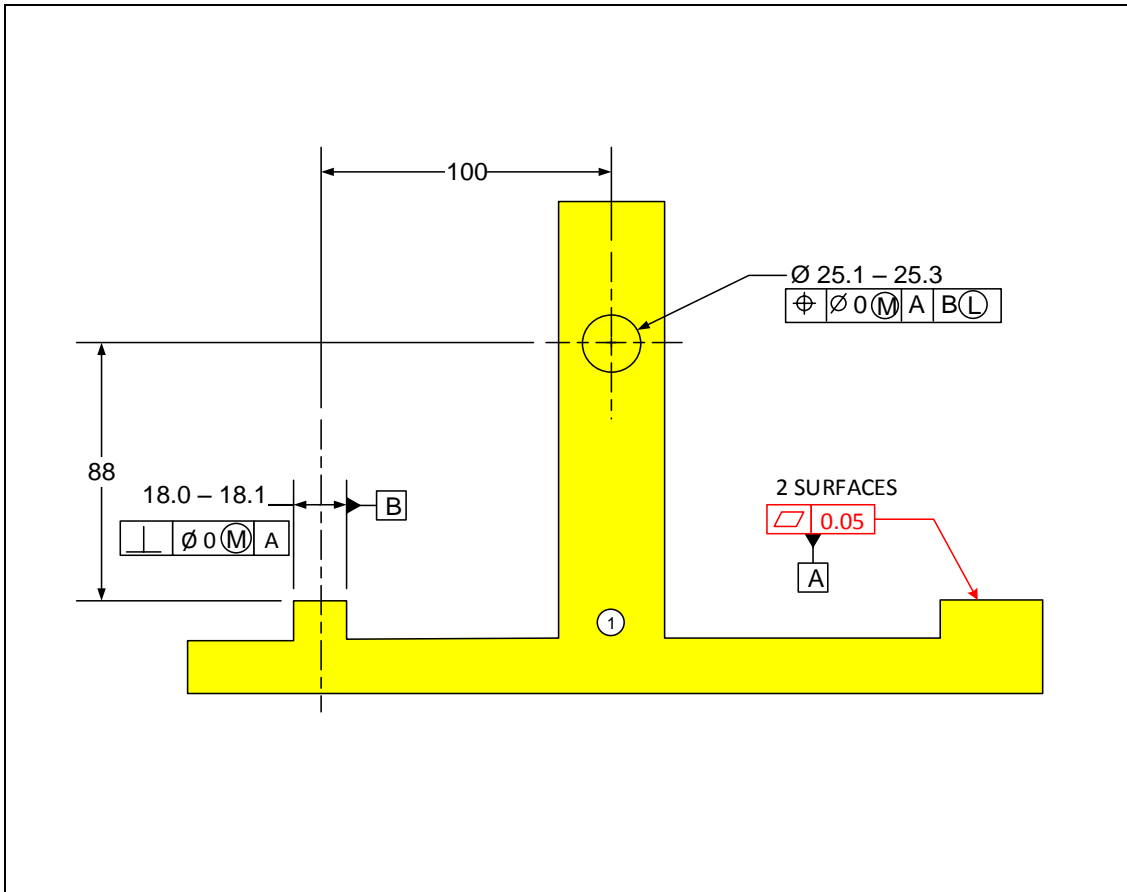


Figure 10-44. Initial tolerance assignment for part<sub>1</sub>

Datum-A is the primary orienting surface. The flatness tolerance controls the flatness and co-planarity of the datum-A pair of surfaces. The rail perpendicularity tolerance is for the orientation-constrained fit to the rail of part<sub>2</sub>. Since the fit of the rail is unpredictable during assembly the  $\text{Ⓜ}$  modifier will be used when referenced as a datum such as in the position tolerance statement. Figure 10-45 shows the initial basic dimensions and tolerances for part<sub>2</sub>.

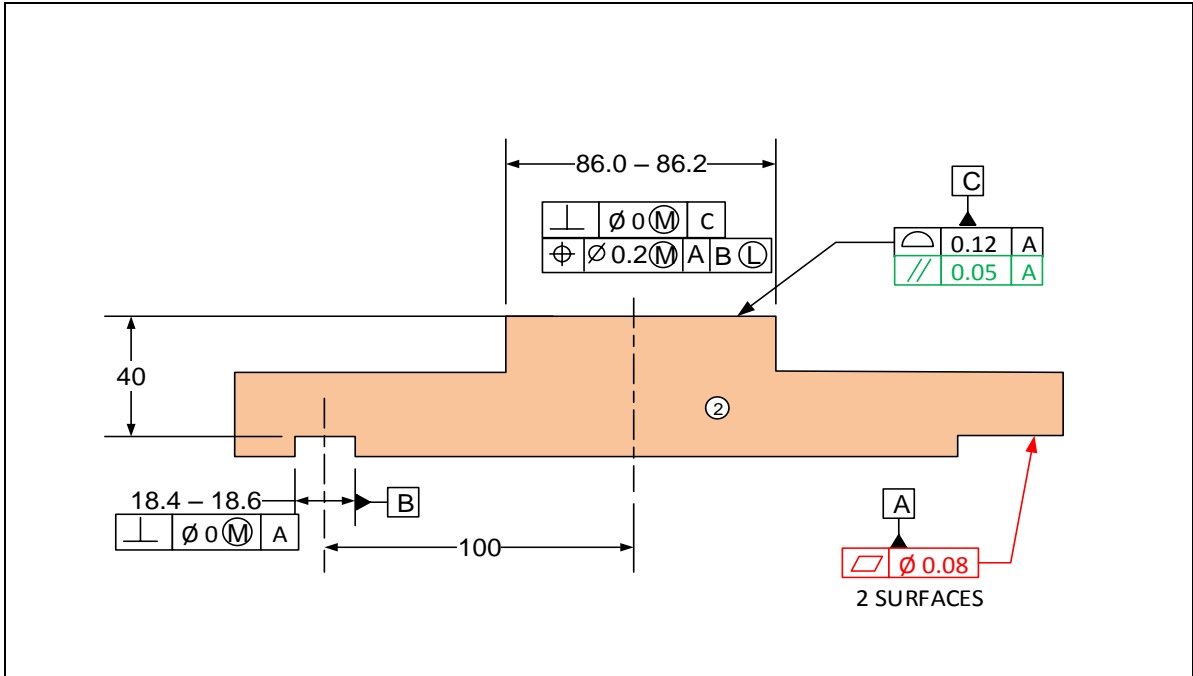


Figure 10-45. Initial tolerance assignment for part<sub>2</sub>

The primary orienting surfaces are chosen as datum-A. The slot is selected as the secondary locating datum-B. The surface designated as datum-C orients part<sub>3,4</sub> and is specified to be parallel to datum-A with high precision. The slot and rail features are set up for orientation-constrained fits. Since the slot fit is in the path of main fit and its fit arrangement is unpredictable, the slot datum is referenced LMB with an  $\text{L}$  modifier. The fit of the rail itself, however, is predictable as it fits last. For that reason, the rail feature is used with an  $\text{M}$  modifier. Figure 10-46 shows the initial basic dimensions and tolerances for part<sub>3</sub> and the insert part<sub>4</sub>. The tolerances involving press-fit inserts were presented before in Chapter-9.

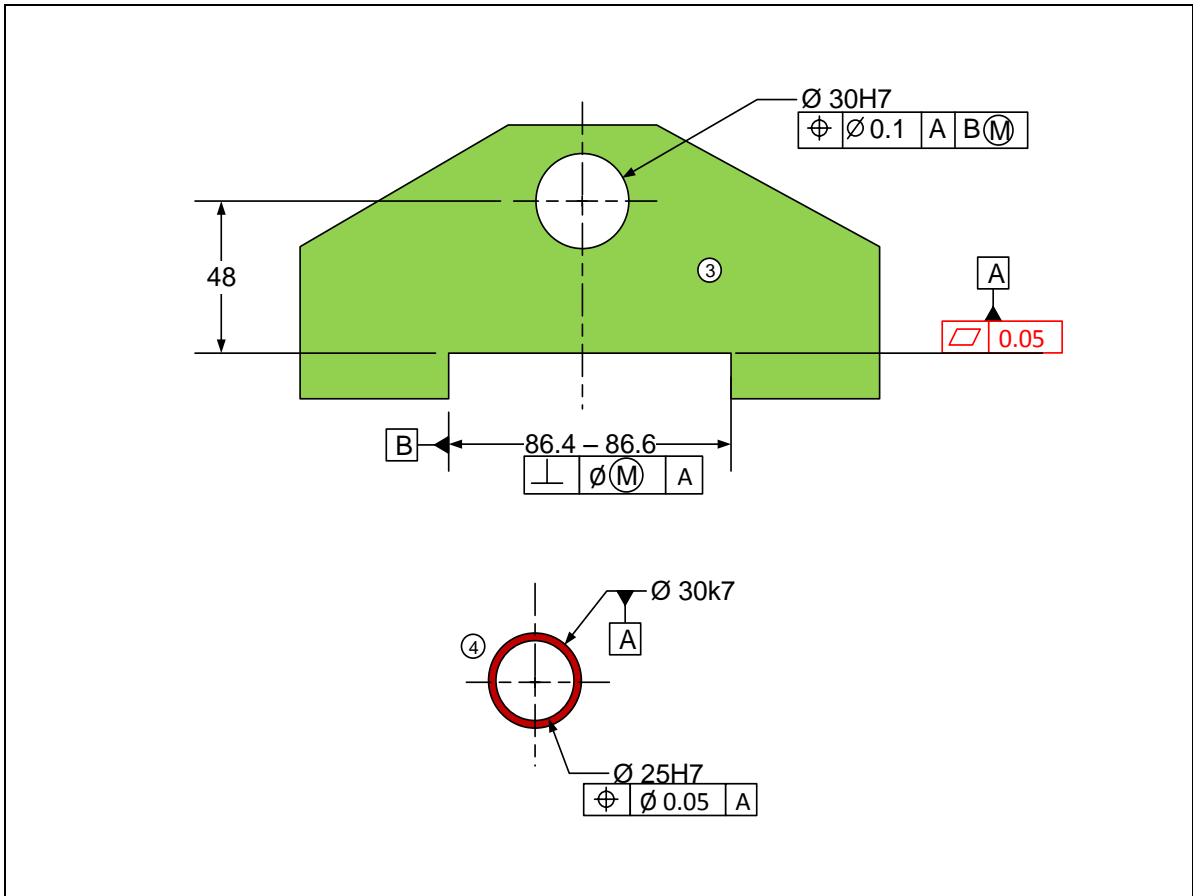


Figure 10-46. Initial tolerance assignment for part 2

The 30H7/k7 creates a tight fit between the insert and the hole. For this last part to be inserted into the assembly the slack in the slot and rail fit can be adjusted during assembly to achieve a fit, hence, the slot datum reference is modified at MMB.

#### Example-14: Design for function - cutting blades

Figure 10-47 is a simple representation of a pair of cutter blades firmly attached to a spindle. The attachment screws are not shown. It is important to control the distance between the ends of the blades. It is also important for the blades to be perpendicular to the axis of the spindle to prevent axial wobble and vibration of the cutting blades. The most important aspect of the function of the assembly is for the distance between the two blades to remain constant with high precision. A constant distance between the blades creates cleaner cuts and reduces vibration and cutting forces.

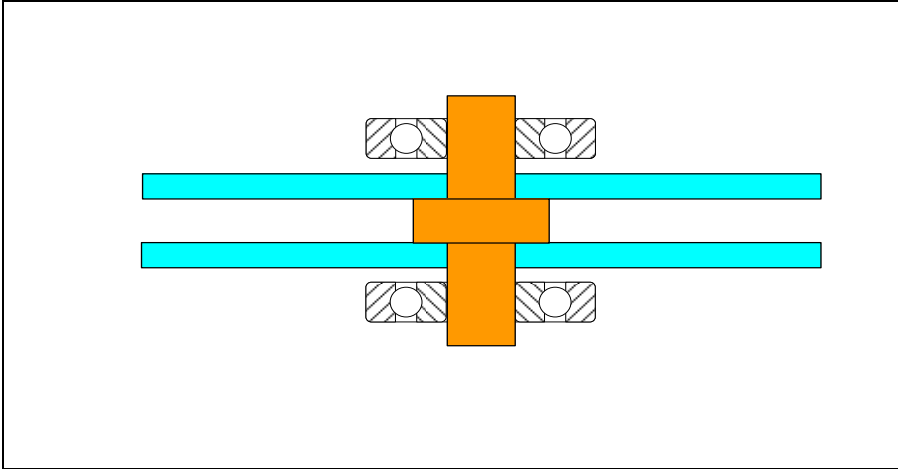


Figure 10-47. A schematic representation of a pair of cutting blades

Figure 10-48 shows the required tolerances for the spindle. The function related specifications are shown in blue.

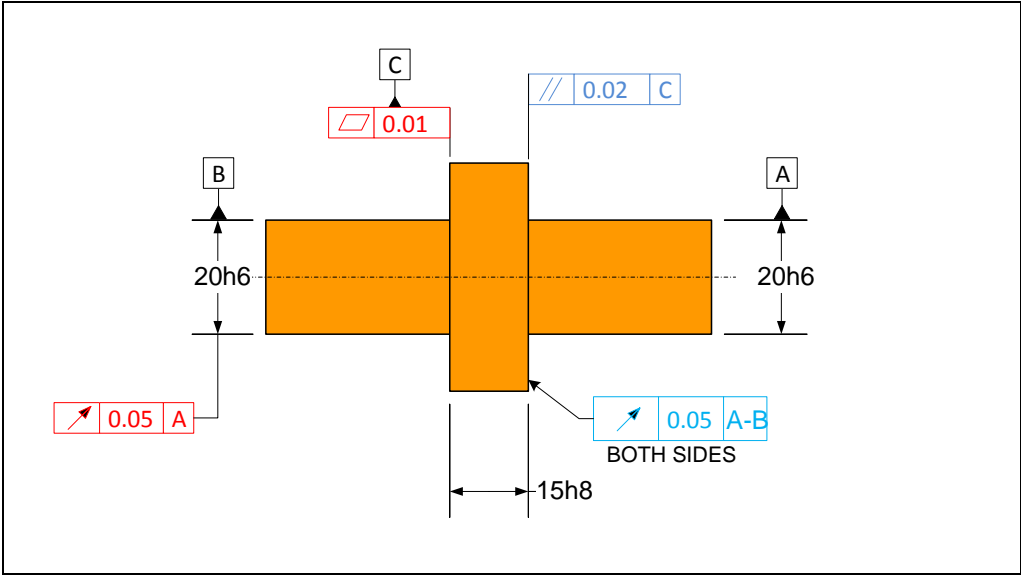


Figure 10-48. Initial tolerances for the spindle

The high precision parallelness assures a constant distance between the two blades. The runout tolerances keep the surfaces square to the axis of rotation.

## Exercises

4. Figure 10-49 shows an assembly of three parts. Tolerance the features of the three parts relevant to the gap shown in the figure. Set up the theoretical dimensions such that the gap is theoretically 1 mm.

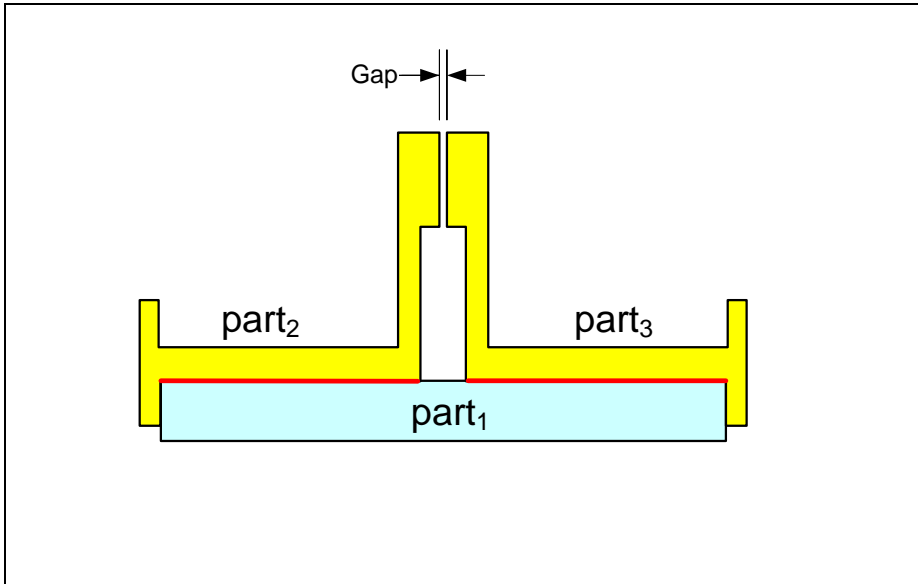


Figure 10-49. Assembly of three parts

5. Figure 10-50 shows an attachment of three parts to a machine frame. Tolerance the features of the three parts related to the three-part fit. Assign the initial theoretical dimensions such that the parts fit together with a 0.5 mm gap.

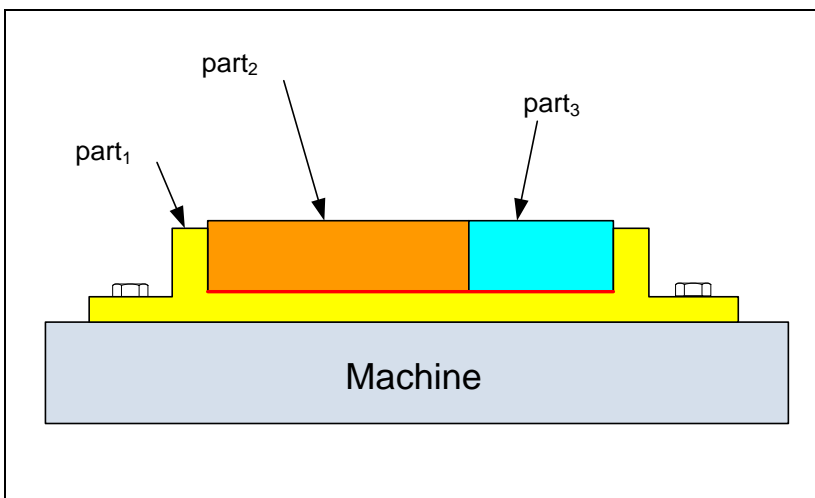


Figure 10-50. Assembly of three parts

6. Figure 10-51 shows an attachment of three parts to a machine frame with loose bolts and nuts. Tolerance the features of the three parts related to the three-part fit. The bolts and nuts are M8. The dimensioning of one the T-shaped part is shown in Figure 10-52.

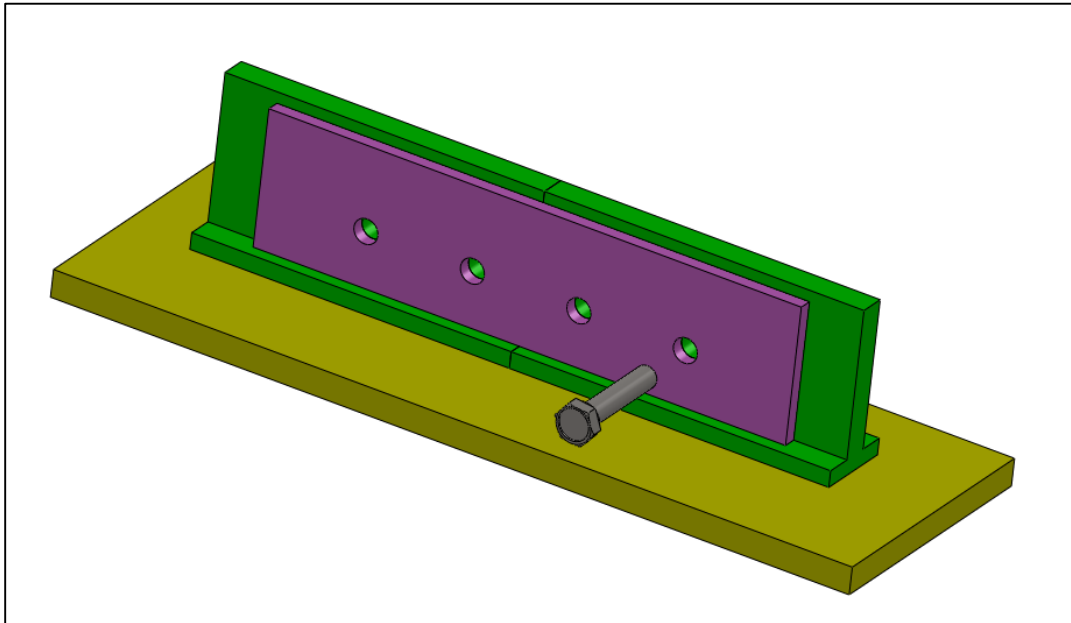


Figure 10-51. Assembly of three parts with loose bolts and nuts

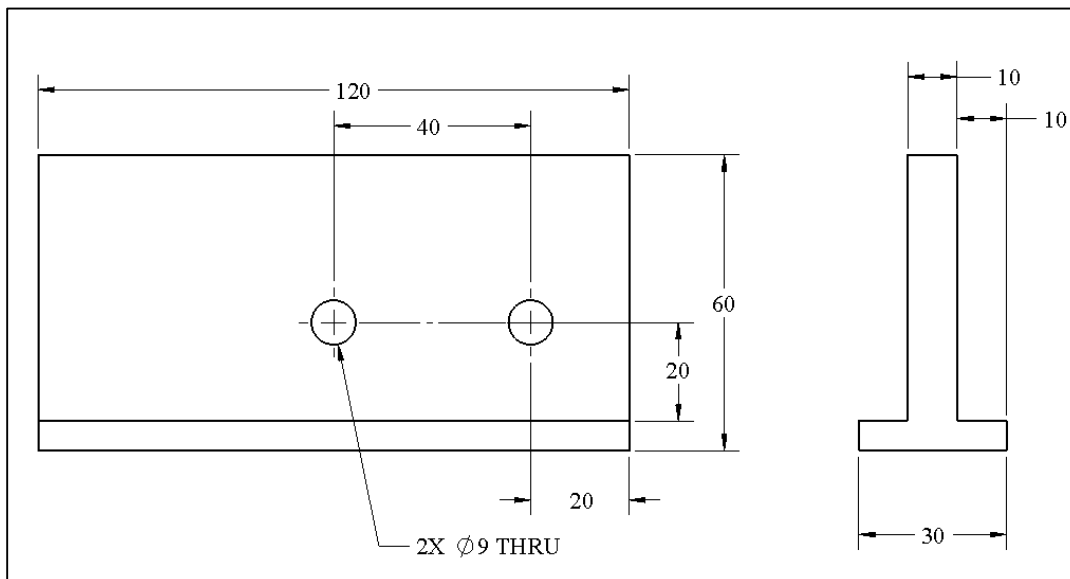
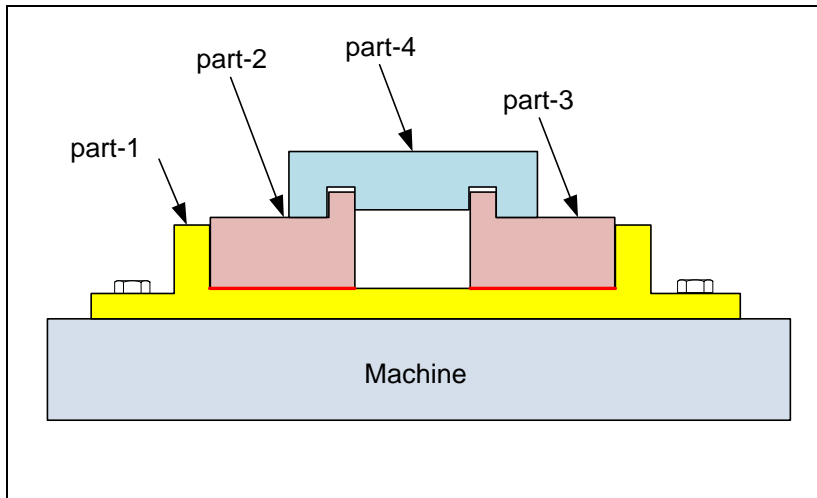


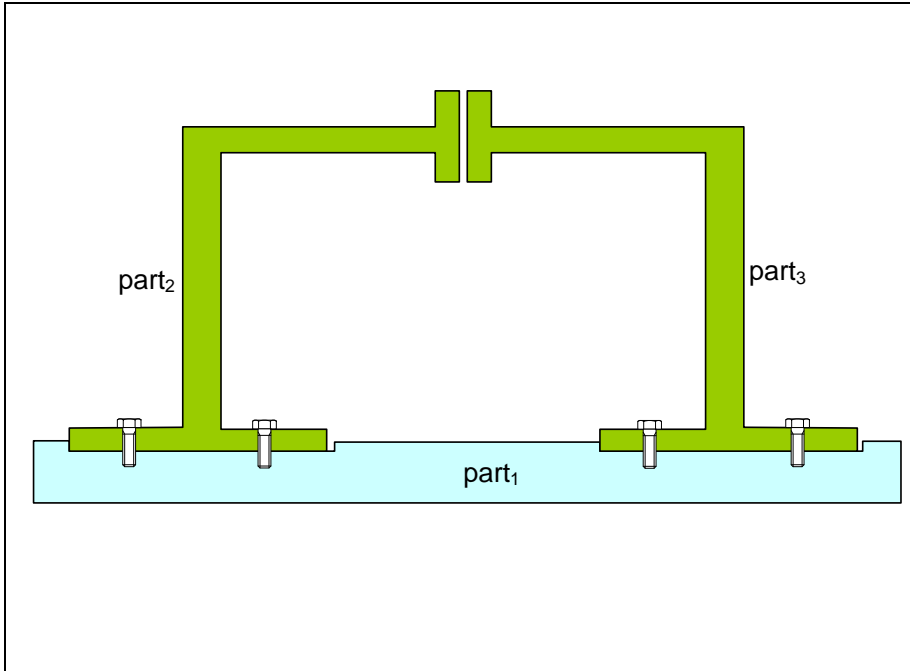
Figure 10-52. Dimensions of the T-shaped part

7. Figure 10-53 shows an attachment of four parts to a machine frame. Tolerance the features of the parts relevant to this four-part fit. Assume part<sub>2</sub> and part<sub>3</sub> are identical and are glued to part<sub>1</sub>. Part<sub>4</sub> is always the last part to be assembled. Set up the theoretical dimensions such that the fit gap between part<sub>4</sub> and part<sub>2</sub> is 1 mm.



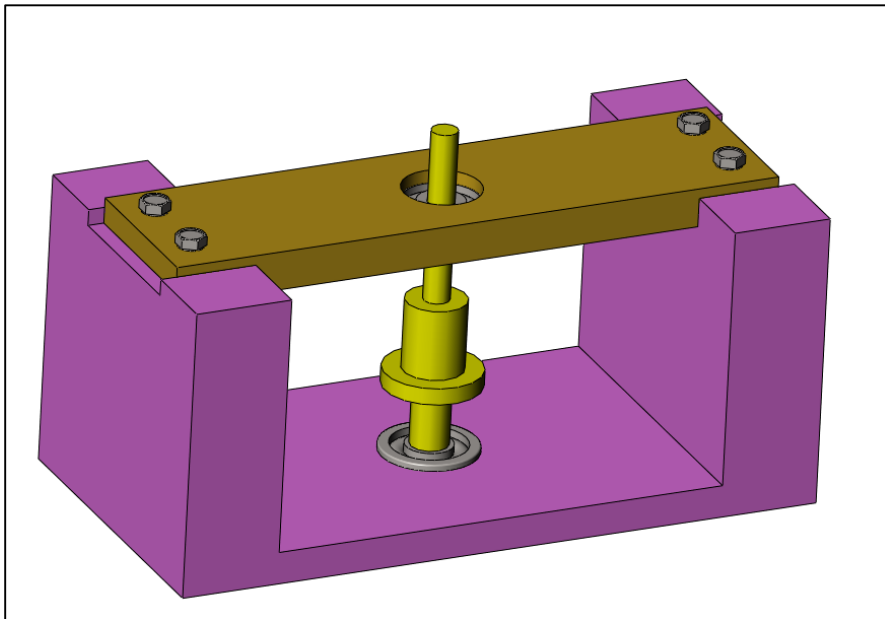
**Figure 10-53. Assembly of four parts**

8. Figure 10-54 shows a three-part assembly. Specify the tolerances necessary to allow a fit between the three parts. Part<sub>2</sub> and part<sub>3</sub> are identical and must have identical specifications. It is not necessary to show the tolerances related to two-part fastener fits.

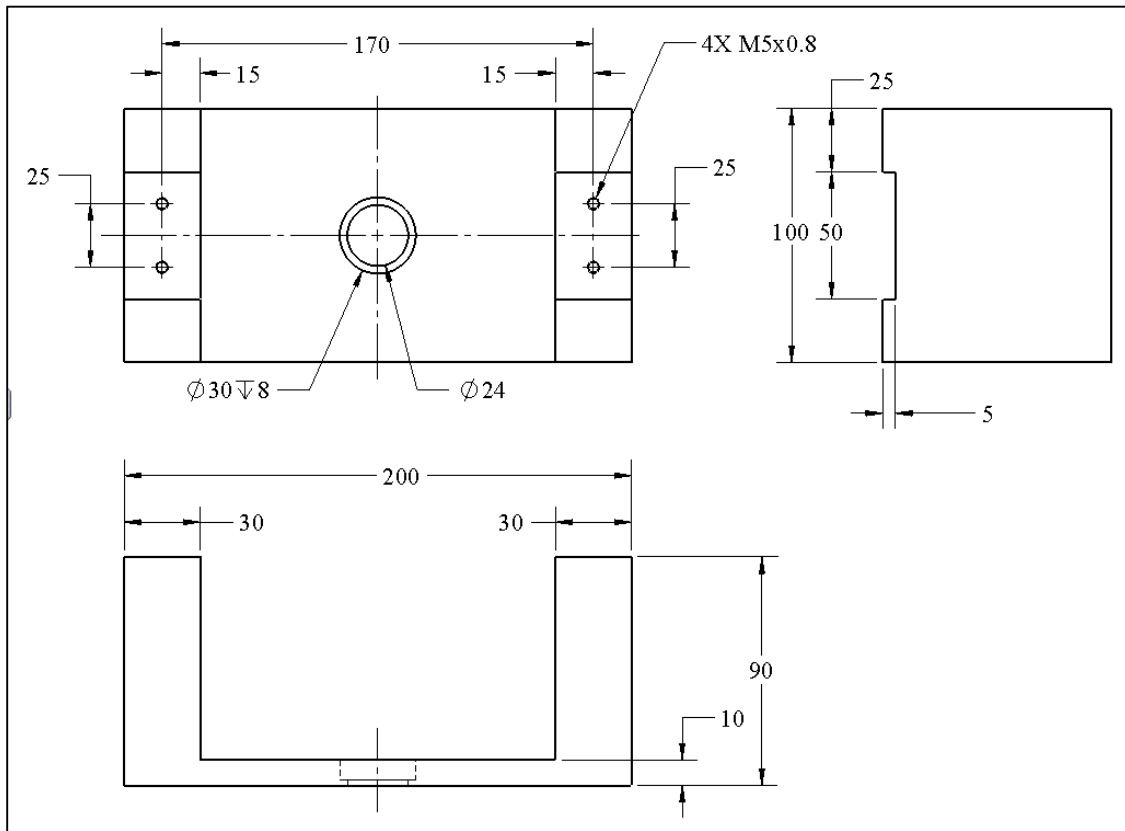


**Figure 10-54. Three-part assembly**

9. Figure 10-55 shows a bearing assembly. Model the assembly and the two parts of the housing using your CAD system and add all the dimensions and tolerances necessary for the proper fit of the parts. Use tolerance values consistent with the machining processes. There is no need to model the bearings or the shaft. Figure 10-56 shows the drawing of the base part with its dimensions.

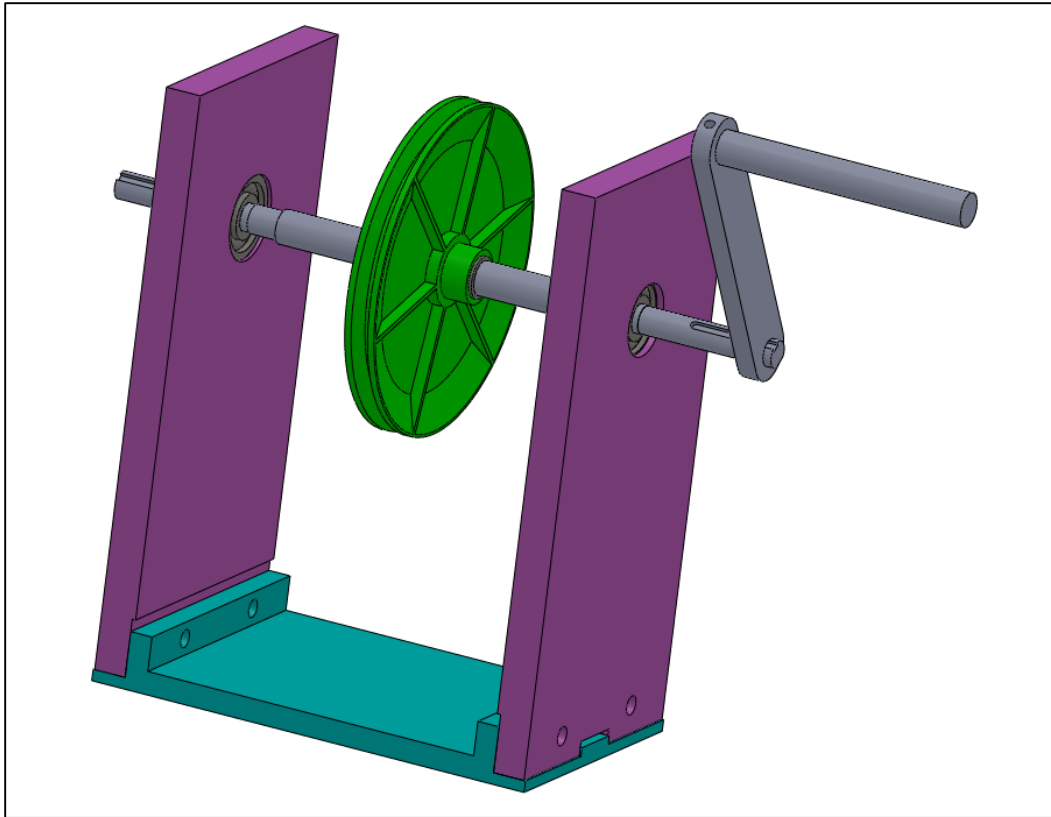


**Figure 10-55. Bearing assembly**



**Figure 10-56. Drawing of the lower part of the housing**

10. Figure 10-57 shows a hand crank assembly. Model the bottom plate and one of the two side plates using your CAD system and add the dimensions and tolerances necessary for the proper fit of the parts. Use tolerance values consistent with the machining processes. There is no need to model the bearings or the shaft.



**Figure 10-57. The hand crank assembly**

Figure 10-58 shows the drawing of the bottom plate with its overall dimensions. The rest of the dimensions are up to you.

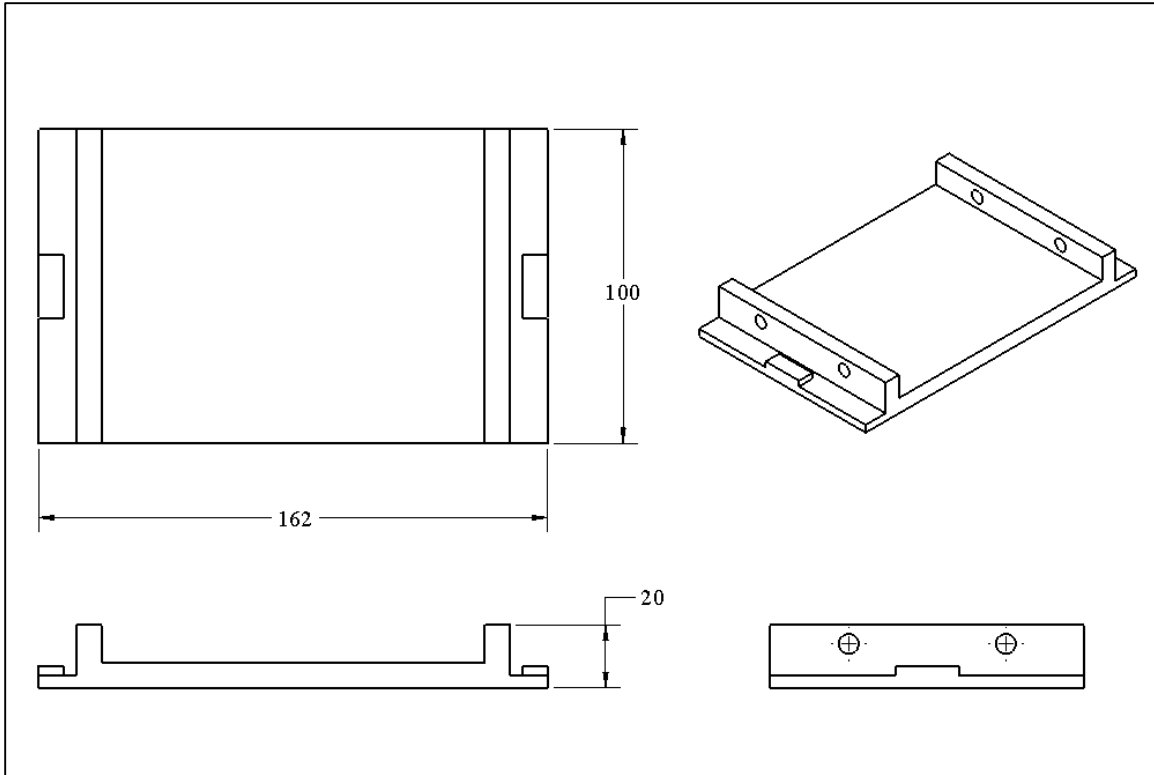


Figure 10-58. The bottom plate of the hand crank assembly

# Chapter 11

## Tolerance Analysis of Multipart Fits

### 11.1. Overview

This chapter introduces tolerance analysis methods for calculating fit clearances in multipart fits. Multipart tolerance analysis can be done graphically with the aid of a CAD system or analytically. In the graphical method, the designer models the parts in a CAD system, puts them together into an assembly, and checks the fit gap. The graphical tolerance analysis method is intuitive and helpful in developing a feel for how changes in dimensions and tolerances influence the fit gap. After becoming more experienced with the graphical analysis method, you can use the quicker analytical method in which the gap value is written as a function of the given dimensions and tolerances. The analytical tolerance method allows a designer to quickly evaluate the consequences of changing the theoretical dimensions or tolerance values on the fit or function of an assembly. The analytical method can also be automated through computer programming. With an effective user interface an analysis program allows a designer to obtain quick and error-free solutions. Such computer programs can also create random simulations of part geometries and allow statistical evaluation of design dimensions and tolerances. The program TAP (Tolerance Analysis Program), which can be downloaded from the book web site, is an example of such a program. To illustrate tolerance analysis methods we will analyze some of the same example assemblies for which the tolerance design task was completed in Chapter-10.

### 11.2. Tolerance analysis overview

Tolerance analysis starts with the selection of a critical assembly dimension whose value depends on the theoretical dimensions and tolerances of other features and other parts. The designer sets acceptable limits for the selected assembly dimension and finds a combination of theoretical dimensions and tolerance values that would meet the selected assembly dimension targets. Most of the problems in tolerancing deal with fit application for which the critical dimension is a gap. The minimum value of the gap is usually set to zero for fit purposes and the resulting maximum value is accepted and left unspecified. The reason a check on maximum gap is usually unnecessary is that when care is exercised to ensure a minimum gap of zero, the maximum gap value becomes just an accumulation of the tolerance values. Usually, an accumulation of a few tolerances does not add up to objectionable values in constrained fits. Sometimes, however, the maximum gap must be controlled with precision for other functional reasons. When the initial tolerance values do not meet the maximum gap requirements, one or more of the following four options can be explored:

1. The design can be changed such that the critical gap is influenced by fewer tolerance values.
2. The design can be changed such that adjustments and alignments can be made during assembly for some fits. For example a design may allow shims to be used

- to adjust distances. Assembly time adjustments reduce the need for high precision features.
3. A degree of risk can be accepted regarding the gap exceeding the acceptable limits in rare cases.
  4. Tolerance values can be reduced.

The first step in tolerance analysis is to determine the dimensions and tolerances that influence the fit gap. In the analytical method, each dimension and each tolerance will be represented by a vector. The size of each vector will correspond to a basic dimension value or a combined dimension and tolerance value. These vectors, along with the gap vector, form a loop called the tolerance loop. The proper identification of the tolerance loop vectors is the most important step in the fit analysis as the rest of the work is mathematical and can be left to a computer program. Tolerance analysis will be illustrated in the context of a variety of problems using both graphical and analytical methods.

### 11.3. Examples

**Example-1: A simple tolerance design problem:** The assembly for Example-1 in Chapter-10 is shown in Figure 11-1. We like to select the theoretical dimensions and tolerance values for a minimum gap of zero.

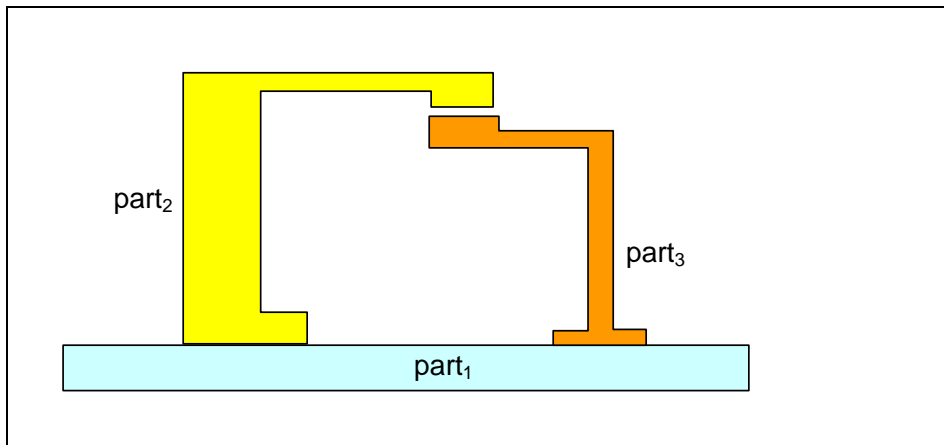


Figure 11-1. An example of a fit involving two dimension values

Figure 11-2 shows the initial selection of theoretical dimensions and tolerance values. While any initial theoretical dimension or tolerance value can be selected, reasonably close values to the final solution are preferred as they provide a degree of error checking.

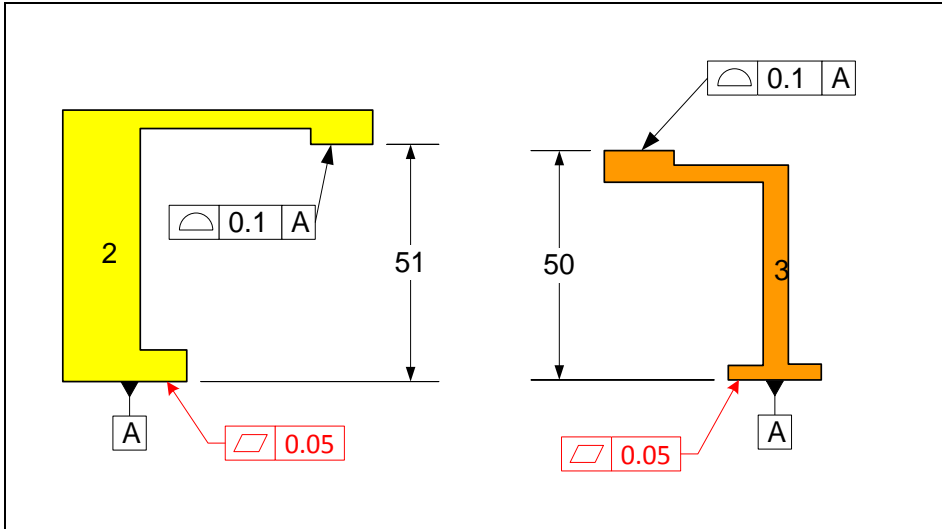


Figure 11-2. Profile tolerances control the fit gap

### Graphical Method

In a CAD system, we can quickly create simple sketches that incorporate the important dimensions and tolerances necessary to find a minimum or maximum gap. The better graphical method approach is to create the 3D solid models of parts and bring them into an assembly. For simple analysis problems, however, we can use the quicker sketch assemblies. Figure 11-3 shows a simple sketch assembly model for this problem. Note that we only need to draw the lines necessary to capture the needed dimensions. The final sketch need not look like the actual design.

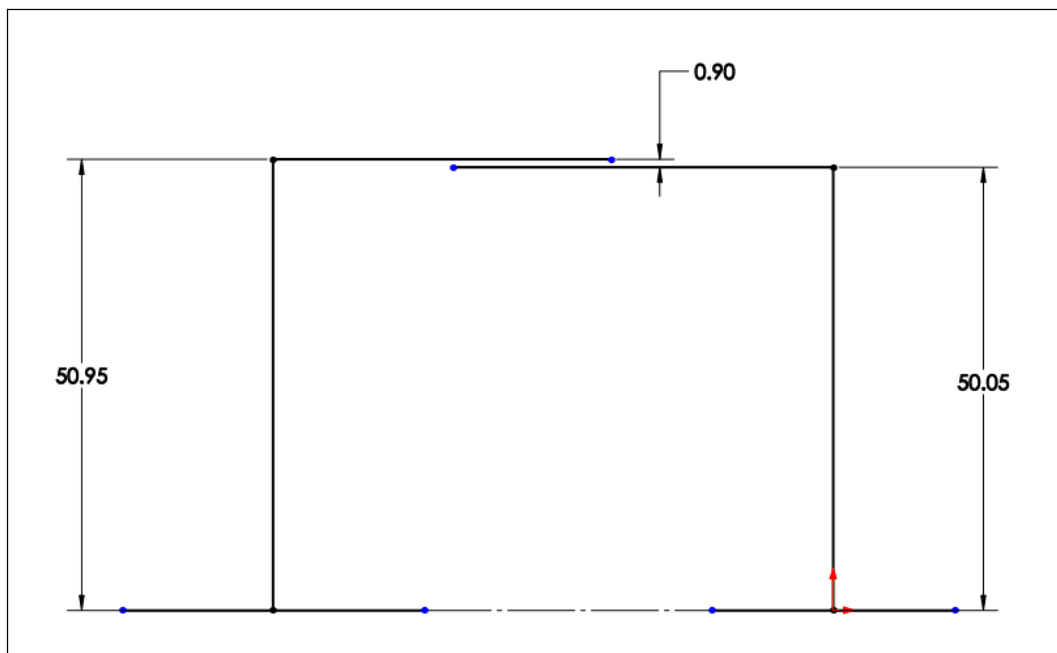
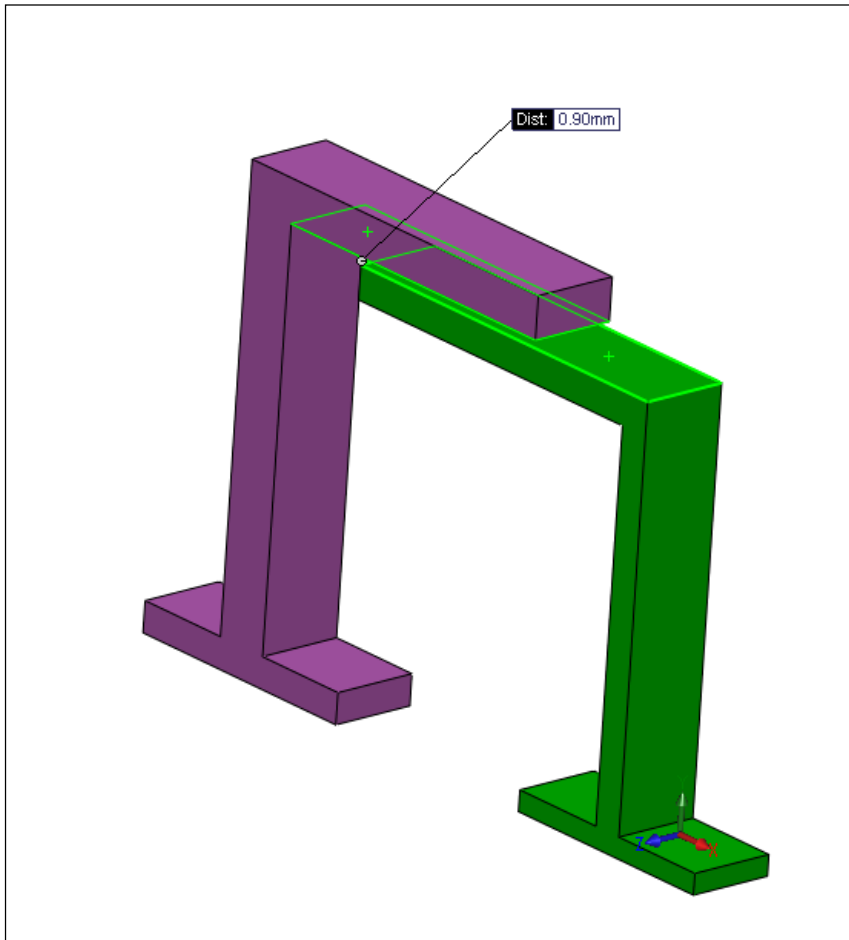


Figure 11-3. CAD sketch model of the assembly

Within the scope of allowed tolerances, the two important dimensions are set to values that lead to the minimum gap. Including the profile tolerances, the smallest dimension on part<sub>2</sub> is 50.95 mm while the largest dimension on part<sub>3</sub> is 50.05 mm. Since the resulting minimum gap is 0.9 mm, we need to change the theoretical value of one of the dimensions by 0.9 mm. For example, we can reduce the 51 mm dimension in part<sub>2</sub> to 50.1 mm. We should then check the gap to make sure it is set to zero as it is not always easy to know the direction in which a dimension influences the gap.

Figure 11-4 shows the 3D solid model of the assembly using the given design dimensions. The 0.90 mm distance is the gap value between the two surfaces.



**Figure 11-4. 3D model of the assembly**

When sketch assemblies become too crowded or confusing the 3D modeling is the best way to avoid errors.

## Analytical Method

Figure 11-5 shows the vectors that influence the gap and form a tolerance loop. Vectors  $A_a$  and  $B_a$  are associated with profile tolerances on single parts and represent the actual distances of the controlled surfaces with respect to their datum planes.

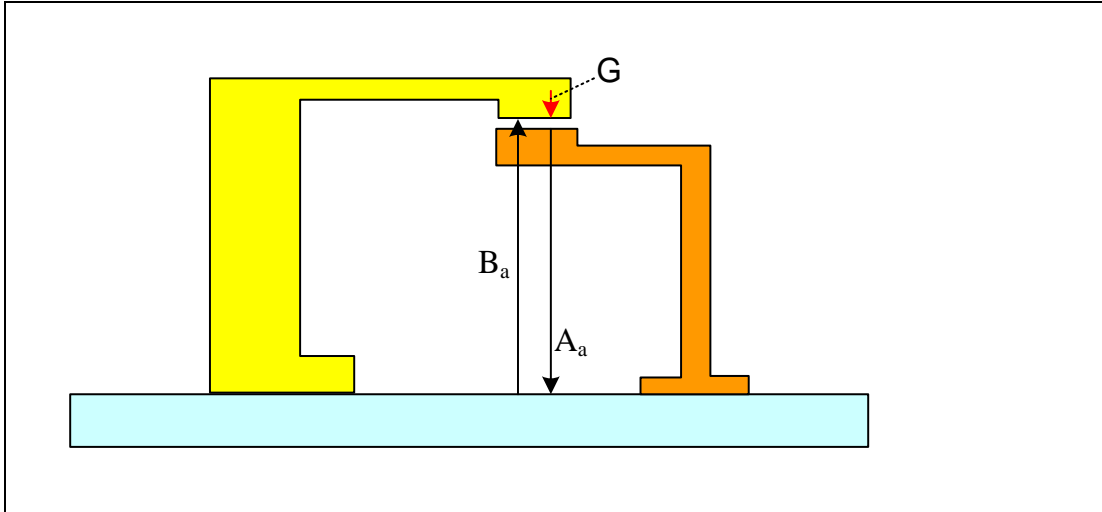


Figure 11-5. Vectors represent variable dimensions controlled by tolerances

We can write an expression for the tolerance loop and the gap vector as

$$G + A_a - B_a = 0 \rightarrow G = B_a - A_a$$

The minimum gap expression is

$$G_{\min} = (B_a)_{\min} - (A_a)_{\max}$$

The value of an actual vector in the tolerance loop can be represented as the sum of a theoretical dimension vector and a deviation vector. In this case, the deviation vector is associated with a profile tolerance

$$A_a = \underline{A} + \delta A$$

And

$$B_a = \underline{B} + \delta B$$

Where  $\underline{A}$  and  $\underline{B}$  are the theoretical dimensions and  $\delta A$  and  $\delta B$  are the deviation vectors.

The deviation vectors can be positive or negative. The gap vector can be written as

$$G = (\underline{B} + \delta B) - (\underline{A} + \delta A)$$

The minimum value of the gap occurs when the deviation vectors assume their largest values. The largest value of the deviation vector is given by half of the profile tolerance value. The minimum gap expression becomes

$$G_{\min} = (\underline{B} - \frac{1}{2} T_B) - (\underline{A} + \frac{1}{2} T_A)$$

Separating the dimensions and tolerances

$$G_{\min} = (\underline{B} - \underline{A}) - (\frac{1}{2} T_A + \frac{1}{2} T_B)$$

The solution procedure in tolerance analysis calls for the initial selection of all tolerance values based on processes believed to have sufficient accuracy for the application. This selection is done during the tolerance design step. In this case, the following tolerance values are selected as shown on the design drawing:

$$T_A = T_B = 0.1 \text{ mm}$$

The tolerance terms add up to

$$\Sigma T = (\frac{1}{2} T_A + \frac{1}{2} T_B) = \frac{1}{2} (0.1 + 0.1) = 0.1 \text{ mm}$$

The initial value of theoretical dimensions term in the loop equation is

$$\Sigma D = (\underline{B} - \underline{A}) = 51 - 50 = 1 \text{ mm}$$

Therefore

$$G_{\min} = \Sigma D - \Sigma T = 1 - 0.1 = 0.9 \text{ mm}$$

As expected the minimum gap for the initial design is 0.9 mm. We like to adjust one of the initial basic dimensions to set the minimum gap to zero. Unless other factors favor a particular selection, the choice of which dimension to adjust is arbitrary. In this case A is accepted with its initial design value of A = 50 and B can be determined from the  $G_{\min}$  equation

$$\Sigma D = G_{\min} + \Sigma T$$

Resulting in

$$\underline{B} - 50 = 0 + 0.1 \rightarrow \underline{B} = 50.1 \text{ mm}$$

The selected theoretical dimensions and tolerances now assure a minimum gap of zero. The result agrees with the graphical solution method. Although usually unnecessary, we can check to see how well these choices do on the maximum gap. In this case:

$$G_{\max} = (\underline{B} - \underline{A}) + \frac{1}{2} (T_A + T_B)$$

Note that when  $G_{\min}$  is zero:

$$(\underline{B} - \underline{A}) = \frac{1}{2} (T_A + T_B)$$

The maximum gap expression becomes

$$G_{\max} = (T_A + T_B)$$

Substituting the numbers results in

$$G_{\max} = (0.1 + 0.1)$$

Or,

$$G_{\max} = 0.2 \text{ mm}$$

Table 11-1 shows the minimum and maximum dimension values associated with profile vectors when the profile tolerance is equally distributed about the theoretical profile. When using the graphical method for minimum or maximum gap check, these values should be used in the modeling of the dimensions.

Vector in gap function	Tolerance Type	Tolerance Value	Minimum value	Maximum value
$A_a$	Profile	T	$\underline{A} - \frac{1}{2} T$	$\underline{A} + \frac{1}{2} T$

**Table-11-1. Dimension limits for vectors associated with a profile tolerance**

Comparing the graphical and the analytical methods we see that in the graphical method the tolerance loop is created implicitly through a geometric construction. In addition, the CAD system performs the additions and subtractions necessary to set the minimum gap to zero to calculate the unknown dimension.

The computer automated version of the analytical method provides a quick and error-free way of tolerance analysis. The procedure involves developing the gap expression and

entering the data for the vector components in the gap expression. For this program the gap expression is

$$G = B_a - A_a$$

Figure 11-6 shows the input and output dialog window of the program. The left-side array of rows is where the user inputs the vector information. This program allows analysis of tolerance loops with up to 10 vectors.

Vector Type	Coefficient	Minimum (L)	Maximum (W)	Tol Type	Tol Value	Qualifier
Profile	1	50.95	51.05	Position	0.1	M
Profile	-1	49.95	50.05	Position	0.1	M
	1	20	21	Position	0.1	M
	1	20	21	Position	0.1	M
	1	20	21	Position	0.1	M
	1	20	21	Position	0.1	M
	1	20	21	Position	0.1	M
	1	20	21	Position	0.1	M
	1	20	21	Position	0.1	M
	1	20	21	Position	0.1	M

Save or Load Model

Save Model Load Model

Example-1

Minimum gap 0.900  
 Maximum gap 1.100

Statistical Analysis

Enter Percentile between 0 and 100 99.9

Min gap 0.905

Max gap 1.095

Calculate

Figure 11-6. The tolerance analysis program dialog screen for Example-1

In this problem, there are two vectors both associated with profile tolerances. The first vector shown in the first row,  $B_a$ , has a +1 coefficient in the gap formula and its initial design specification has a minimum value of 50.95 mm and a maximum value of 51.05 mm. The second vector,  $A_a$ , has a -1 coefficient in the gap formula and has a minimum value of 49.95 mm and a maximum value of 50.05 mm. The data that defines this gap model can be saved in a worksheet, in this case it is saved in Example-1 worksheet. Once saved, a model can be loaded for further analysis at a later time. The right-hand side of the dialog window shows the analysis results. The top part indicates the worst-case minimum and maximum gaps. In this case the minimum gap is 0.9 mm. To reset the minimum gap to zero we can reduce  $B_a$  limits by 0.9 mm to a new range of 50.05 mm to 50.15 mm.

The statistical analysis frame shows the results of twenty thousand random simulations every time the calculate command button is pushed. In each simulation a random value between 50.95 and 51.05 is selected for  $B_a$  variable and a random value between 49.95 and 50.05 is selected for the  $A_a$  variable. All random selections are based on uniform distributions in which any number between the limits is equally likely to be generated. In this case the results show that 99.9% of all the assembly gaps are larger than 0.905 mm and 99.9% of all assembly gaps are smaller than 1.096 mm.

**Example-2: A simple four-part tolerance analysis problem:** The assembly and tolerancing scheme for Example-2 in Chapter-10 is shown in Figures 11-7, 11-8, 11-9, 11-10, and 11-11. We like to select the theoretical dimensions and tolerance values for a minimum gap of zero. In this problem, all fit related dimensions are controlled by profile tolerances except one dimension in part<sub>2</sub> which is controlled by a size tolerance.

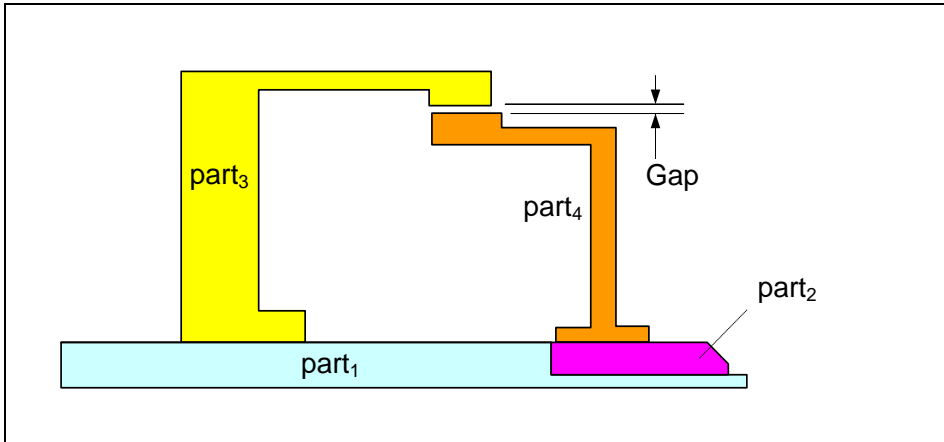


Figure 11-7. An example of a fit involving four parts

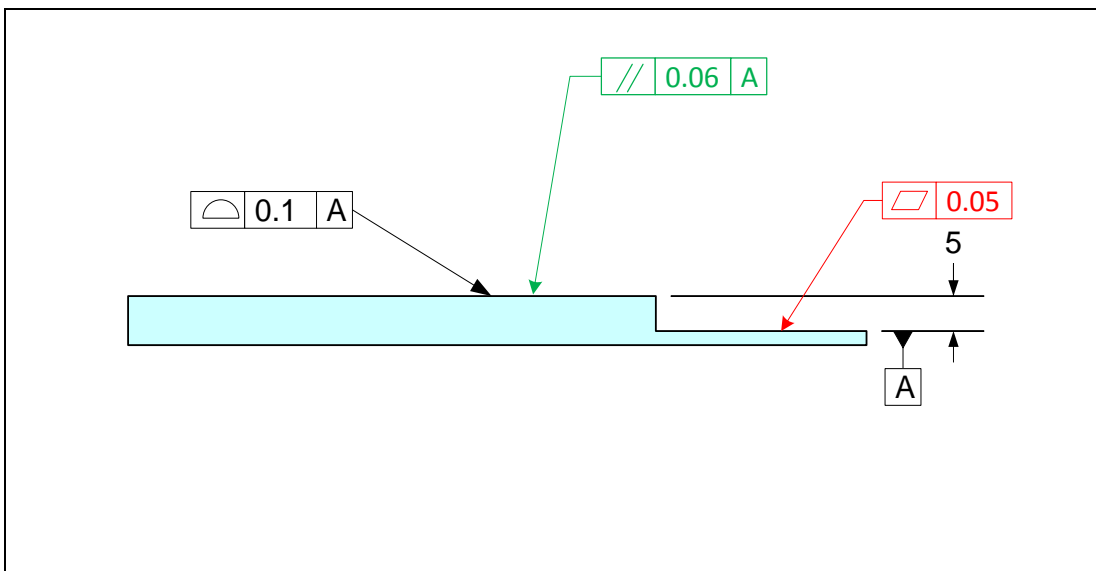


Figure 11-8. Tolerancing of part<sub>1</sub> in the example assembly

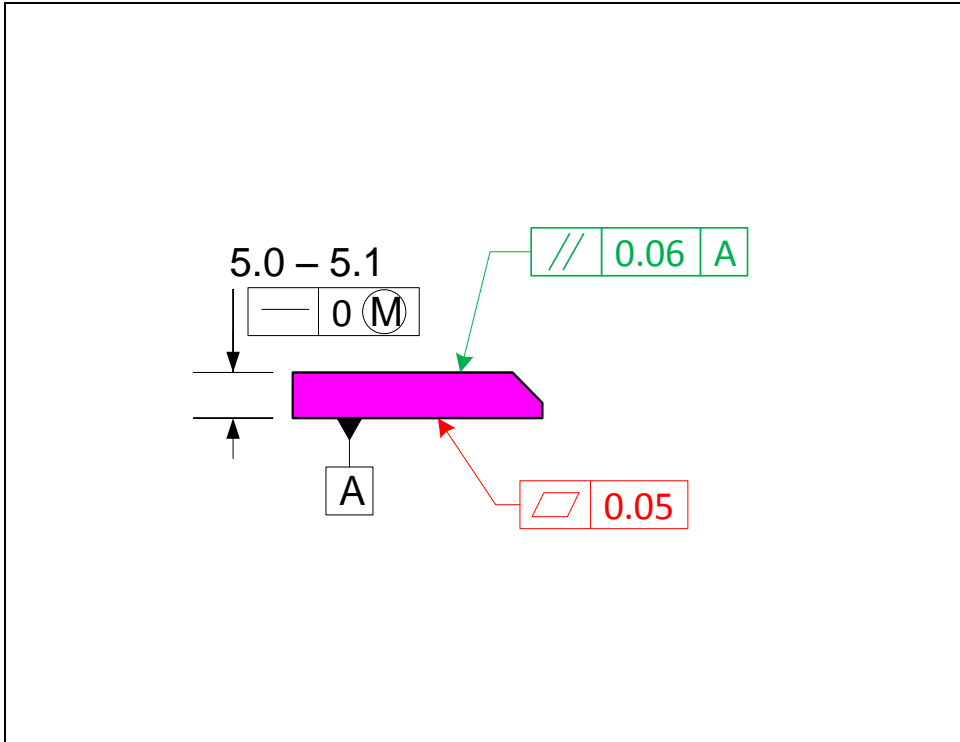


Figure 11-9. Tolerancing of part<sub>2</sub> in the example assembly

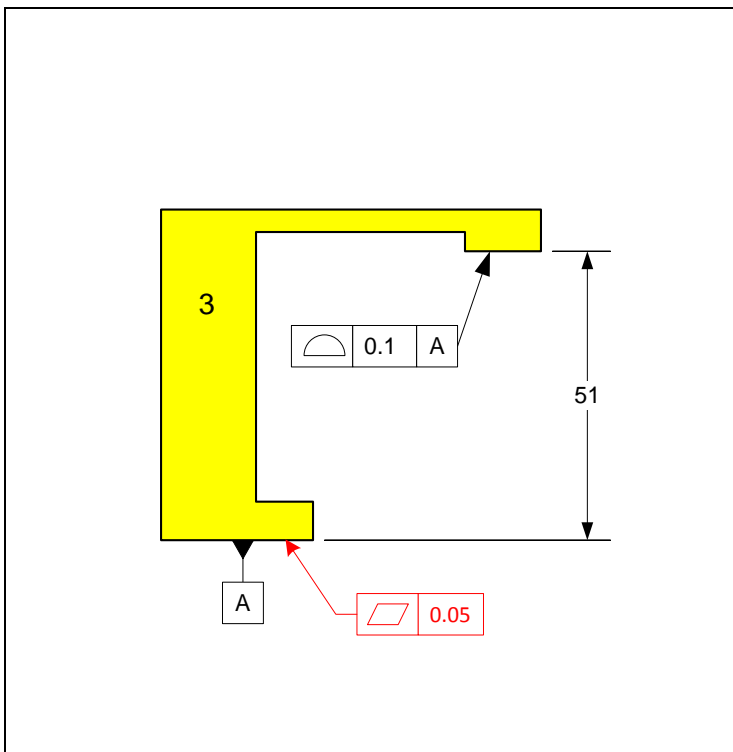


Figure 11-10. Tolerancing of part<sub>3</sub> in the example assembly

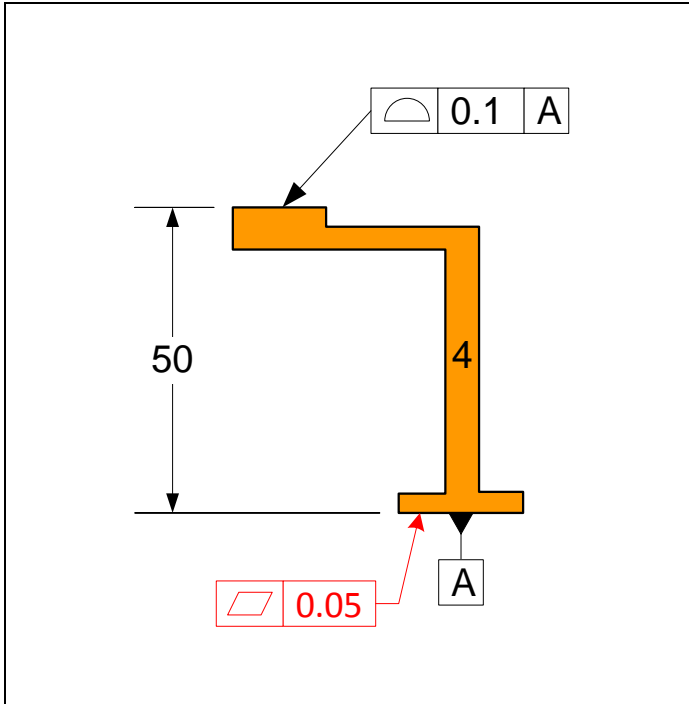


Figure 11-11. Tolerancing of part4 in the example assembly.

### Graphical Method

The tolerance loop for this problem is shown in Figures 11-12. Vector  $G$  represents the gap of interest and other vectors represent the actual dimensions a feature can take given their tolerances. The tolerance loop shows the dimensions that need to be modeled for the fit analysis.

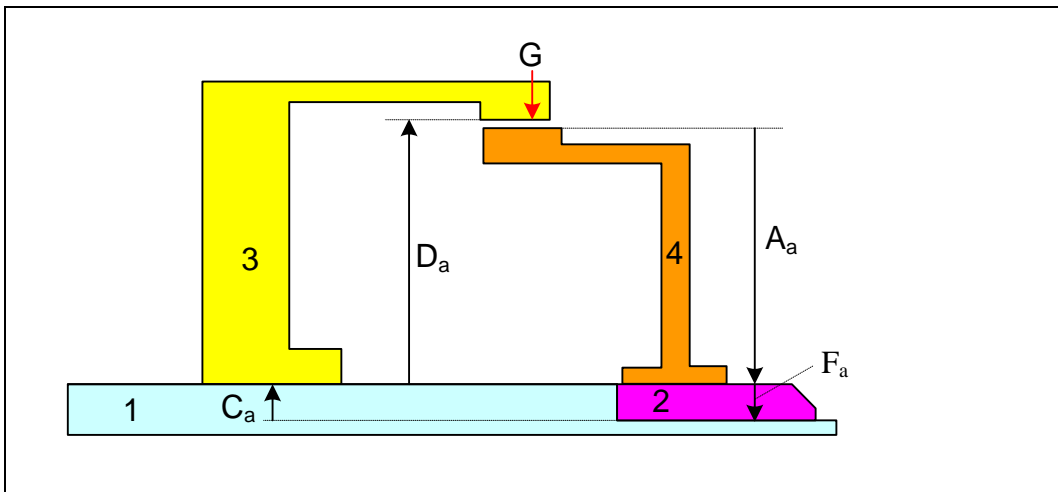


Figure 11-12. Tolerance loop showing the dimensions influencing the gap.

Creating a table of dimension values that leads to the minimum gap helps with the organization of the process. By visualizing how the gap changes when one vector size is changed, we can determine which dimension limit leads to the minimum gap. The following table shows the necessary modeling dimensions and their values for the minimum gap.

Dimension	Part	Initial Values	State
$(C_a)_{\min}$	Part <sub>1</sub>	4.95	-
$(D_a)_{\min}$	Part <sub>3</sub>	50.95	-
$(A_a)_{\max}$	Part <sub>4</sub>	50.05	-
$(F_a)_{\max}$	Part <sub>2</sub>	5.1	MMC

Figure 11-13 shows that the minimum gap based on the initial design dimensions and tolerances is 0.75 mm.

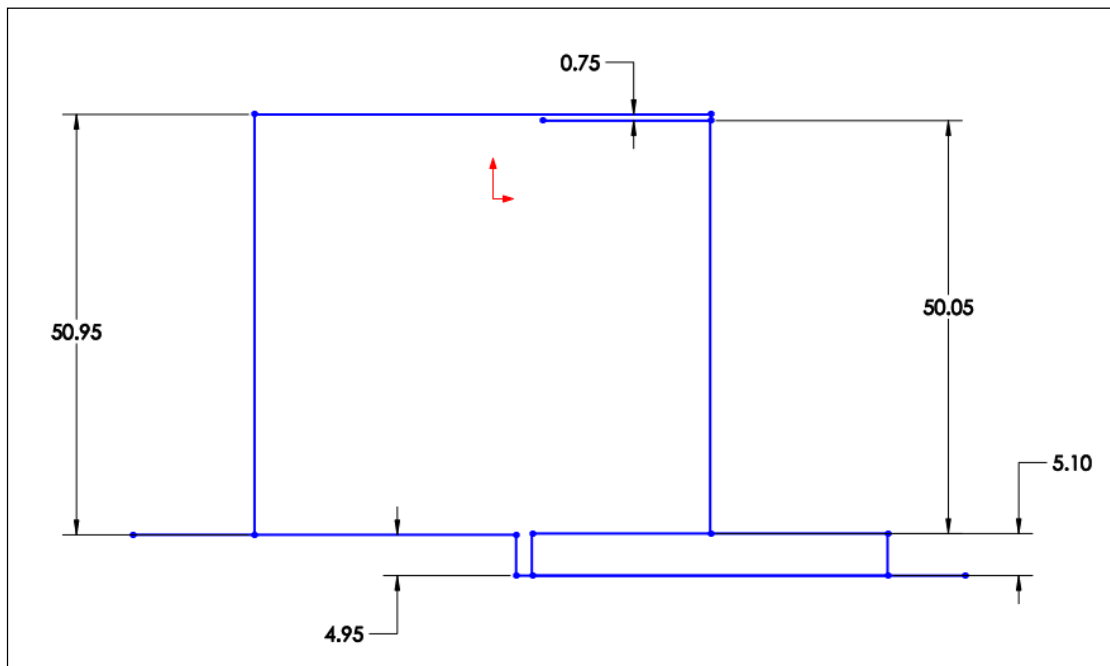


Figure 11-13. CAD sketch model of the assembly

If we choose to adjust the 50.95 mm dimension on part<sub>3</sub> to achieve the zero minimum gap, we need to reduce that value to 50.2 mm. The theoretical 51 mm is subsequently reduced by 0.75 mm to 50.25 mm. To check, we can enter the new 50.2 mm value in the model and evaluate the minimum gap, which should become zero. We can enter the new value in the dimension table to have a record of the new design dimensions as shown in the following table. The shading indicates the value that is altered in order to achieve the zero gap value.

Dimension	Part	Final Values	State
$(C_a)_{\min}$	Part <sub>1</sub>	4.95	-
$(D_a)_{\min}$	Part <sub>3</sub>	50.2	-
$(A_a)_{\max}$	Part <sub>4</sub>	50.05	-
$(F_a)_{\max}$	Part <sub>2</sub>	5.1	MMC

Figure 11-14 shows the 3D solid model of the assembly using the given design dimensions. The 0.75 mm distance is the gap value between the two surfaces.

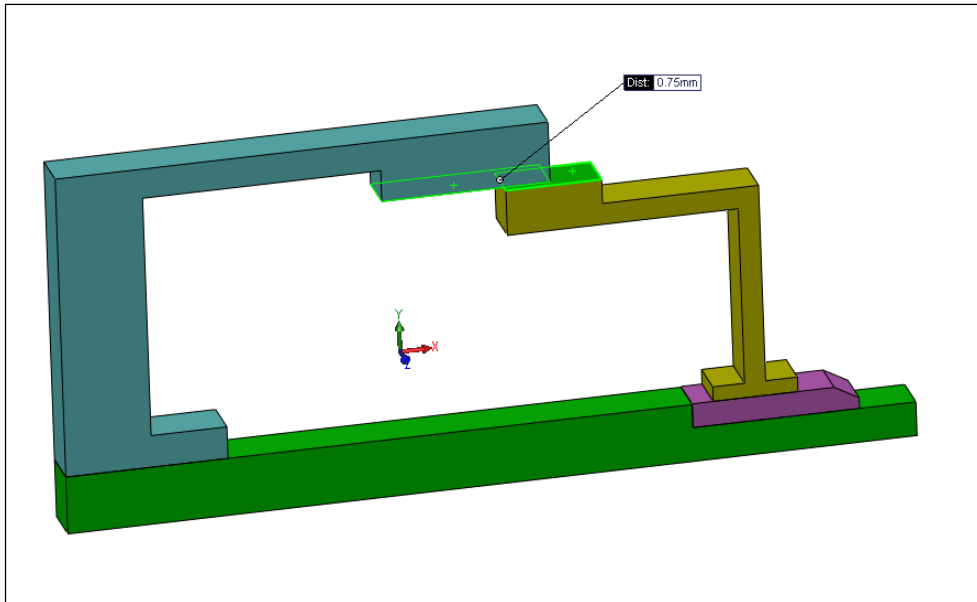


Figure 11-14. 3D model of the assembly

### Analytical Method

Figure 11-15 is the previously shown tolerance loop. Vectors  $A_a$ ,  $B_a$ ,  $C_a$ , and  $D_a$  represent actual dimensions on individual parts while vector  $G$  is between two parts.

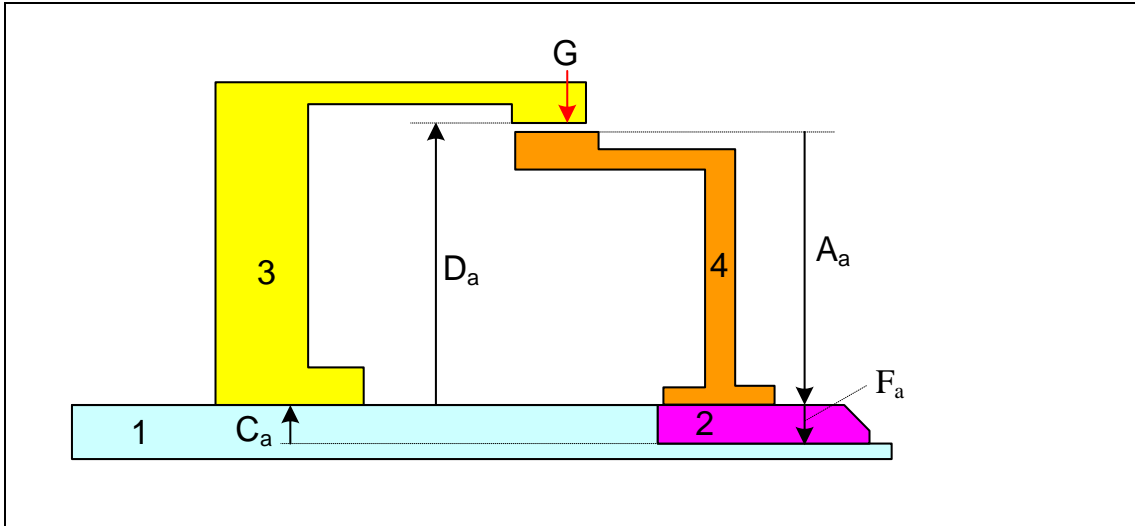


Figure 11-15. Tolerance loop for tolerance analysis

Vectors  $A_a$ ,  $C_a$ , and  $D_a$  are associated with profile tolerances while  $F_a$  is a size dimension. The minimum gap expression is

$$G_{\min} = (C_a)_{\min} + (D_a)_{\min} - (A_a)_{\max} - (F_a)_{\max}$$

We can express  $F_a$  vector as an actual cross-sectional size vector plus a form deviation vector

$$F_a = F_{ac} + \delta_T$$

Where  $F_{ac}$  is the actual cross-section size and  $\delta_T$  is a deviation vector due to the geometric tolerance, in this case flatness. The cross-sectional size limits are the specified LMC and MMC limits, or  $F_{\min}$  and  $F_{\max}$ . The minimum and maximum values for the  $F_a$  vector, when the tolerance is  $\textcircled{M}$  modified are

$$(F_a)_{\min} = F_{\min}$$

$$(F_a)_{\max} = F_{\max} + T_F$$

The minimum value of the gap including the geometric tolerances is

$$G_{\min} = (\underline{C} + \underline{D} - \underline{A}) - F_{\max} - \frac{1}{2}(T_C + T_D + T_A)$$

We can now set the following values based on the initial design

$$\underline{A} = 50$$

$$\underline{B} = \underline{C} = 5$$

$$T_A = T_C = T_D = 0.1 \text{ mm}$$

Setting  $G_{\min} = 0$  and solving for  $\underline{D}$  results in

$$\underline{D} = G_{\min} + (\underline{A} - \underline{C}) + (F_{\max} + T_F) + \frac{1}{2}(T_A + T_C + T_D)$$

Substituting the values

$$\underline{D} = 0 + (50 - 5) + (5.1 + 0) + \frac{1}{2}(0.1 + 0.1 + 0.1) \rightarrow \underline{D} = 50.25 \text{ mm}$$

The solution agrees with the graphical solution. We can also check the resulting maximum gap as

$$G_{\max} = (C_a)_{\max} + (D_a)_{\max} - (A_a)_{\min} - (F_a)_{\min}$$

In calculating the maximum gap, the feature-of-size is assumed to be in its LMC state.

Including the tolerances, the maximum gap is

$$G_{\max} = (\underline{C} + \underline{D} - \underline{A}) - F_{\min} + \frac{1}{2}(T_A + T_C + T_D)$$

Substituting the numbers

$$G_{\max} = (5 + 50.25 - 50) - 5 + \frac{1}{2} (0.1 + 0.1 + 0.1)$$

$$G_{\max} = 0.4 \text{ mm}$$

If this value of  $G_{\max}$  is unacceptable, one or more of the remedies mentioned earlier in this chapter's introduction should be explored.

Figure 11-16 shows the input and output information of the TAP program for this example using the initial design values. The first row is for vector  $C_a$ , the second row is for  $D_a$ , the third row is for  $A_a$ , and the fourth row is for  $F_a$ .

Vector Type	Coefficient	Minimum (L)	Maximum (W)	Tol Type	Tol Value	Qualifier
Profile	1	4.95	5.05	Position	0.1	M
Profile	1	50.95	51.05	Position	0.1	M
Profile	-1	49.95	50.05	Position	0.1	M
Size - External	-1	5.0	5.1	Form/Orient	0	M
	1	20	21	Position	0.1	M
	1	20	21	Position	0.1	M
	1	20	21	Position	0.1	M
	1	20	21	Position	0.1	M
	1	20	21	Position	0.1	M
	1	20	21	Position	0.1	M

Minimum gap 0.750  
 Maximum gap 1.150

**Statistical Analysis**  
 Enter Percentile between 0 and 100: 99.9  
 Min gap: 0.778  
 Max gap: 1.085

Calculate

Save or Load Model  
   
 Example-2

**Figure 11-16. The tolerance analysis program dialog screen for Example-2 with initial values**

To reset the gap to zero we can reduce the second vector limits by 0.75 mm to a range of 50.2 mm to 50.3 mm. The result is shown in Figure 11-17.

Vector Type	Coefficient	Minimum (L)	Maximum (W)	Tol Type	Tol Value	Qualifier
Profile	1	4.95	5.05	Position	0.1	M
Profile	1	50.2	50.3	Position	0.1	M
Profile	-1	49.95	50.05	Position	0.1	M
Size - External	-1	5.0	5.1	Form/Orient	0	M
	1	20	21	Position	0.1	M
	1	20	21	Position	0.1	M
	1	20	21	Position	0.1	M
	1	20	21	Position	0.1	M
	1	20	21	Position	0.1	M
	1	20	21	Position	0.1	M
	1	20	21	Position	0.1	M

Minimum gap 0.000  
 Maximum gap 0.400

Statistical Analysis

Enter Percentile between 0 and 100: 99.9

Min gap: 0.028

Max gap: 0.337

Save or Load Model

Example-2

Figure 11-17. The tolerance analysis program dialog screen for Example-2 with final values

### Example-3: A simple four-part fit with features-of-size

The assembly and tolerancing scheme for Example-3 in Chapter-10 is shown in Figure 11-18 and 11-19. We like to specify the theoretical dimensions and tolerance values for a minimum gap of zero.

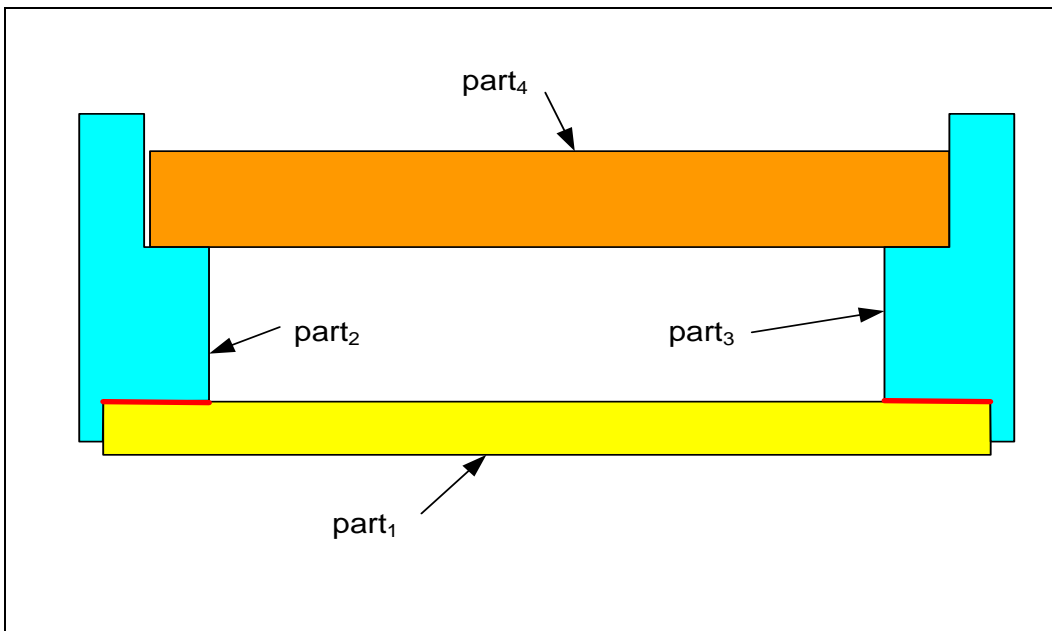


Figure 11-18. A four-part assembly with two fit features

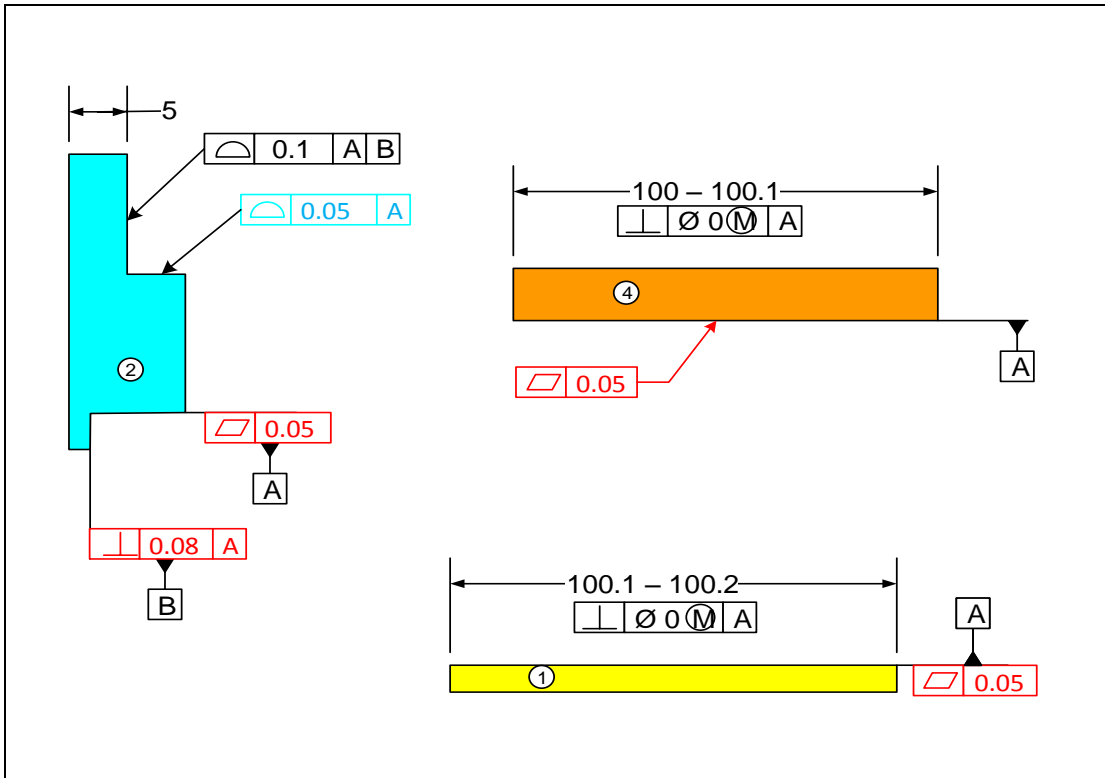


Figure 11-19. The initial assignment of dimensions and tolerances

### Graphical Method

To prepare for the graphical analysis or the analytical analysis, we identify the tolerance loop vectors as shown in Figure 11-20.

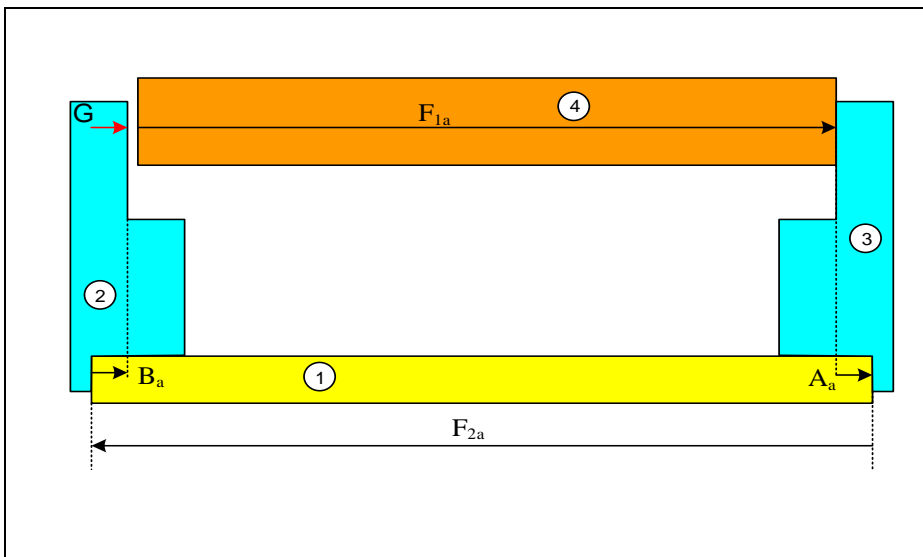
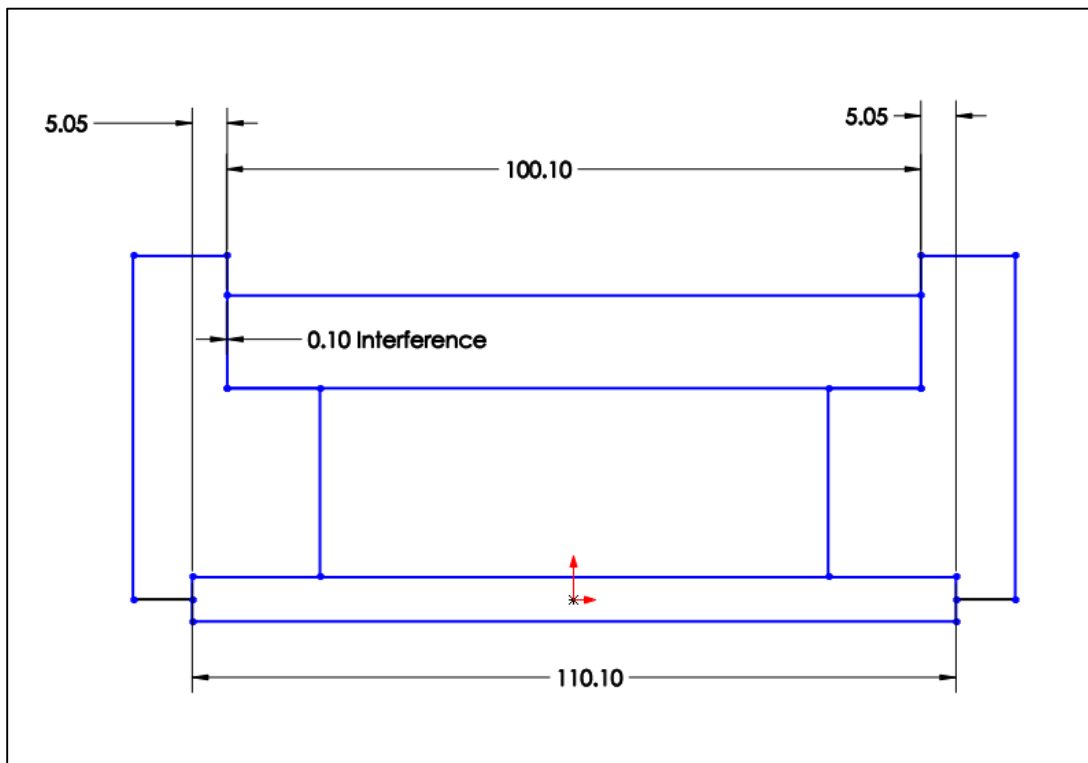


Figure 11-20. Tolerance loop for tolerance analysis

The following table indicates the initial dimension limits used in the graphical modeling of the parts that lead to the minimum gap. For example, if we visualize increasing the  $F_{2a}$  dimension in the figure, the gap will increase. Therefore, we set the  $F_{2a}$  dimension to its minimum value. The table also indicates the final value that leads to a zero minimum gap in parenthesis.

Dimension	Part	Initial Value (Final Value)	State
$(F_{2a})_{\min}$	Part <sub>1</sub>	110.1 (100.2)	LMC
$(F_{1a})_{\max}$	Part <sub>4</sub>	100.1	MMC
$(A_a)_{\max}$	Part <sub>3</sub>	5.05	-
$(B_a)_{\max}$	Part <sub>2</sub>	5.05	-

Figure 11-21 shows the sketch assembly with dimensions as specified in the initial design along with tolerances that lead to the minimum gap. The initial design leads to an interference of 0.1 mm.



**Figure 11-21. CAD sketch model of the assembly for minimum gap**

To set the minimum gap to zero, we need to adjust one of the theoretical dimensions. In this case, we can increase the width limits of part<sub>1</sub> by 0.1 mm to a range of 110.2 – 110.3 mm.

To find the resulting maximum gap we have to set the dimensions and tolerances to values that lead to the maximum gap. The following table indicates the dimension limits to be used in the graphical modeling of the parts that lead to the maximum gap.

Dimension	Part	Modeling Values	State
$(F_{2a})_{\max}$	Part <sub>1</sub>	110.3	MMC
$(F_{1a})_{\min}$	Part <sub>4</sub>	100.0	LMC
$(A_a)_{\min}$	Part <sub>3</sub>	4.95	-
$(B_a)_{\min}$	Part <sub>2</sub>	4.95	-

Figure 11-22 shows the sketch assembly with the dimension values that lead to the maximum gap.

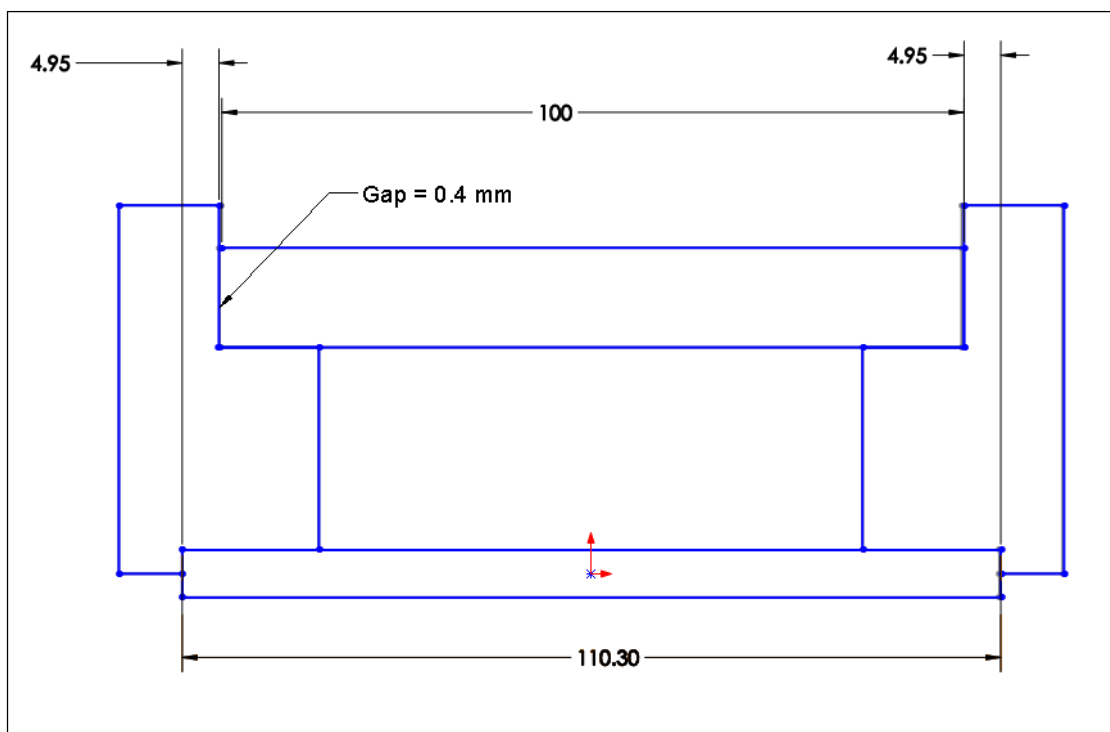


Figure 11-22. CAD sketch model of the assembly for maximum gap

In this case the maximum gap that can result from the specifications is 0.4 mm. Figure 11-23 shows the 3D solid model of the assembly using the initial design dimensions that leads to an interference of 0.1 mm.

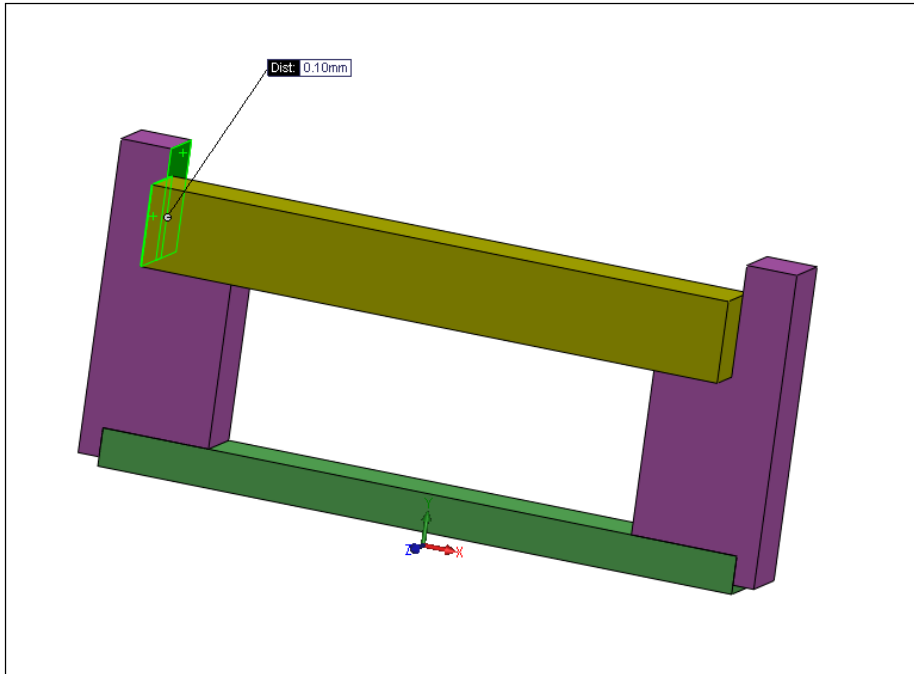


Figure 11-23. 3D model of the assembly

### Analytical Method

To perform the tolerance analysis, we identify the tolerance loop vectors as shown in Figure 11-24.

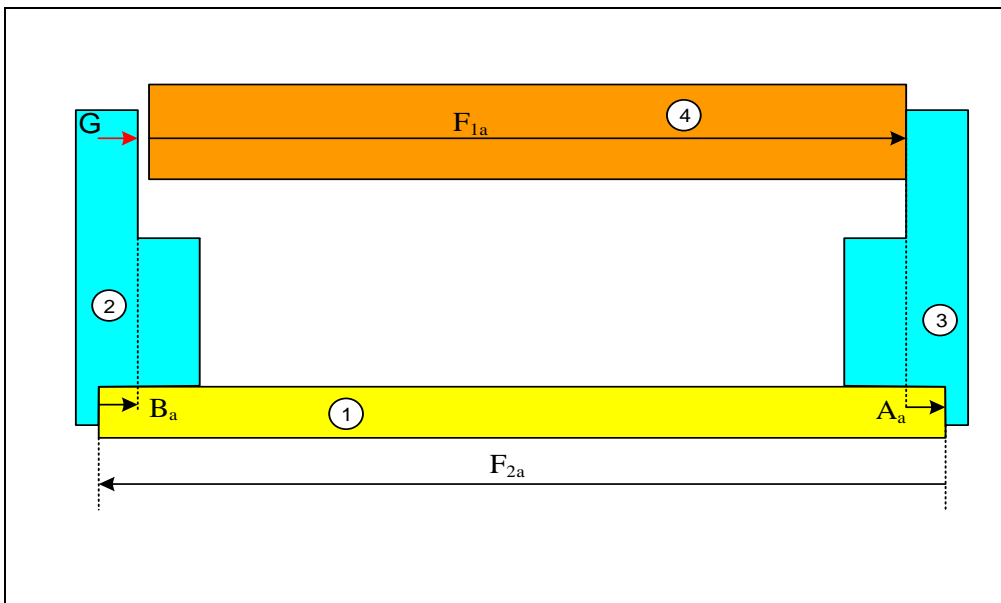


Figure 11-24. Tolerance loop for tolerance analysis

The loop equation is

$$G + F_{1a} + A_a - F_{2a} + B_a = 0 \rightarrow G = F_{2a} - F_{1a} - A_a - B_a$$

The minimum gap expression is

$$G_{\min} = (F_{2a})_{\min} - (F_{1a})_{\max} - (A_a)_{\max} - (B_a)_{\max}$$

$A_a$  and  $B_a$  vectors are associated with profile tolerances.  $F_{1a}$  and  $F_{2a}$  are size vectors associated with orientation tolerances. Including the tolerance vectors, the minimum assembly gap can be expressed as

$$G_{\min} = F_{2\min} - (F_{1\max} + T_{F1}) - (\underline{A} + \frac{1}{2} T_A) - (\underline{B} + \frac{1}{2} T_B)$$

Separating tolerance terms

$$G_{\min} = (F_{2\min} - F_{1\max} - \underline{A} - \underline{B}) - (\frac{1}{2} T_B + T_{F1} + \frac{1}{2} T_A)$$

Initial size tolerances and orientation tolerances are assigned based on the intended processes. In this case we select the following size tolerances

$$t_{F1} = t_{F2} = 0.1$$

Since zero perpendicularity tolerances are used

$$T_{F1} = T_{F2} = 0$$

The profile tolerances are selected to be

$$T_A = T_B = 0.1$$

The following three dimensions are set based on initial design specifications

$$\underline{A} = \underline{B} = 5 \quad F_{1\max} = 100.1$$

Substituting into  $G_{\min} = 0$  we find  $F_{2\min} = 110.2$  mm. Since the size tolerances are 0.1 mm, we can find  $F_{2\max} = 110.3$  mm. The new size limits for the rail features are

$$F_{1\min} = 100.0 \quad F_{1\max} = 100.1$$

$$F_{2\min} = 110.2 \quad F_{2\max} = 110.3$$

This result agrees with the graphical method. We can now check the maximum gap. The  $G_{\max}$  expression is

$$G_{\max} = F_{2\max} - F_{1\min} - (\underline{A} - \frac{1}{2} T_A) - (\underline{B} - \frac{1}{2} T_B)$$

Substituting values for dimensions and tolerances, we get:

$$G_{\max} = 110.3 - 100 - (5 - \frac{1}{2} (0.1)) - (5 - \frac{1}{2} (0.1))$$

$$G_{\max} = 0.4 \text{ mm}$$

When a size vector is associated with a form or orientation tolerance, the form or orientation deviation vector can be combined with the size vector into a fit-equivalent size. Table 11-2 shows the minimum and maximum values of the combined size and geometric deviation vector. These relationships are also used in the graphical modeling for fit-equivalent sizes.

Vector in Gap Function	Tolerance Type	Specified Tolerance	Minimum Value	Maximum Value
$F_a$ (Pin)	Form or Orientation	$T_F @ \textcircled{M}$	$F_{\min}$	$F_{\max} + T_F$
		$T_F$	$F_{\min}$	$F_{\max} + T_F$
		$T_F @ \textcircled{L}$	$F_{\min}$	$F_{\max} + T_F + t_{sF}$
$H_a$ (Hole)		$T_H @ \textcircled{M}$	$H_{\min} - T_H$	$H_{\max}$
		$T_H$	$H_{\min} - T_H$	$H_{\max}$
		$T_H @ \textcircled{L}$	$H_{\min} - T_H - t_{sH}$	$H_{\max}$

**Table-11-2. Dimension limits for vectors associated with a form or orientation tolerances**

For example, if a 20-21 mm pin feature has a perpendicularity tolerance of 0.5 $\text{\textcircled{M}}$ , the specification corresponds to the first row of the table. The minimum value of the combined size and geometric deviation vector for this feature would be its LMC size of 20 mm. The pin's largest combination of size and perpendicularity deviation vector would be the sum of the pin's MMC size and its perpendicularity at MMC, which becomes 21.5 mm.

Figure 11-25 shows the TAP results for the final dimensions that lead to a zero minimum gap.

Vector Type	Coefficient	Minimum (L)	Maximum (W)	Tol Type	Tol Value	Qualifier
Size - External	1	110.2	110.3	Form/Orient	0	M
Size - External	-1	100.0	100.1	Form/Orient	0	M
Profile	-1	4.95	5.05	Position	0.1	M
Profile	-1	4.95	5.05	Form/Orient	0	M
	1	20	21	Position	0.1	M
	1	20	21	Position	0.1	M
	1	20	21	Position	0.1	M
	1	20	21	Position	0.1	M
	1	20	21	Position	0.1	M
	1	20	21	Position	0.1	M
	1	20	21	Position	0.1	M

**Save or Load Model**

Save Model    Load Model

Example-3

**Statistical Analysis**

Enter Percentile between 0 and 100: 99.9

Min gap: 0.053

Max gap: 0.354

Calculate

Figure 11-25. The tolerance analysis program dialog screen for Example-3

#### Example-4: Retaining ring fit on a gearbox shaft

The assembly and tolerancing scheme for Example-4 in Chapter-10 is shown in Figure 11-26. We like to specify the theoretical dimensions and tolerance values for a minimum gap of zero. The maximum gap must not exceed 0.25 mm in order to limit the axial play of the gear.

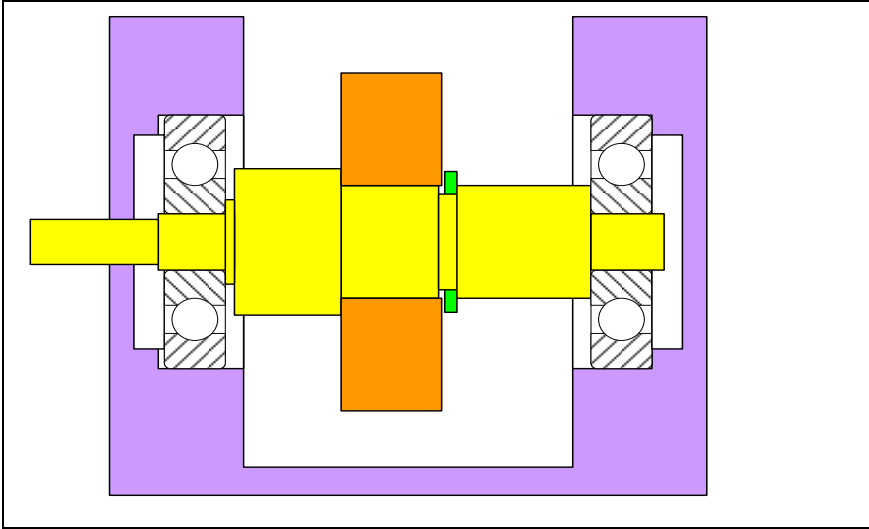


Figure 11-26. A gearbox shaft with a retaining ring fixing the axial location of the gear

The initial dimensions and tolerances that control the gap are shown in Figure 11-27.

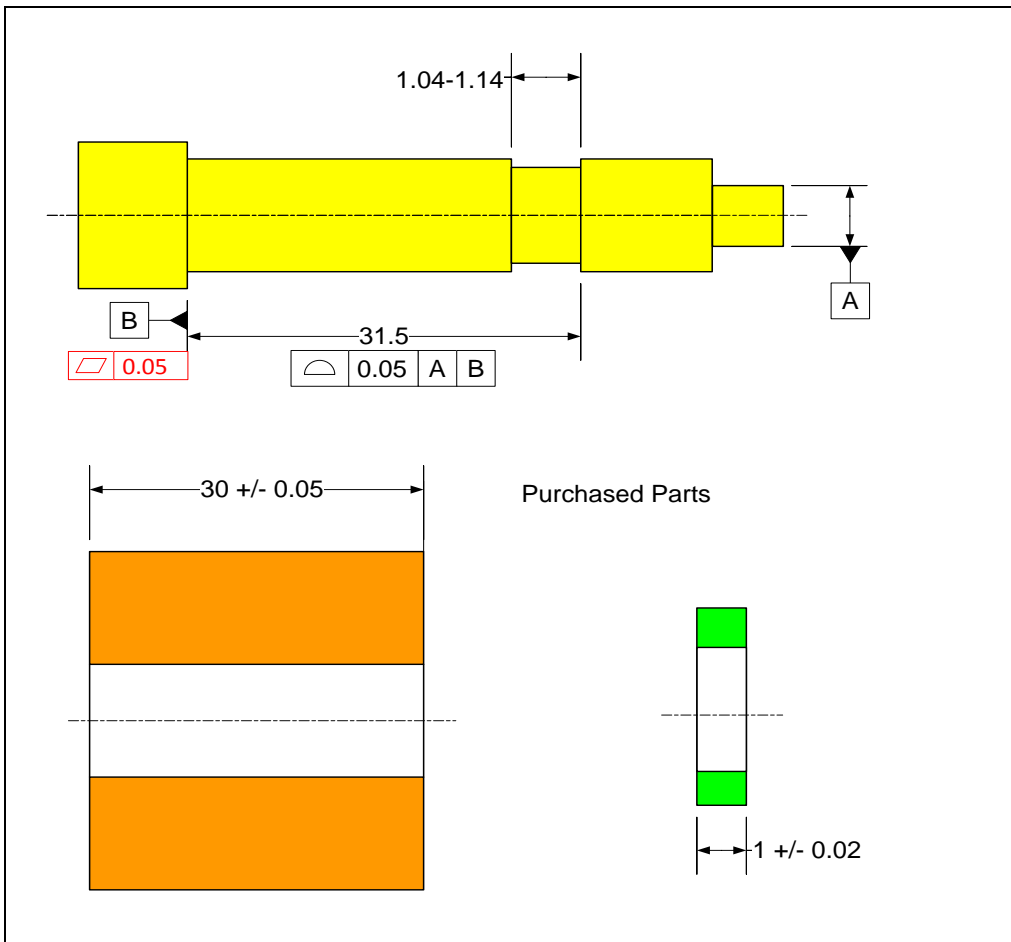


Figure 11-27. The initial assignment of dimensions and tolerances

## Graphical Method

The gap of interest is the distance between the gear face and the retaining ring face. A tolerance loop can be developed incorporating all the relevant features influencing this gap. Figure 11-28 shows the tolerance loop. The  $G$  vector represents the play in the fit.

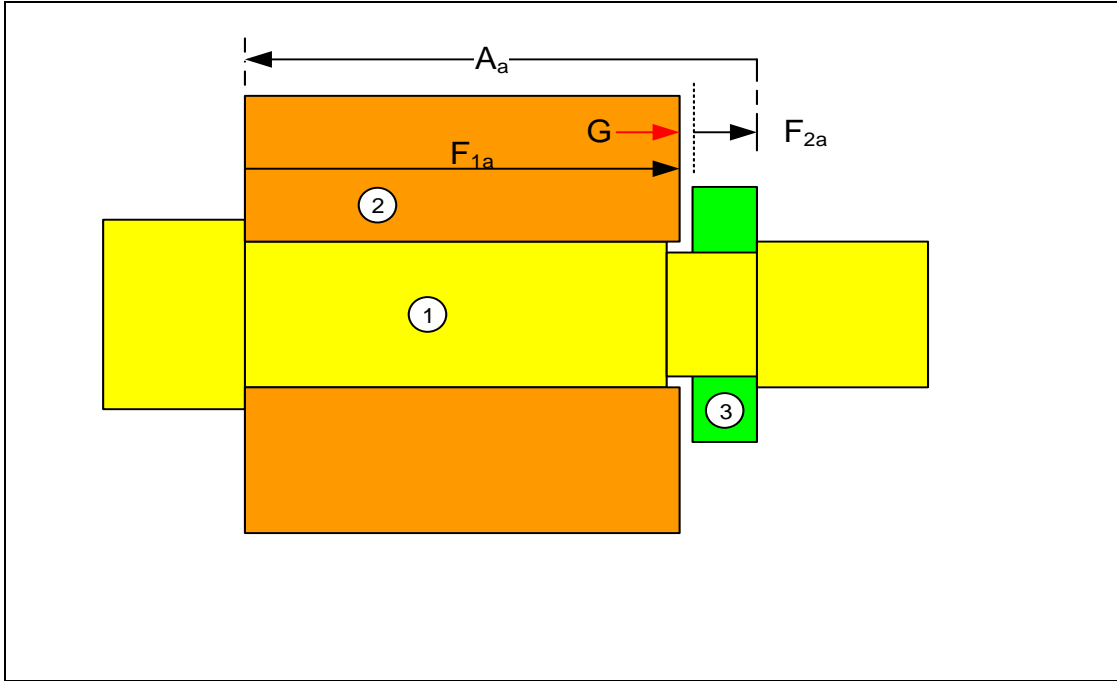
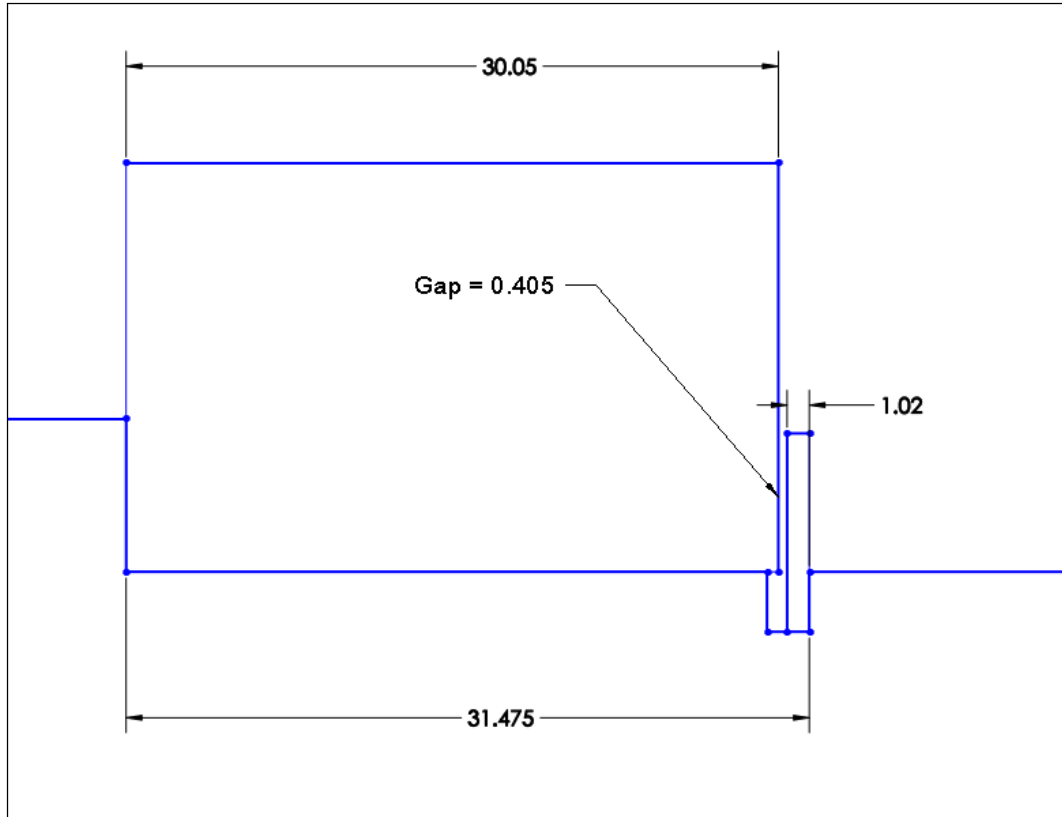


Figure 11-28. The tolerance loop

The following table indicates the initial dimension limits used in the graphical modeling of the parts that lead to the minimum gap. The table also shows the final value of one dimension that leads to a zero minimum gap. The width of the gear is set to its maximum 30.05 mm value and the thickness of the ring is also set to its maximum value of 1.02 mm. The other relevant dimension is the distance associated with the right edge of the groove which is controlled by a profile tolerance. A dimension value of 31.475 mm is used as the minimum distance of the right groove edge relative to the shaft shoulder.

Dimension	Part	Initial Value (Final Value)	State
$(A_a)_{\min}$	Part <sub>1</sub>	31.475 (31.075)	-
$(F_{2a})_{\max}$	Part <sub>3</sub>	1.02	MMC
$(F_{1a})_{\max}$	Part <sub>2</sub>	30.05	MMC

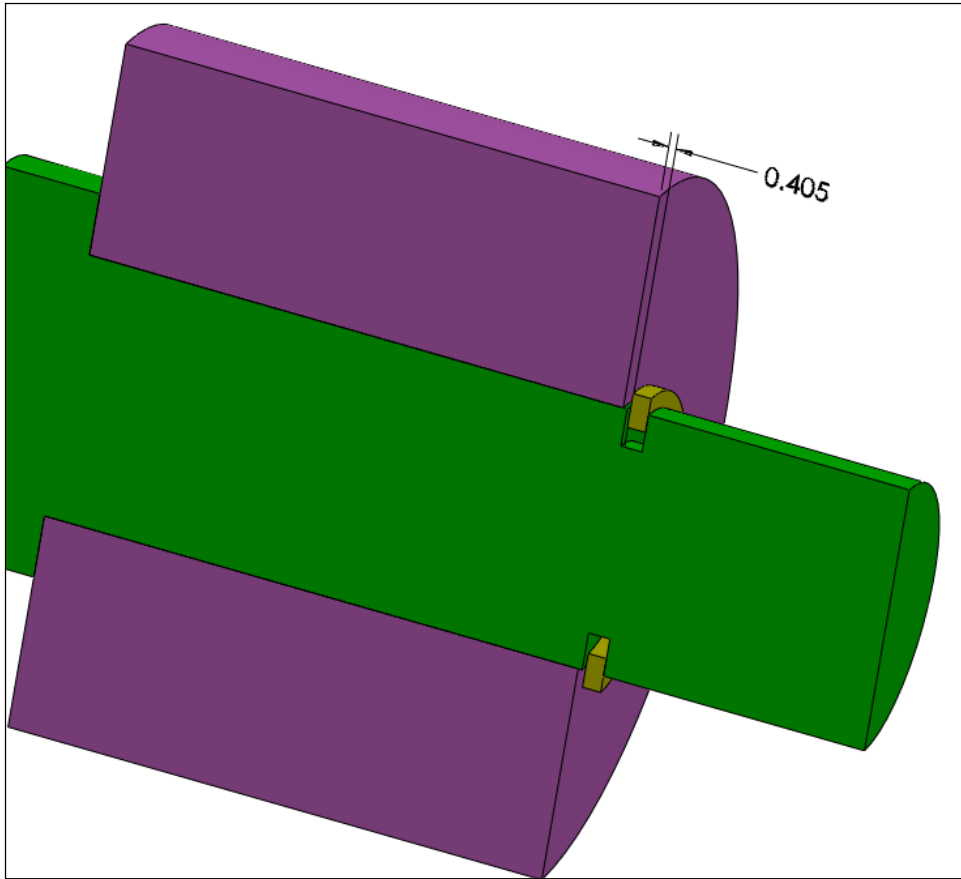
Figure 11-29 shows the relevant parts of the sketch assembly with dimensions resulting in the minimum gap.



**Figure 11-29. CAD sketch model of the assembly**

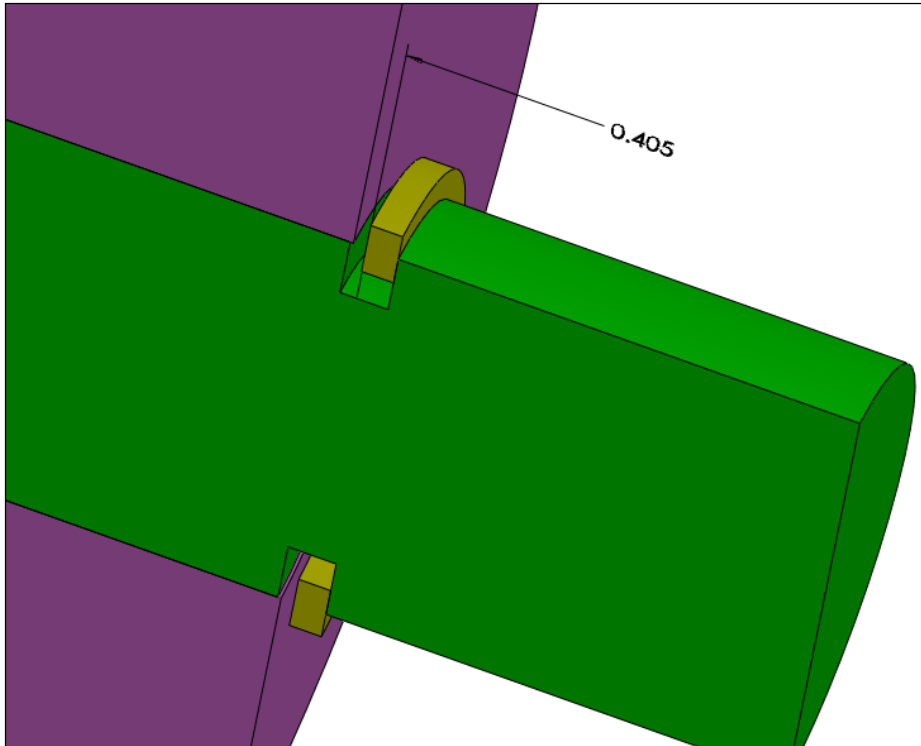
The initial design results in a minimum gap of 0.405 mm. We need to reduce the theoretical distance of the right edge of the groove by 0.405 mm in order to set the minimum gap to zero. This results in  $(A_a)_{\min} = 31.07$  mm and theoretical dimension of  $\underline{A}$  becomes 31.095 mm. We can round up this value to 31.1 mm, allowing a theoretical minimum gap of 0.005 mm. With this new value of  $\underline{A} = 31.1$  mm, the maximum gap can be shown to become 0.195 mm.

Figure 11-30 shows the cutaway of the 3D solid model of the assembly using the initial design dimensions. The 0.405 mm distance is the gap value between the gear and ring surfaces.



**Figure 11-30. 3D model of the assembly**

One of the advantages of the graphical solution is that the designer can check for other problems. In this case the gear width does not go beyond the edge of the groove. This can be corrected by widening the groove by 0.1 mm from 1.43 mm to 1.53 mm. Figure 11-31 shows that the groove size adjustment solves the problem. The minimum and maximum gaps are defined by the faces of the ring and the gear.



**Figure 11-31. 3D model of the assembly after widening the groove size**

This problem is an example of a tolerance analysis problem with multiple assembly variables. In this case both the fit gap and the amount of gear overhang are important. A solution was easy to find for the problem because increasing the width of the groove does not affect the gap value. The right edge of the groove controls the gap and that is controlled directly by the profile tolerance. In other multi-criteria cases, finding a solution based on graphical approach becomes difficult. In the analytical approach we set up a second loop equation for the overhang and solve for the dimension limits and tolerances that satisfies the requirements of both criteria. Multiple criteria problems are formulated just like single criterion problems. They do, however, lead to multiple equations that need to be solved simultaneously.

### **Analytical Method**

Using the tolerance loop a minimum gap expression is developed as

$$G_{\min} = (A_a)_{\min} - (F_{2a})_{\max} - (F_{1a})_{\max}$$

Setting  $G_{\min} = 0$  and solving for  $\underline{A}$  results in

$$0 = (\underline{A} - 0.025) - 1.02 - 30.05$$

$$\underline{A} = 31.095 \text{ mm}$$

This value can be kept as a theoretical dimension or, accepting a minimum gap of 0.005 mm, it can be rounded up to

$$\underline{A} = 31.1 \text{ mm}$$

The maximum gap expression is

$$G_{\max} = (A_a)_{\max} - (F_{2a})_{\min} - (F_{1a})_{\min}$$

Substituting the values we get

$$G_{\max} = 31.225 - 0.98 - 29.95$$

$$G_{\max} = 0.295 \text{ mm}$$

As an exercise, you can set up the loop equation for the overhang and determine the overhang limits based on  $\underline{A} = 31.1$  mm solution and groove size limits of 1.43 to 1.53 mm. Is the overhang value positive?

Figure 11-32 shows the TAP results for the final dimensions that lead to a zero minimum gap.

Vector Type	Coefficient	Minimum (L)	Maximum (W)	Tol Type	Tol Value	Qualifier
Profile	1	31.075	31.225	Form/Orient	0	M
Size - External	-1	0.98	1.02	Form/Orient	0	M
Size - External	-1	29.95	30.05	Form/Orient	0	M
	-1	4.95	5.05	Form/Orient	0	M
	1	20	21	Position	0.1	M
	1	20	21	Position	0.1	M
	1	20	21	Position	0.1	M
	1	20	21	Position	0.1	M
	1	20	21	Position	0.1	M
	1	20	21	Position	0.1	M

Minimum gap 0.005

Maximum gap 0.295

**Statistical Analysis**

Enter Percentile between 0 and 100: 99.0

Min gap: 0.020

Max gap: 0.224

Calculate

**Save or Load Model**

Save Model Load Model

Example-4

**Figure 11-32. The tolerance analysis program dialog screen for Example-4**

The statistical results show that 99% of assemblies will have a gap greater than 0.02 mm and 99% of assemblies will have a gap less than 0.224 mm.

### Example-5: Thermal expansion gap of a gearbox shaft

The assembly for Example-5 in Chapter-10 is shown in Figure 11-33. The figure also shows the tolerance loop. We like to set up the theoretical dimensions and tolerance values for a minimum gap of 0.25 mm. The maximum gap must not exceed 0.7 mm. This problem will only be solved using the analytical method.

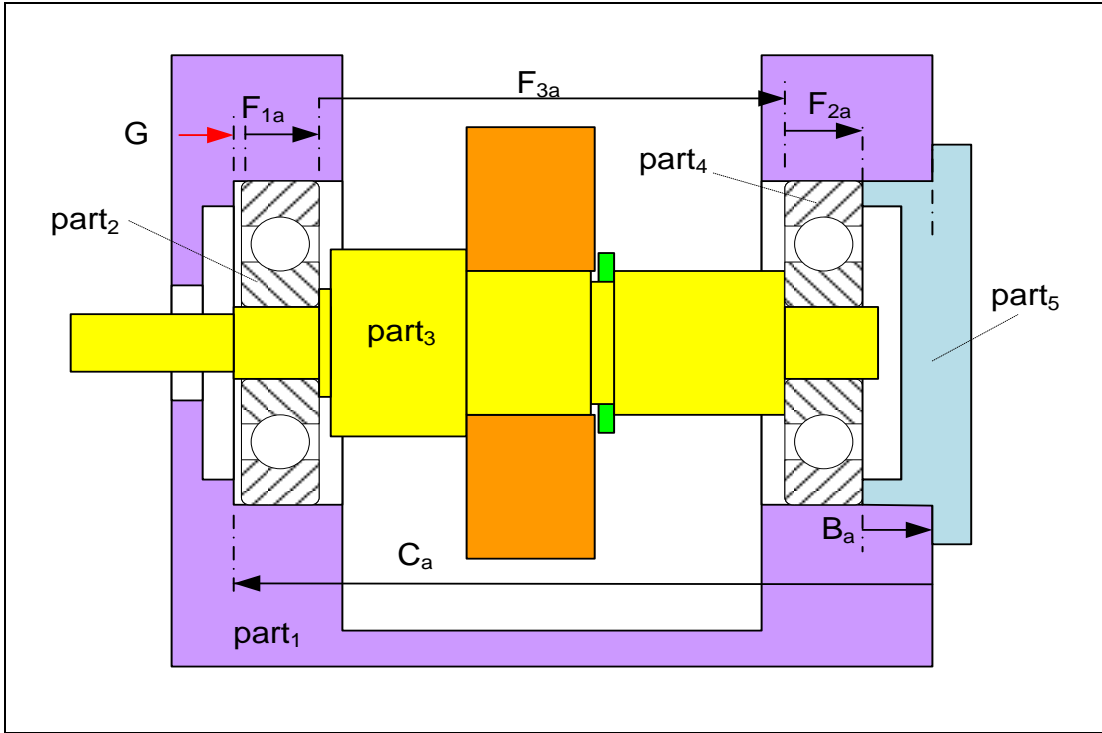


Figure 11-33. The gap dimension in this gearbox depend on six part dimensions

The loop equation is

$$G + F_{1a} + F_{3a} + F_{2a} + B_a - C_a = 0$$

$G_{\min}$  expression becomes

$$G_{\min} = (C_a)_{\min} - (F_{1a})_{\max} - (F_{2a})_{\max} - (F_{3a})_{\max} - (B_a)_{\max}$$

Adding the tolerance vectors

$$G_{\min} = (\underline{C} - \frac{1}{2} T_C) - F_{1\max} - F_{2\max} - F_{3\max} - (\underline{B} + \frac{1}{2} T_B)$$

We can solve for  $\underline{B}$  dimension

$$\underline{B} = (\underline{C} - \frac{1}{2} T_C) - F_{1\max} - F_{2\max} - F_{3\max} - \frac{1}{2} T_B - G_{\min}$$

The initial tolerance specifications for custom parts are shown in Figure 11-34. The standard bearing width size limits are 9.95 – 10.00 mm.

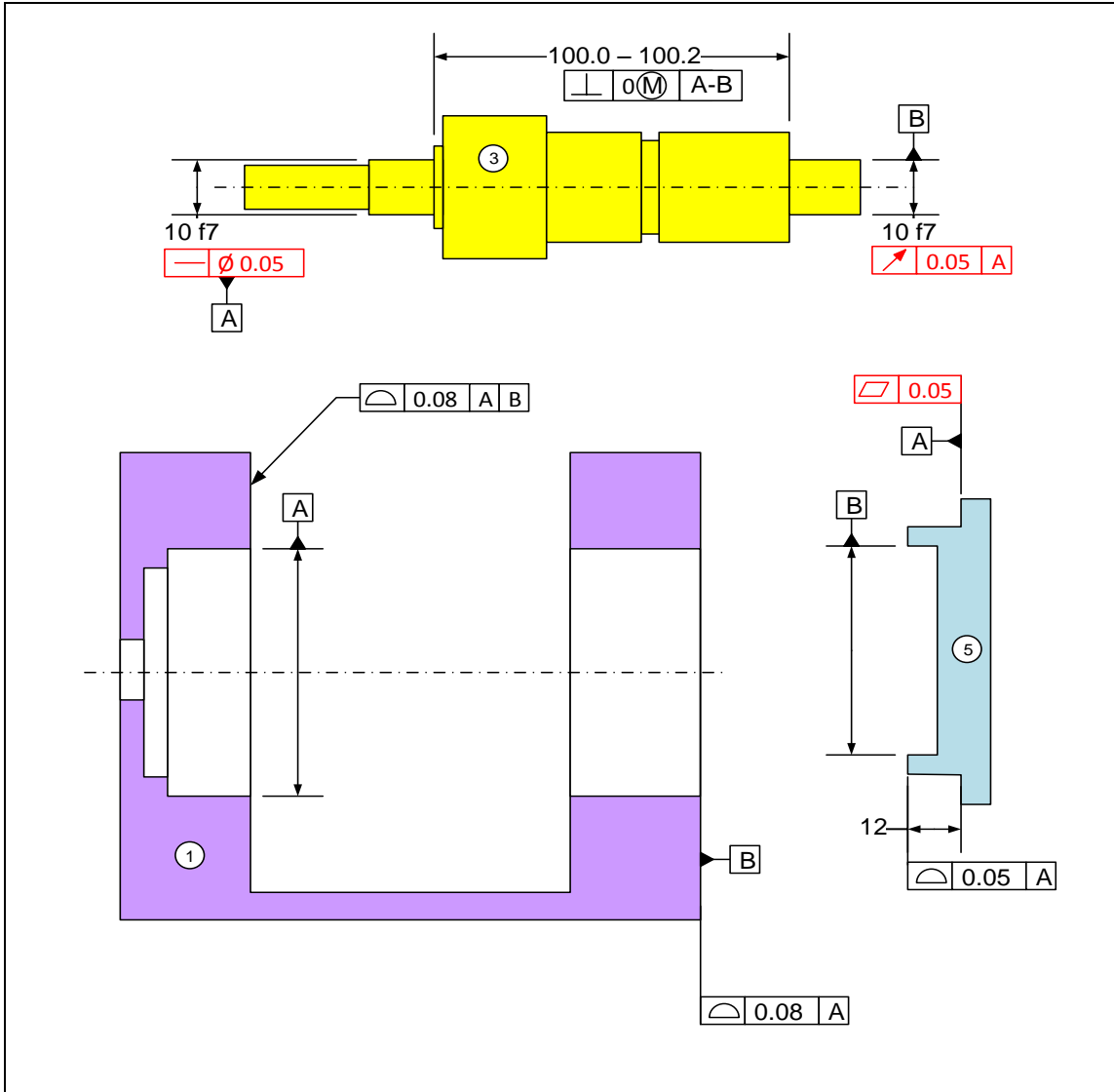


Figure 11-34. The initial assignment of tolerances

Substituting the numbers

$$\underline{B} = (132 - 0.04) - 10 - 100.2 - 10 - 0.04 - 0.25$$

or

$$\underline{B} = 11.47 \text{ mm}$$

We need to change the theoretical  $\underline{B}$  dimension from the initial 12 mm to the new 11.47 mm value for a minimum gap of 0.25 mm. Checking for  $G_{\max}$  we get

$$G_{\max} = (C_a)_{\max} - (F_{1a})_{\min} - (F_{2a})_{\min} - (F_{3a})_{\min} - (B_a)_{\min}$$

$$G_{\max} = 132.04 - 9.95 - 9.95 - 100 - (11.47 - 0.04)$$

Leading to

$$G_{\max} = 0.71 \text{ mm}$$

The maximum gap is just over the maximum acceptable 0.7 mm. Options to remedy this situation can be one or more of the following:

- Accept the slight risk of the gap exceeding 0.7 mm and accept the solution.
- Slightly reduce some size or profile tolerances and solve for new B.
- Set up the minimum gap to a value slightly smaller than 0.25 mm.

Figure 11-35 shows the TAP results for the final dimensions that lead to 0.25 mm minimum gap. Note that if each deviation follows a uniform random distribution pattern within a range defined by tolerances, 99.9% of all the assemblies would have a maximum gap of less than 0.6 mm.

Vector Type	Coefficient	Minimum (L)	Maximum (W)	Tol Type	Tol Value	Qualifier
Profile	1	131.96	132.04	Form/Orient	0	M
Size - External	-1	9.95	10.0	Form/Orient	0	M
Size - External	-1	9.95	10.0	Form/Orient	0	M
Size - External	-1	100.0	100.2	Form/Orient	0	M
Profile	-1	11.43	11.51	Position	0.1	M
	1	20	21	Position	0.1	M
	1	20	21	Position	0.1	M
	1	20	21	Position	0.1	M
	1	20	21	Position	0.1	M
	1	20	21	Position	0.1	M
	1	20	21	Position	0.1	M

**Statistical Analysis**

Enter Percentile between 0 and 100:

Min gap:

Max gap:

Save or Load Model

Figure 11-35. The tolerance analysis program dialog screen for Example-5

### Example-6: A multipart tolerance design with loose fit features

The assembly of Example-6 in Chapter-10 and the initial tolerance assignments are shown in Figure 11-36 and 11-37 and 11-38. In this problem we have a vector that is associated with a position tolerance. We like to adjust one of the theoretical dimensions to obtain a zero minimum gap with the given tolerances.

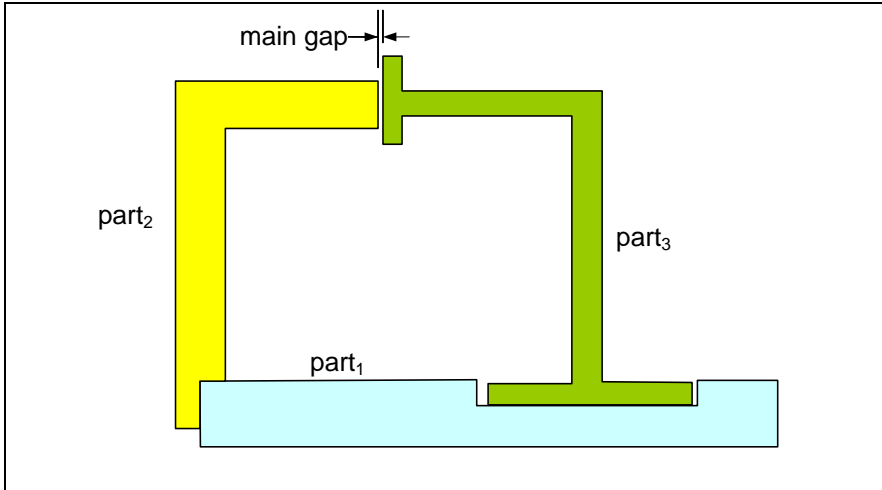


Figure 11-36. A multipart assembly with loose fit features

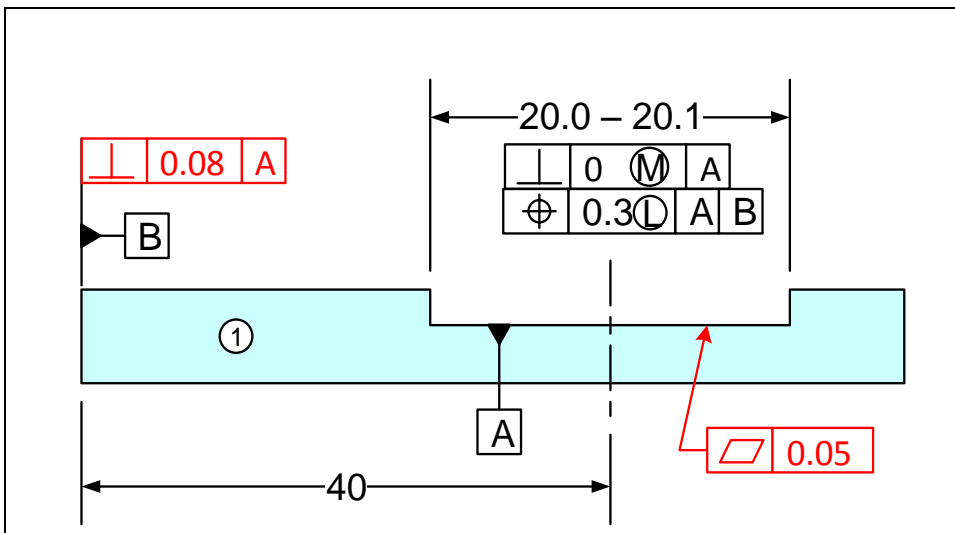


Figure 11-37. Tolerances of part<sub>1</sub> and the slot feature assuming the final arrangement of the slot fit is unpredictable during assembly

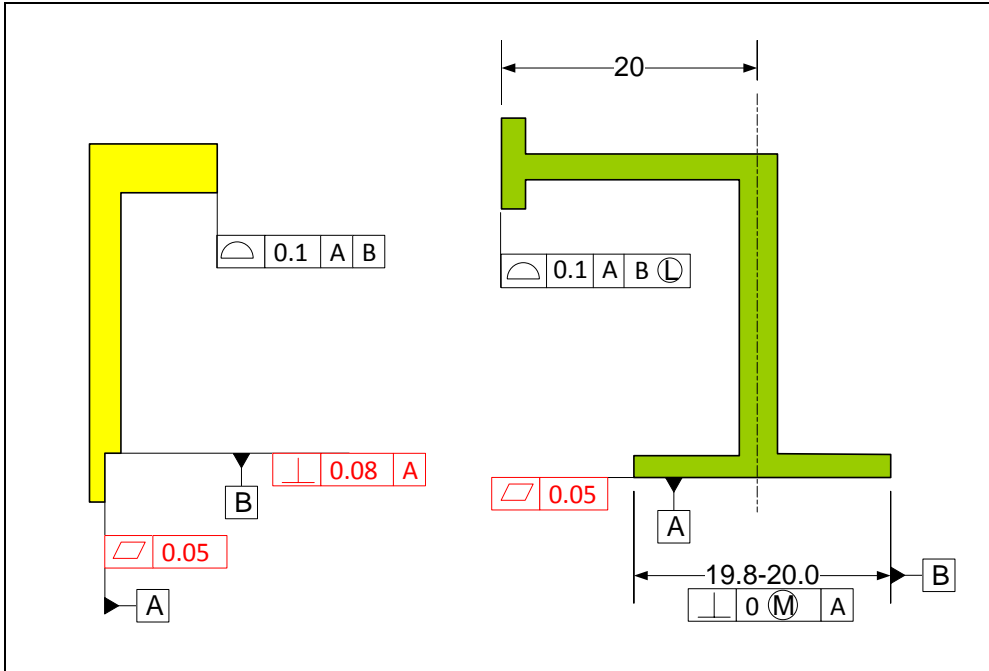


Figure 11-38. The initial assignment of tolerances

### Graphical Method

Figure 11-39 shows the tolerance loop for this example. When modeling, position deviations are treated separately and are not combined with cross-sectional sizes into fit-equivalent sizes.

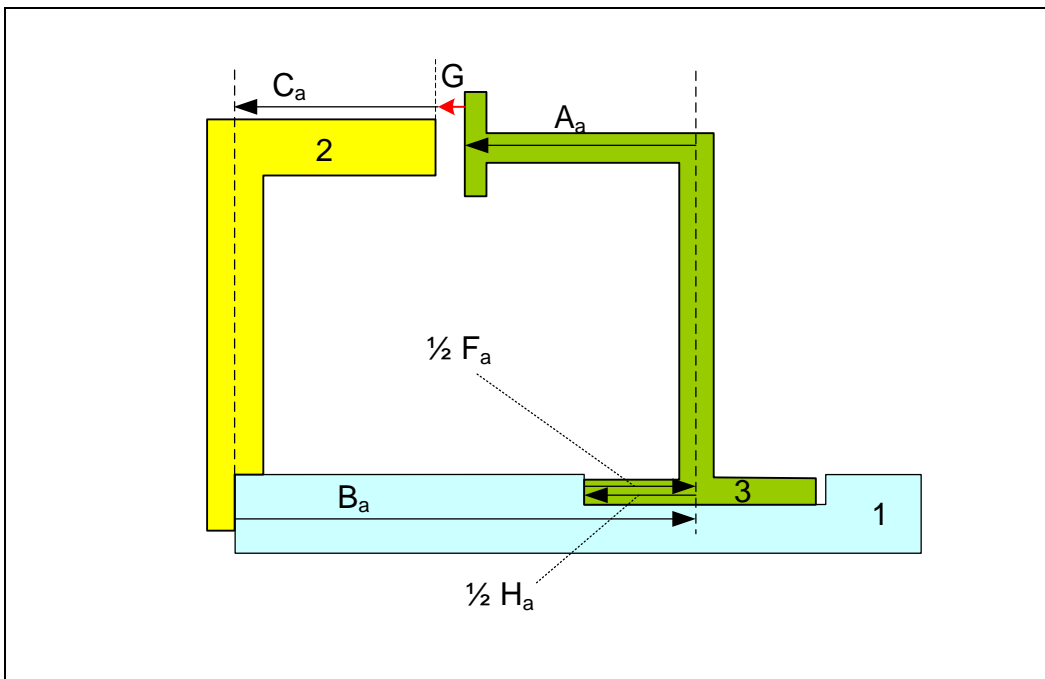


Figure 11-39. The tolerance loop for finding the minimum gap

When analyzing assemblies with loose parts we should place the loose parts in a fixed arrangement before proceeding with the analysis. An *arrangement* simply refers to a particular positioning of a loose part in a fit. For the worst-case analysis, we must use the worst arrangement for fit. In this problem, the rail must be pushed to the left to create the minimum gap. Recall that when the tolerances were designed in Chapter-10, the assumption was that this loose fit arrangement is unpredictable during assembly and might be positioned in the worst arrangement in regard to the main assembly fit.

The following table indicates the dimension limits to be used in the graphical modeling of the parts that lead to the minimum gap.

<b>Dimension</b>	<b>Part</b>	<b>Initial Value (Final Value)</b>	<b>State</b>
$(B_a)_{\min}$	Part <sub>1</sub>	39.85 (40.25)	-
$(C_a)_{\max}$	Part <sub>2</sub>	20.05	-
$(A_a)_{\max}$	Part <sub>3</sub>	20.05	-
$(H_a)_{\max}$	Part <sub>1</sub>	20.10	LMC
$(F_a)_{\min}$	Part <sub>3</sub>	19.80	LMC

Figure 11-40 shows the necessary features of the three parts along with the dimensions that lead to the minimum gap. The word “Align” in the figure indicates that the rail is pushed all the way to the left, touching the slot edge.

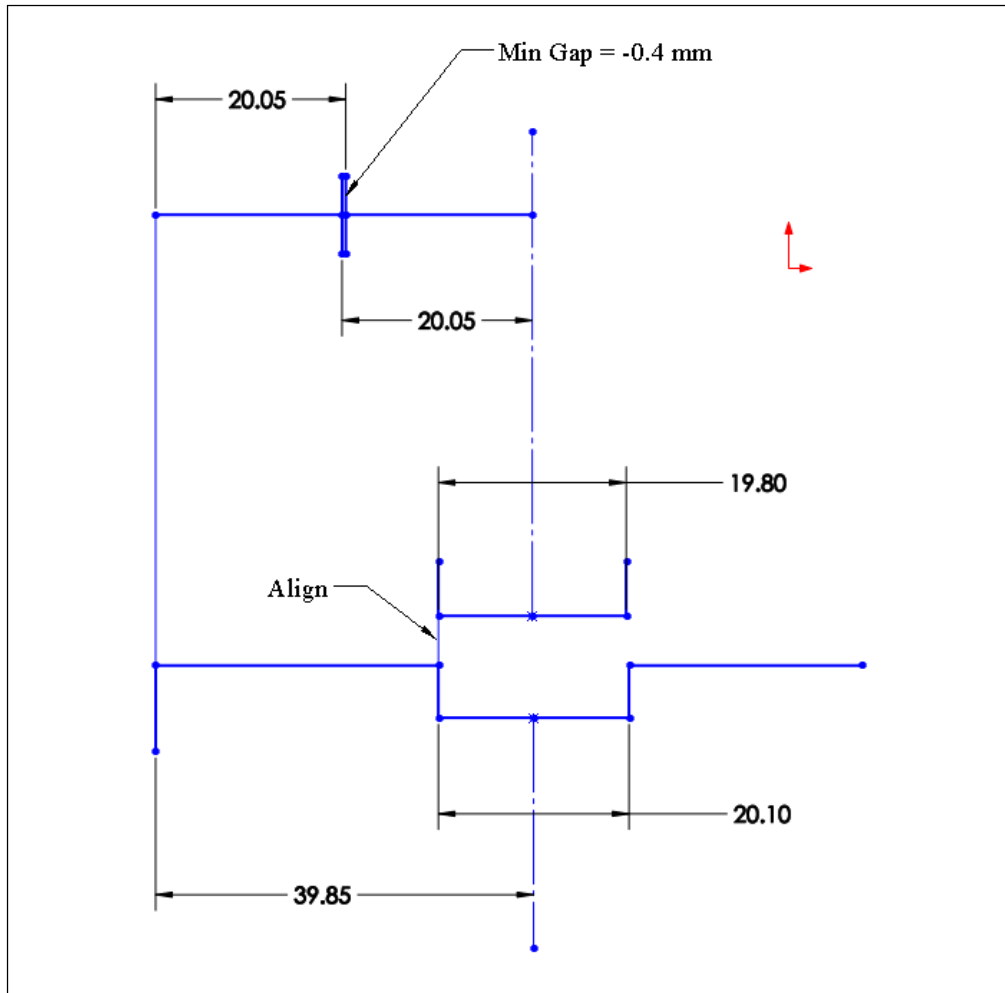


Figure 11-40. CAD sketch model of the assembly leading to a minimum gap

The minimum gap allowed by the initial dimension and tolerance values is an interference of 0.4 mm. We can adjust the 40 mm basic dimension in part<sub>1</sub> from 40 mm to 40.4 mm to set up the specification for a minimum gap of zero. The new minimum value of  $B_a$  becomes  $(40.4 - 0.15 = 40.25)$  mm and its maximum value becomes  $(40.4 + 0.15 = 40.55)$  mm).

For the maximum gap evaluation the arrangement changes with the loose fit pushed to the right making contact on the right edge of the slot. The table below shows the modeling values leading to the maximum gap.

Dimension	Part	Model Values	State
$(B_a)_{\max}$	Part <sub>1</sub>	40.55	-
$(C_a)_{\min}$	Part <sub>2</sub>	19.95	-
$(A_a)_{\min}$	Part <sub>3</sub>	19.95	-
$(H_a)_{\max}$	Part <sub>1</sub>	20.10	LMC
$(F_a)_{\min}$	Part <sub>3</sub>	19.80	LMC



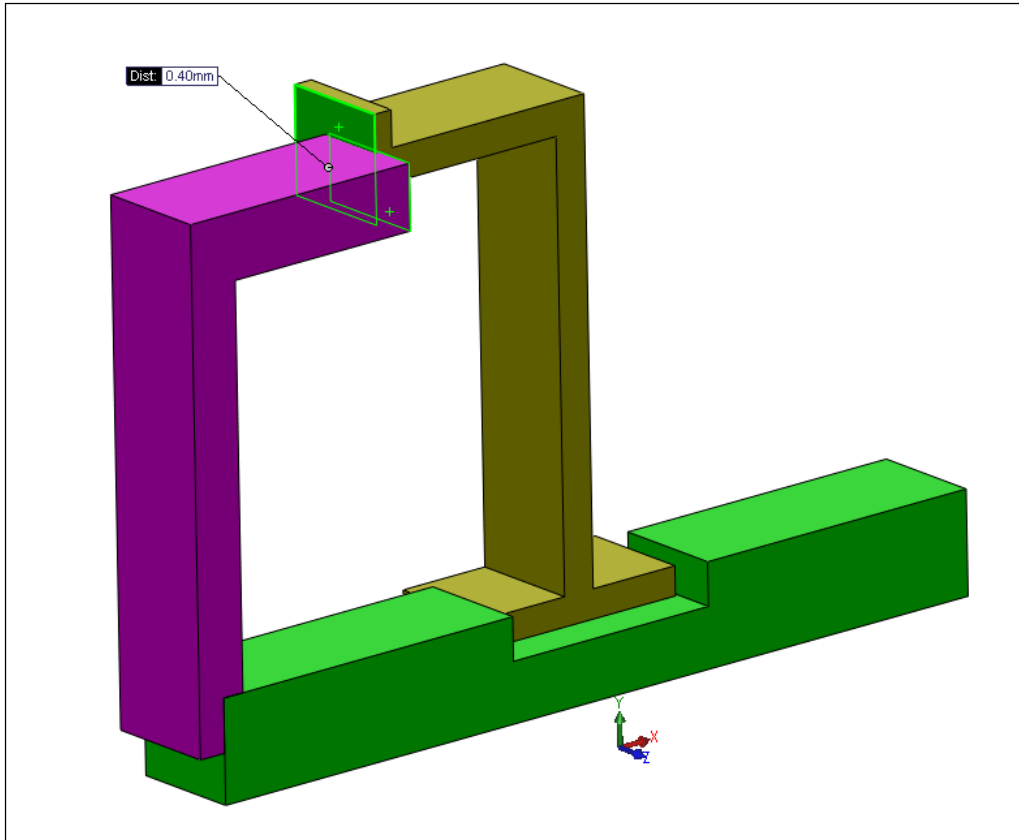


Figure 11-42. 3D model of the assembly

### Analytical Method

The tolerance loop equation is

$$G + C_a - B_a + \frac{1}{2} H_a - \frac{1}{2} F_a + A_a = 0 \rightarrow G = B_a - C_a - A_a - \frac{1}{2} H_a + \frac{1}{2} F_a$$

The minimum gap expression becomes

$$G_{\min} = (B_a - \frac{1}{2} H_a)_{\min} - (C_a)_{\max} - (A_a)_{\max} + \frac{1}{2} (F_a)_{\min}$$

The slot position and size deviations are not treated independently because the position deviation depends on the size of the feature. When the slot is at its LMC limit of size

$$(B_a - \frac{1}{2} H_a)_{\min} = \underline{B} - \frac{1}{2} T_H - \frac{1}{2} H_{\max}$$

The minimum gap becomes

$$G_{\min} = (\underline{B} - \frac{1}{2} T_H - \frac{1}{2} H_{\max}) - (\underline{C} + \frac{1}{2} T_C) - (\underline{A} + \frac{1}{2} T_A) + \frac{1}{2} F_{\min}$$

In this problem we will adjust the value of  $\underline{B}$  to achieve a zero minimum gap value.

Adding the profile tolerance and position tolerance leads to

$$G_{\min} = (\underline{B} - \frac{1}{2} T_H - \frac{1}{2} H_{\max}) - (\underline{C} + \frac{1}{2} T_C) - (\underline{A} + \frac{1}{2} T_A) + \frac{1}{2} F_{\min}$$

Substituting the numbers (except for the unknown  $\underline{B}$ ) leads to

$$G_{\min} = (\underline{B} - \frac{1}{2} (0.3) - \frac{1}{2} (20.1)) - (20 + \frac{1}{2} (0.1)) - (20 + \frac{1}{2} (0.1)) + \frac{1}{2} (19.8)$$

Setting  $G_{\min}=0$  and solving for  $\underline{B}$ , we get

$$\underline{B} = 40.4 \text{ mm}$$

Changing the 40 mm dimension in part<sub>1</sub> to 40.4 mm leads to a minimum gap of zero in the main assembly fit with the specified tolerances. The maximum gap occurs when the arrangement of the loose fit part changes and contact occurs on the right side as shown in Figure 11-43.

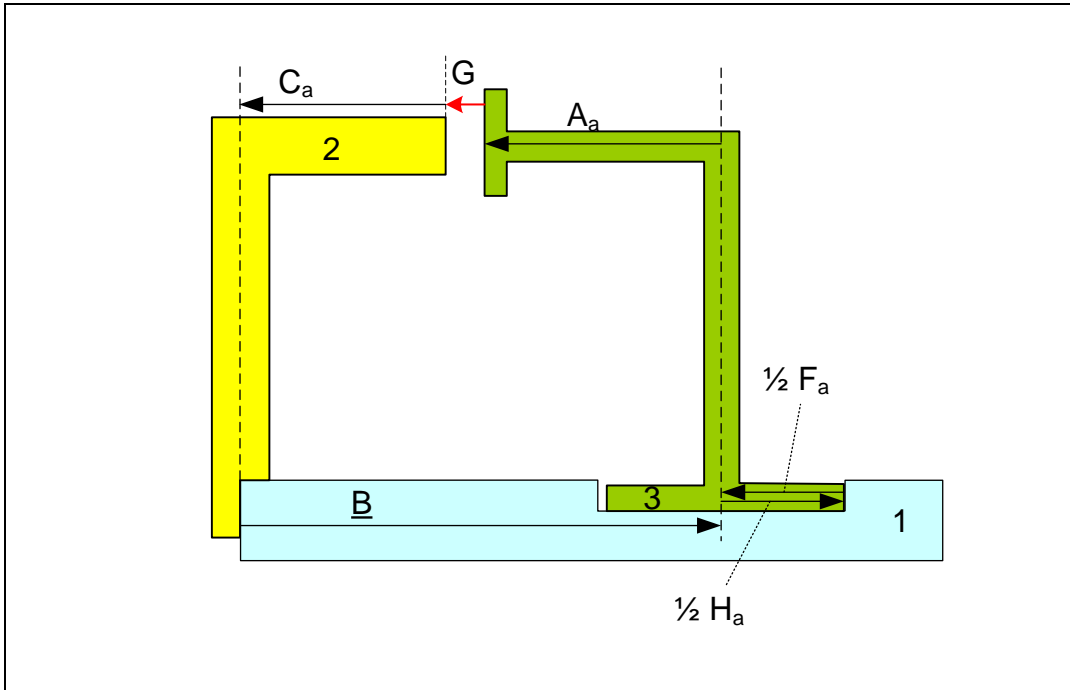


Figure 11-43. The tolerance loop for finding the maximum gap

As a result, the expression appropriate for maximum gap becomes

$$G = B_a - C_a - A_a + \frac{1}{2} H_a - \frac{1}{2} F_a$$

The maximum gap is

$$G_{\max} = (B_a + \frac{1}{2} H_a)_{\max} - (C_a)_{\min} - (A_a)_{\min} - (\frac{1}{2} F_a)_{\min}$$

Adding the tolerances, the maximum gap becomes

$$G_{\max} = (\underline{B} + \frac{1}{2} T_H + \frac{1}{2} H_{\max}) - (\underline{C} - \frac{1}{2} T_C) - (\underline{A} - \frac{1}{2} T_A) - \frac{1}{2} (F_{\min})$$

Substituting the values we get

$$G_{\max} = (40.4 + \frac{1}{2} (0.3) + \frac{1}{2} (20.1)) - (20 - \frac{1}{2} (0.1)) - (20 - \frac{1}{2} (0.1)) - \frac{1}{2} (19.8)$$

The maximum gap becomes

$$G_{\max} = 0.8 \text{ mm}$$

Figure 11-44 shows the TAP results for the final dimensions that lead to zero minimum gap. Note that the tolerance loop for calculating the minimum gap is different than that for the maximum gap. The TAP dialog box shows the data for the vectors involved in the loop for the minimum gap. When entering the position tolerance data, the theoretical position is entered as a basic dimension and the size feature is associated with a position tolerance. In the dialog box the 40.4 mm is the basic location of the slot feature. The size and position tolerance specifications of the slot are entered in the fourth line.

Vector Type	Coefficient	Minimum (L)	Maximum (W)	Tol Type	Tol Value	Qualifier
Basic	1	40.4	21	Position	0.1	M
Profile	-1	19.95	20.05	Position	0.1	M
Profile	-1	19.95	20.05	Position	0.1	M
Size - Internal	-0.5	20.0	20.1	Position	0.3	L
Size - External	0.5	19.8	20.0	Form/Orient	0	M
	1	20	21	Position	0.1	M
	1	20	21	Position	0.1	M
	1	20	21	Position	0.1	M
	1	20	21	Position	0.1	M

Minimum gap 0.000  
 Maximum gap

Statistical Analysis

Enter Percentile between 0 and 100: 99.9

Min gap: 0.086

Max gap:

Save or Load Model

Example6a

Figure 11-44. The tolerance analysis program dialog screen for minimum gap in Example-6

Figure 11-45 shows the TAP results for the maximum gap.

Vector Type	Coefficient	Minimum (L)	Maximum (W)	Tol Type	Tol Value	Qualifier
Basic	1	40.4	21	Position	0.1	M
Profile	-1	19.95	20.05	Position	0.1	M
Profile	-1	19.95	20.05	Position	0.1	M
Size - Internal	0.5	20	20.1	Position	0.3	L
Size - External	-0.5	19.8	20	Form/Orient	0	M
	1	20	21	Position	0.1	M
	1	20	21	Position	0.1	M
	1	20	21	Position	0.1	M
	1	20	21	Position	0.1	M

Minimum gap  
 Maximum gap 0.800

Statistical Analysis

Enter Percentile between 0 and 100: 99.9

Min gap:

Max gap: 0.720

Save or Load Model

Example6b

Figure 11-45. The tolerance analysis program dialog screen for maximum gap in Example-6

### Example-7: A multipart tolerance design with tapered slot features

The assembly for Example-7 in Chapter-10 and the initial tolerancing assignment is shown in Figure 11-46, 11-47 and 11-48. We would like to adjust one of the theoretical

dimensions to obtain a zero minimum gap with the given tolerances. The theoretical angle of the tapered slot is 60 degrees.

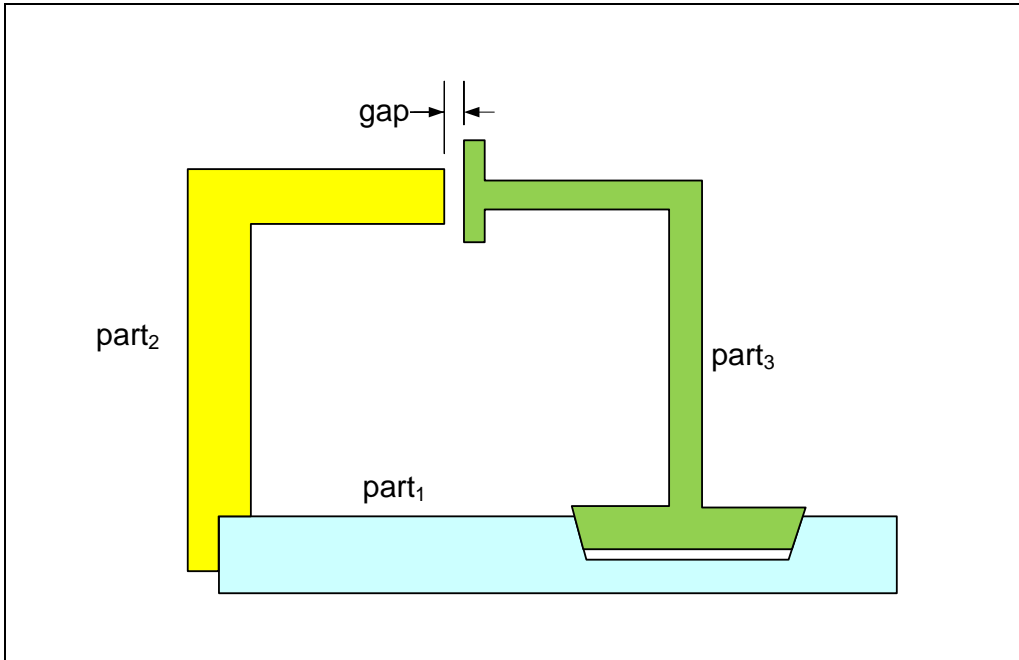


Figure 11-46. Tapered slots and rails eliminate play and fit misalignment

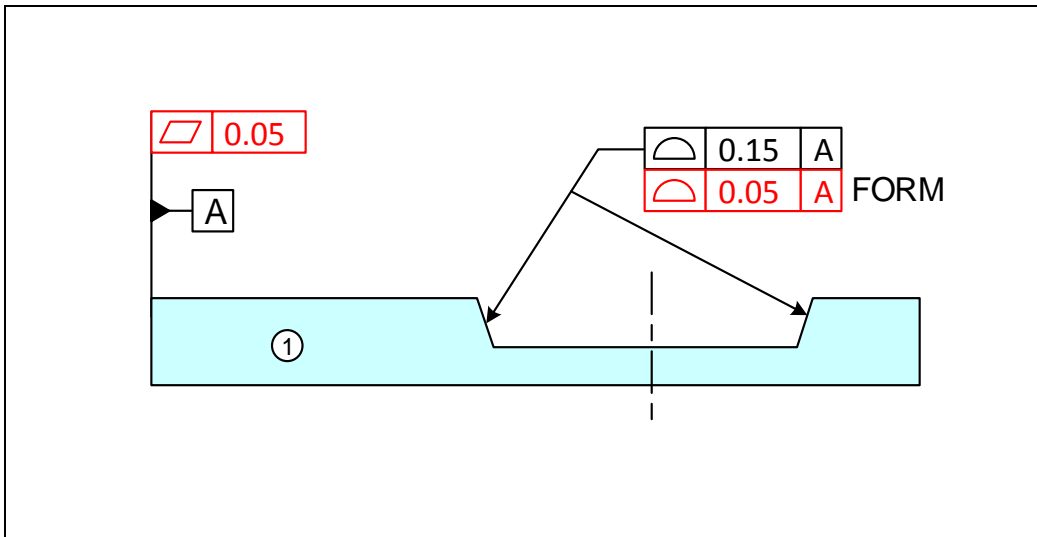


Figure 11-47. The initial assignment of tolerances for part<sub>1</sub>

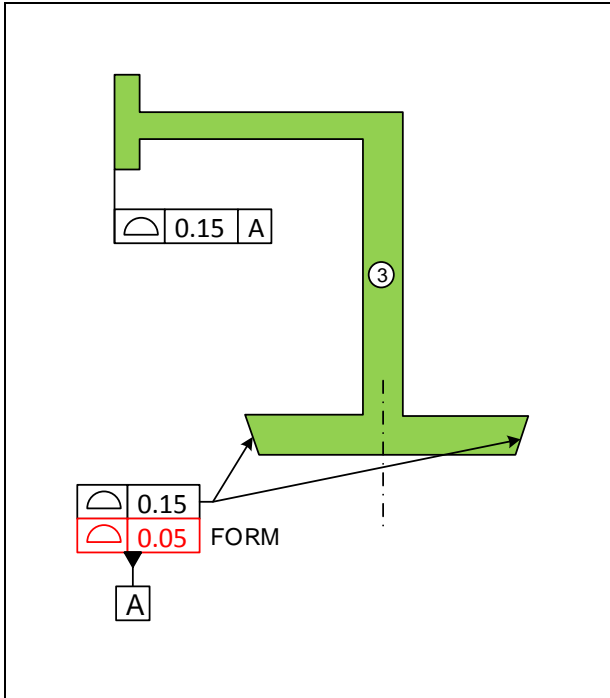


Figure 11-48. The initial assignment of tolerances for part 3

### Graphical Method

Figure 11-49 shows the tolerance loop for this example.

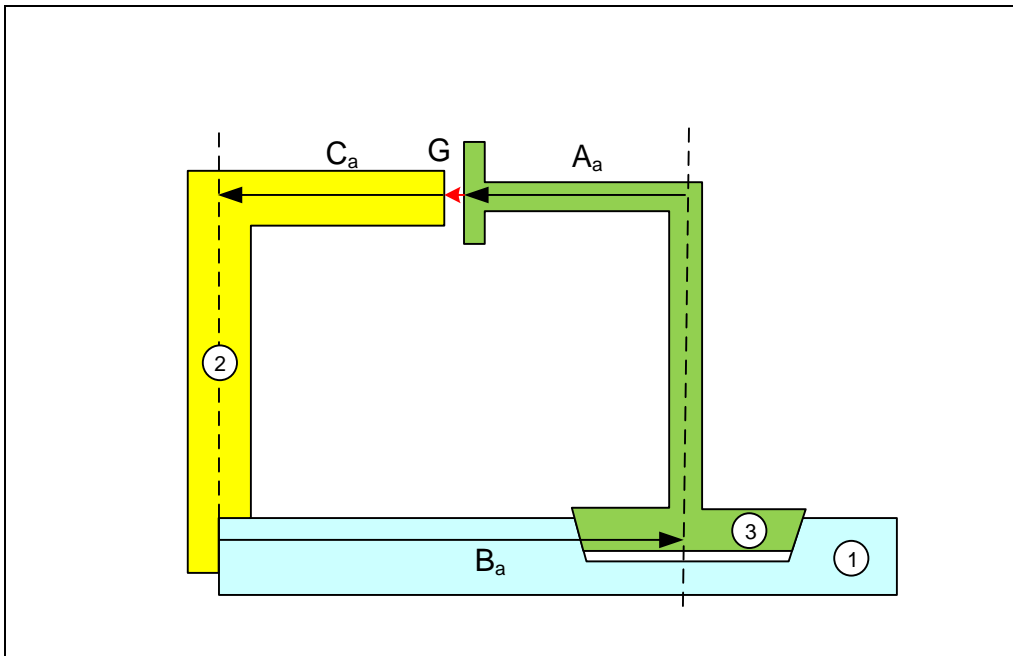


Figure 11-49. The tolerance loop

Vector  $A_a$  is associated with a profile tolerance. Vector  $B_a$  locates the tapered slot's center plane and is associated with a profile tolerance. Vector  $C_a$  is also associated with a profile tolerance. The following table indicates the dimension limits to be used in the graphical modeling of the parts that lead to the minimum gap.

Dimension	Part	Initial Value
$(B_a)_{min}$	Part <sub>1</sub>	39.9134 (see next page)
$(A_a)_{max}$	Part <sub>3</sub>	20.075
$(C_a)_{max}$	Part <sub>2</sub>	20.075

Figure 11-50 shows the sketch of the assembly and the three relevant dimensions for calculating the minimum gap. In comparison, the previous assembly with straight slot and rail features had five participating dimensions.

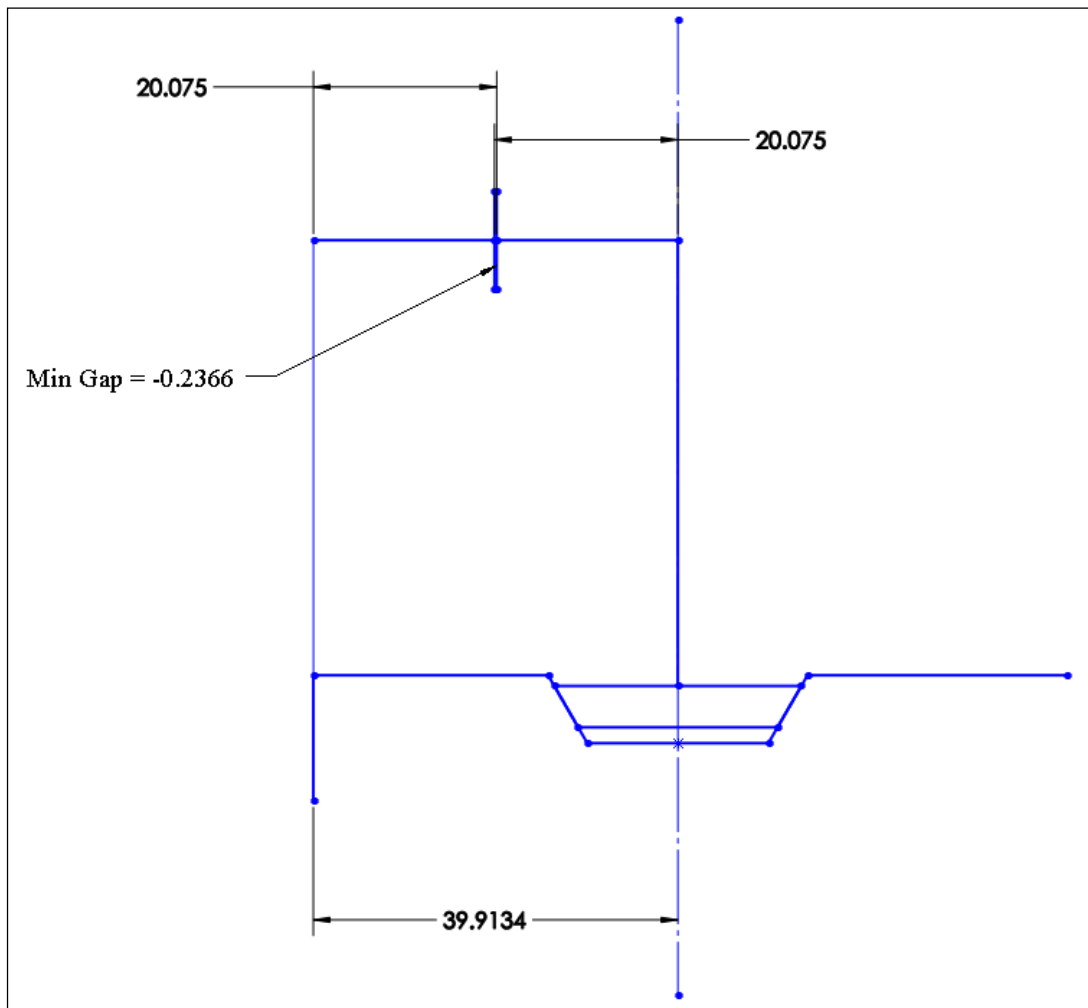
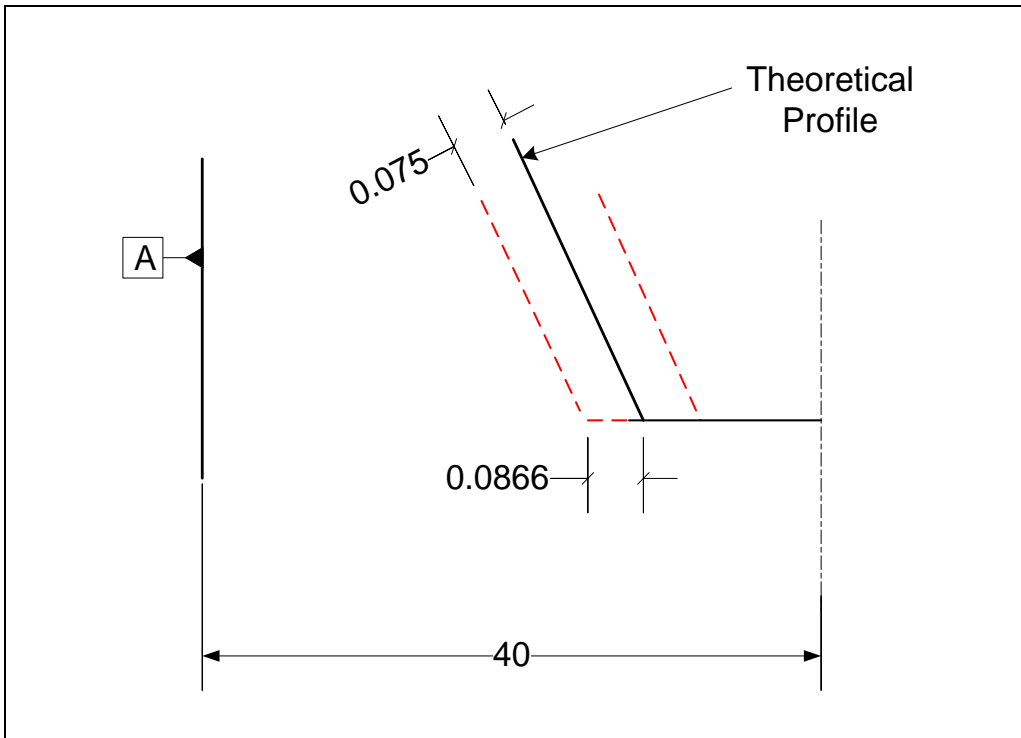


Figure 11-50. CAD sketch model of the assembly leading to a minimum gap

The 0.15 mm profile tolerance controls the size and location of the slot. Figure 11-51 shows the extreme position for the slot edge allowed by the tolerance.



**Figure 11-51. The influence of profile tolerance on a 60 degree taper in the direction of gap vector**

The depth of the profile tolerance zone is defined in the direction normal to the surface. Because of the 60 degree taper of the slot, the actual center plane of the slot can deviate from its 40 mm theoretical location by as much as

$$\delta = \frac{0.075}{\sin(60)} = 0.0866 \text{ mm}$$

This deviation can happen in either direction relative to the theoretical center plane. For the minimum gap calculation, the slot's actual center plane location is set to be closest to datum-A at a distance of

$$D = 40 - 0.0866 = 39.9134 \text{ mm}$$

This is the value used in the sketch assembly. We can also use the sketching tools of the modeler and calculate the resulting axis location of 39.9134 mm. Since the resulting fit gap becomes an interference of 0.2366 mm, we must adjust one of the dimensions. In this case, we will increase the 40 mm theoretical location value by 0.24 to 40.24 mm. The rounding up of this dimension leads to a small minimum gap value rather than zero.

For the maximum gap, the dimension values for part<sub>2</sub> and part<sub>3</sub> are 19.925 mm while the slot center plane must be dimensioned to its farthest distance of  $(40.24 + 0.0866) = 40.3266$  mm. The resulting maximum gap becomes 0.4766 mm. Note that the influence of the profile tolerance values applied to the straight slot surfaces is one-to-one while the influence of the profile tolerance value applied to the tapered slot is 1.15 to one. When the cost of reducing tolerances by a certain amount is the same, it is better to reduce the tolerances with the most influence on the gap.

Figure 11-52 shows the 3D solid model of the assembly as originally specified. The 0.2366 mm distance is the interference between the two shown surfaces.

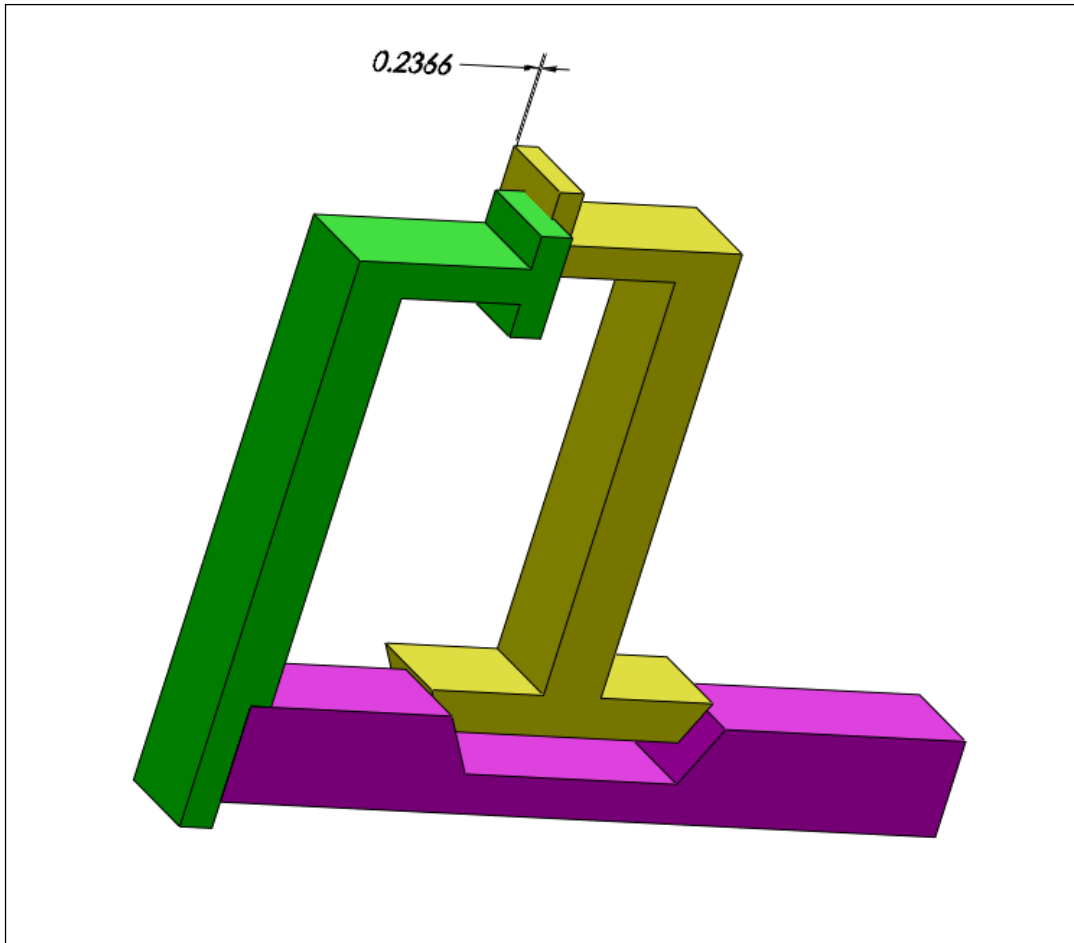


Figure 11-52. 3D model of the assembly

### Analytical Method

The loop equation for the minimum gap is

$$G + C_a - B_a + A_a = 0 \rightarrow G = B_a - A_a - C_a$$

The minimum gap expression is

$$G_{\min} = (B_a)_{\min} - (A_a)_{\max} - (C_a)_{\max}$$

Substituting for minimum and maximum values for profile tolerances

$$G_{\min} = (\underline{B} - \frac{1}{2} T_B \lambda) - (\underline{A} + \frac{1}{2} T_A) - (\underline{C} + \frac{1}{2} T_C)$$

$\lambda$  is the conversion factor for the effect of profile taper and is calculated as

$$\lambda = \frac{1}{\sin(60)} = 1.1547$$

Substituting for all values except  $\underline{B}$  results in

$$G_{\min} = (\underline{B} - \frac{1}{2} (0.15)(1.1547)) - (20 + \frac{1}{2} (0.15)) - (20 + \frac{1}{2} (0.15))$$

Setting  $G_{\min}=0$  and solving for  $\underline{B}$  yields

$$\underline{B} = 40.2366 \text{ mm}$$

Rounding  $\underline{B}$  up to 40.24 mm leads to a slight minimum gap of 0.0034 mm. The maximum gap expression is

$$G_{\max} = (\underline{B} + \frac{1}{2} T_B \lambda) - (\underline{A} - \frac{1}{2} T_A) - (\underline{C} - \frac{1}{2} T_C)$$

Substituting the numbers

$$G_{\max} = (40.24 + \frac{1}{2} (0.15)(1.1547)) - (20 - \frac{1}{2} (0.15)) - (20 - \frac{1}{2} (0.15))$$

The maximum gap becomes

$$G_{\max} = 0.4766 \text{ mm}$$

Figure 11-53 shows the TAP results for the final dimensions that lead to the minimum gap of zero. For the slot, the final dimensions are a basic dimension of 40.2366 mm and a profile tolerance of 0.15 mm. Because the profile tolerance has an influence of 1.15-to-one on the gap it is best to break vector B into a basic dimension vector and a profile vector as shown in the TAP model. In this format changes to the slot profile tolerance will correctly reflect on the gap dimension.

Vector Type	Coefficient	Minimum (L)	Maximum (W)	Tol Type	Tol Value	Qualifier
Basic	1	40.2366	40.3232	Position	0.1	M
Profile	-1.15	-0.075	0.075	Position	0.1	M
Profile	-1	19.925	20.075	Position	0.1	M
Profile	-1	19.925	20.075	Position	0.1	M
	1	20	21	Position	0.1	M
	1	20	21	Position	0.1	M
	1	20	21	Position	0.1	M
	1	20	21	Position	0.1	M

Minimum gap 0.000

Maximum gap 0.473

Statistical Analysis

Enter Percentile between 0 and 100: 99.9

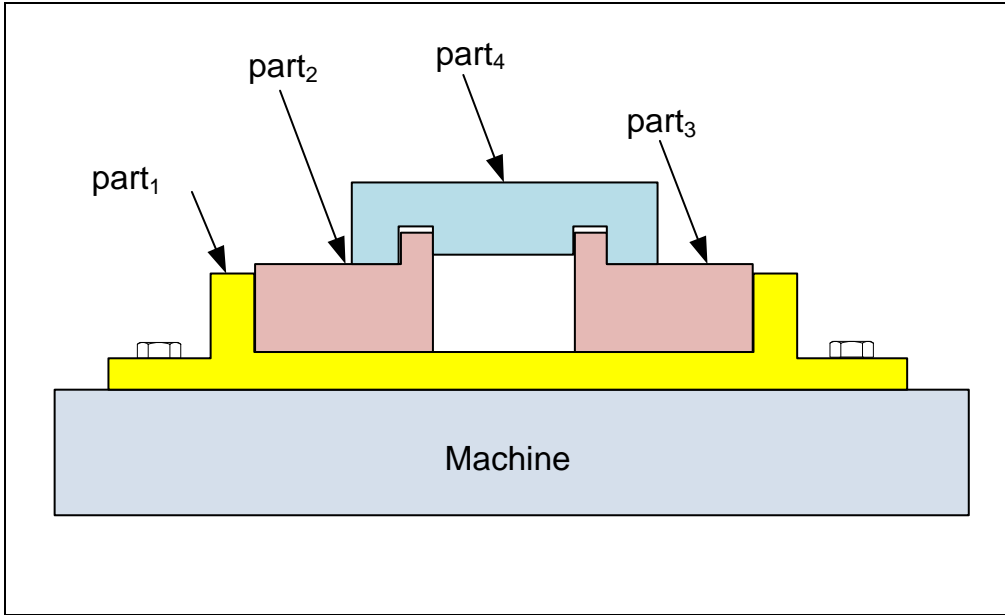
Min gap: 0.032

Max gap: 0.441

Figure 11-53. The tolerance analysis program dialog screen for the gap in Example-7

### Example-8: An assembly with multi fit features

Figure 11-54 shows an attachment of four parts to a machine frame. This assembly was presented as an exercise problem in Chapter-10. We like to specify the tolerances for a minimum gap of zero. The order of assembly is identified by part numbers and we know that part<sub>4</sub> is going to be assembled last. Assume that part<sub>2</sub> and part<sub>3</sub> have identical specifications and they are glued to part<sub>1</sub>.



**Figure 11-54. A multipart assembly with fit features assembled last**

Figure 11-55 shows the result of initial tolerance allocations as presented in Chapter-10.

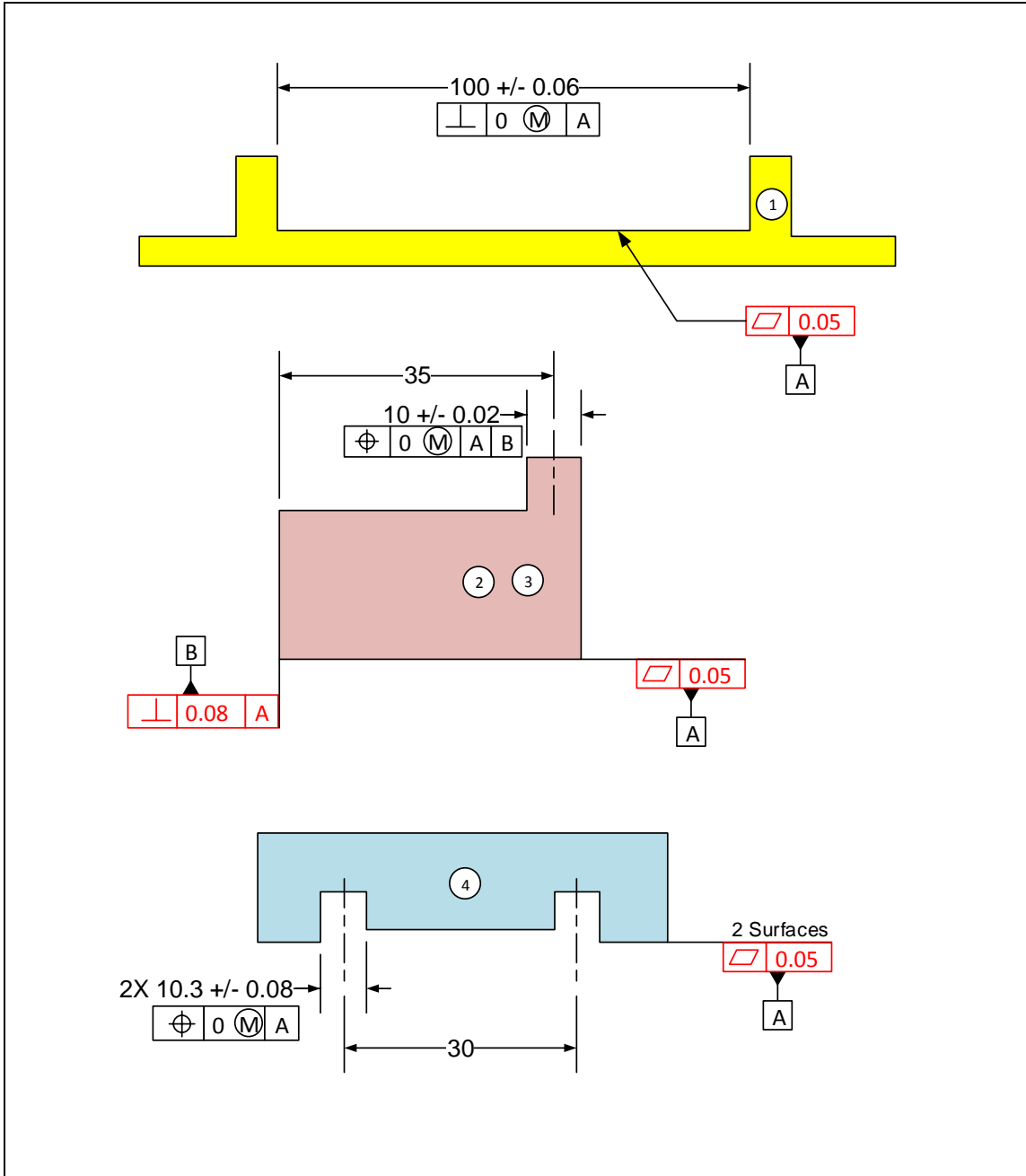
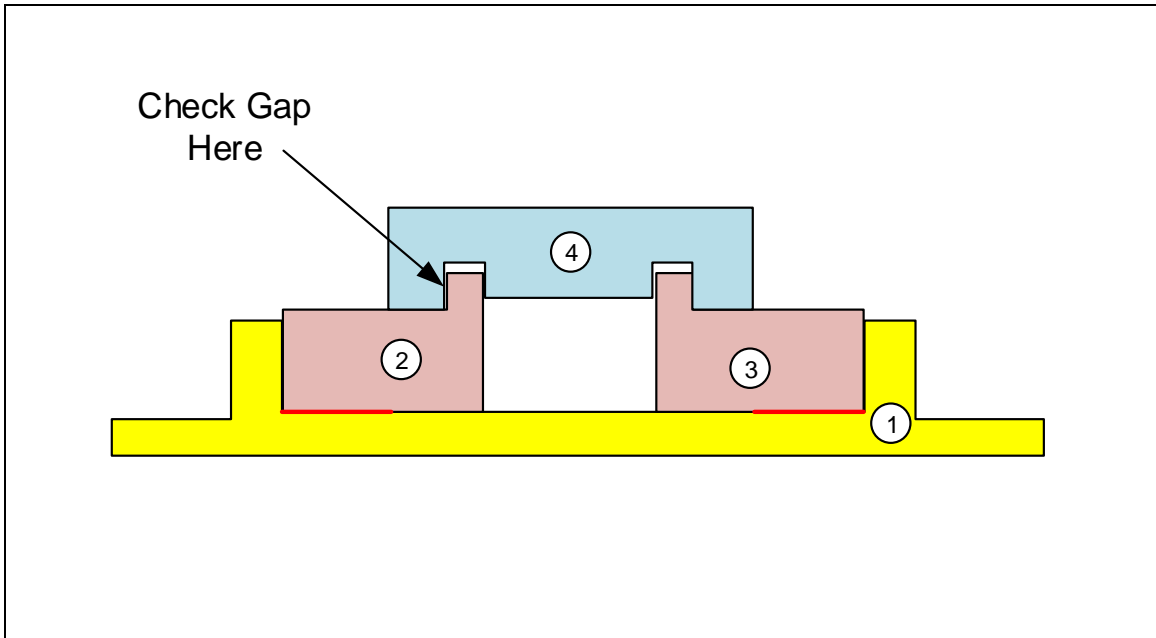


Figure 11-55. The initial assignment of theoretical dimensions and tolerances

### Graphical Method

Figure 11-56 shows how this problem can be set up for a CAD sketch model solution. After the first three parts are fixed in place we lower part<sub>4</sub> and make contact with the right edge of the right rail. After this contact, part<sub>4</sub> can no longer slide to the left. If interference occurs on the left edge of the left rail, part<sub>4</sub> will not fit.



**Figure 11-56. An arrangement of parts suitable to check the minimum gap**

By inspection, the worst condition for assembly occurs when the slot in part<sub>1</sub> has its largest size at LMC and the other fit features are at their MMC limits of size. Since position tolerances are zero at MMC, the actual center distances remain as the theoretical values for the rails and slots. Figure 11-57 shows the sketch of the assembly and the relevant dimensions for calculating the minimum gap.

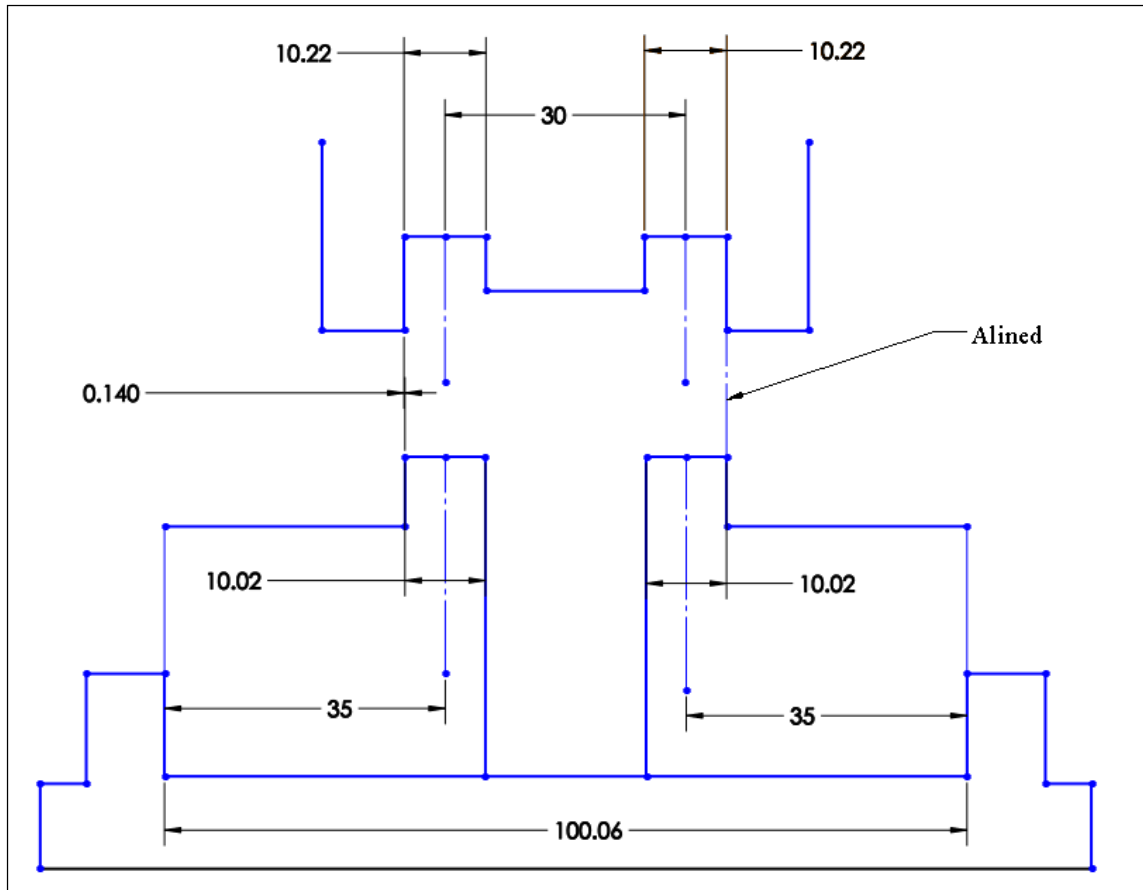


Figure 11-57. CAD sketch model of the assembly leading to a minimum gap

The results show a minimum gap of 0.14 mm. To set this gap to zero we can decrease the theoretical distance of 30 mm between the slots in part<sub>4</sub> to 29.86 mm. The maximum gap in the fit of part<sub>4</sub> is determined by individual slot and rail fits. In this case, the maximum play can be as much as

$$G_{\max} = H_{\max} - F_{\min} = 10.38 - 9.98 = 0.4 \text{ mm}$$

Figure 11-58 shows the 3D solid model of the assembly using the given design dimensions. The 0.14 mm is the distance between the surfaces that define the gap.

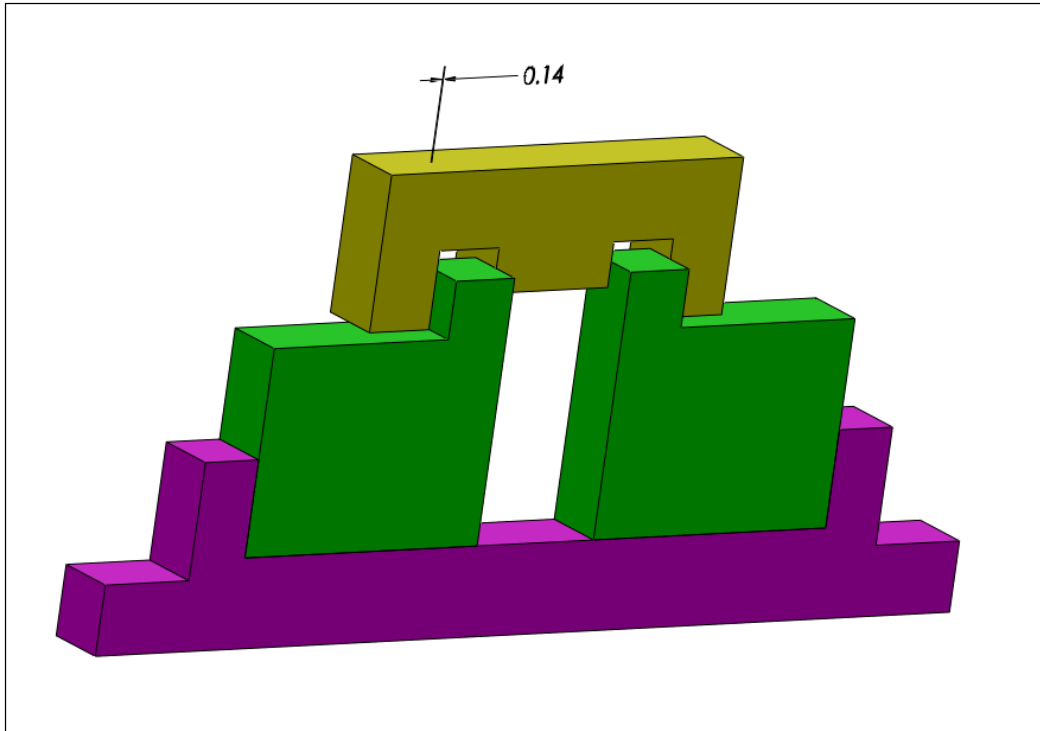
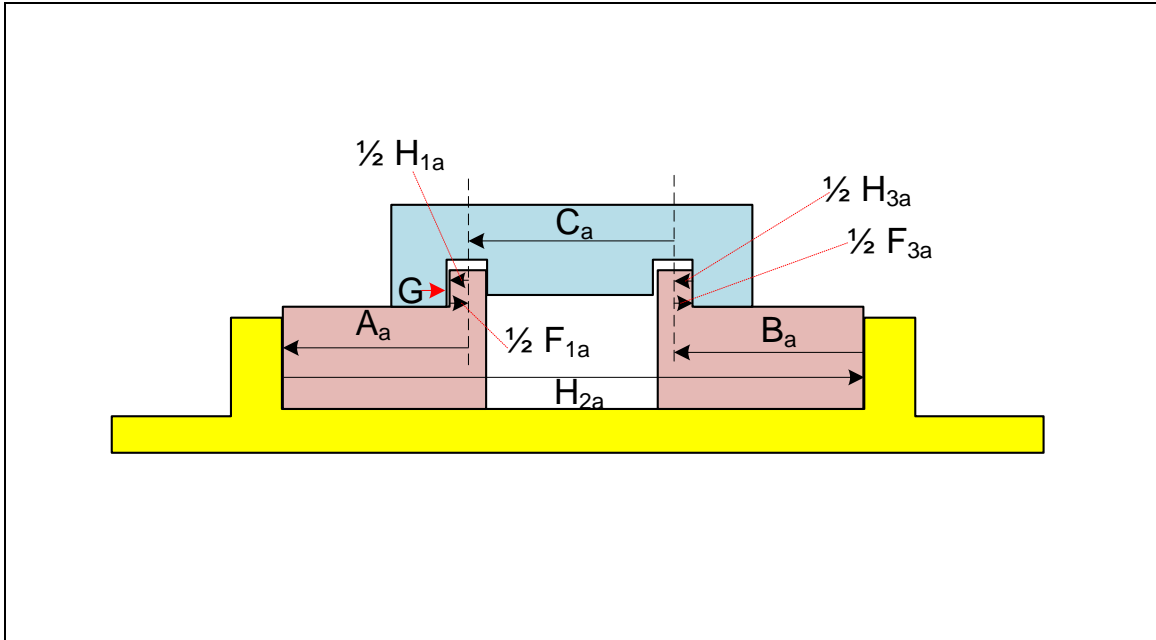


Figure 11-58. 3D model of the assembly

### Analytical Method

Figure 11-59 shows the tolerance loop for this assembly. The assembly parameter is the gap in the slot and rail fit between part<sub>2</sub> and part<sub>4</sub>. Part<sub>4</sub> is pushed to the left to touch part<sub>3</sub> and to create maximum space for the gap. If in this arrangement the gap can become negative, there would be a chance for part<sub>4</sub> not to fit.



**Figure 11-59. The tolerance loop**

The tolerance loop components are explained in the following list starting with the gap vector:

- G: Connects the surface of the slot to the surface of the rail.
- $\frac{1}{2} F_{1a}$ : Connects the surface of the rail to the actual center plane of the rail.
- $A_a$ : Connects the actual center plane of the rail to the datum plane.
- $H_{2a}$ : Connects the left side of the slot to the right side of the slot.
- $B_a$ : Connects the right side of the slot to the actual center plane of the rail.
- $\frac{1}{2} F_{3a}$ : Connects the actual center plane of the rail to the surface of the rail.
- $\frac{1}{2} H_{3a}$ : Connects the surface of the slot to the actual center plane of the slot.
- $C_a$ : Connects the actual center plane of the right slot to the actual center plane of the left slot.
- $\frac{1}{2} H_{1a}$ : Connects the actual center plane of the left slot to the surface of the left slot closing the loop.

The loop equation is

$$G + \frac{1}{2} F_{1a} - A_a + H_{2a} - B_a + \frac{1}{2} F_{3a} - \frac{1}{2} H_{3a} - C_a - \frac{1}{2} H_{1a} = 0$$

Setting up the terms for the minimum gap for all zero position tolerances leads to

$$G_{\min} = (\underline{A} + \underline{B} + \underline{C}) + (\frac{1}{2} H_{1a} + \frac{1}{2} H_{3a})_{\min} - (\frac{1}{2} F_{1a} + \frac{1}{2} F_{3a})_{\max} - (H_{2a})_{\max}$$

Choosing to adjust  $\underline{C}$ , the minimum gap becomes

$$G_{\min} = (35 + 35 + \underline{C}) + \frac{1}{2} (10.22) + \frac{1}{2} (10.22) - \frac{1}{2} (10.02) - \frac{1}{2} (10.02) - 100.06$$

Setting the minimum gap to zero and solving for  $\underline{C}$  results in

$$\underline{C} = 29.86 \text{ mm}$$

The result agrees with the graphical solution. The maximum gap is

$$G_{\max} = H_{\max} - F_{\min} = 10.38 - 9.98 = 0.4 \text{ mm}$$

Figure 11-60 shows the TAP results for the final dimensions that lead to the minimum gap of zero. The gap expression is

$$G = -\frac{1}{2} F_{1a} + \underline{A} - H_{2a} + \underline{B} - \frac{1}{2} F_{3a} + \frac{1}{2} H_{3a} + \underline{C} + \frac{1}{2} H_{1a}$$

Vector Type	Coefficient	Minimum (L)	Maximum (W)	Tol Type	Tol Value	Qualifier
Size - External	-0.5	9.98	10.02	Position	0	M
Basic	1	35	21	Position	0.1	M
Size - Internal	-1	99.94	100.06	Form/Orient	0	M
Basic	1	35	10.02	Position	0	M
Size - External	-0.5	9.98	10.02	Position	0	M
Size - Internal	0.5	10.22	10.38	Position	0	M
Basic	1	29.86	21	Position	0.1	M
Size - Internal	0.5	10.22	10.38	Position	0	M
	1	20	21	Position	0.1	M
	1	20	21	Position	0.1	M

Minimum gap 0.000  
 Maximum gap

Statistical Analysis

Enter Percentile between 0 and 100: 99.9

Min gap: 0.040

Max gap:

Figure 11-60. The tolerance analysis program dialog screen for the gap in Example-8

We can combine the three basic dimension vectors into one to reduce the number of input vectors. The dimension value of the combined vector would be

$$\underline{M} = 35+35+29.86 = 99.86 \text{ mm}$$

### Example-9: Fit formula for a floating fastener assembly

The floating fastener assembly was introduced in Chapter-9 along with the floating fastener formula that assured fit of this common three-piece assembly as shown in Figure 11-61. The derivation of the floating fastener formula, however, was not presented in Chapter-9. This formula is now derived using the tolerance loop method as another example of tolerance analysis procedure.

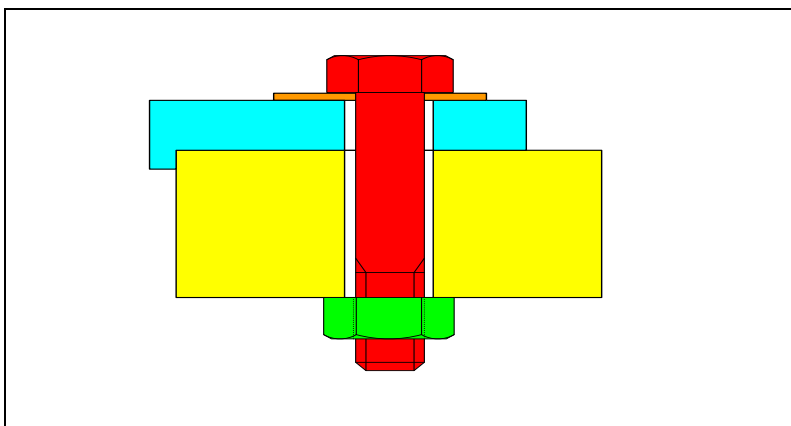


Figure 11-61. The floating fastener assembly

To set up this problem, we select to analyze the gap between the top plate and the bolt. As shown in Figure 11-62, the bolt, which is placed last and is the only loose part, is pushed to the right to make contact with the lower plate. If in this configuration the gap  $G$  becomes negative, the bolt will not fit through.

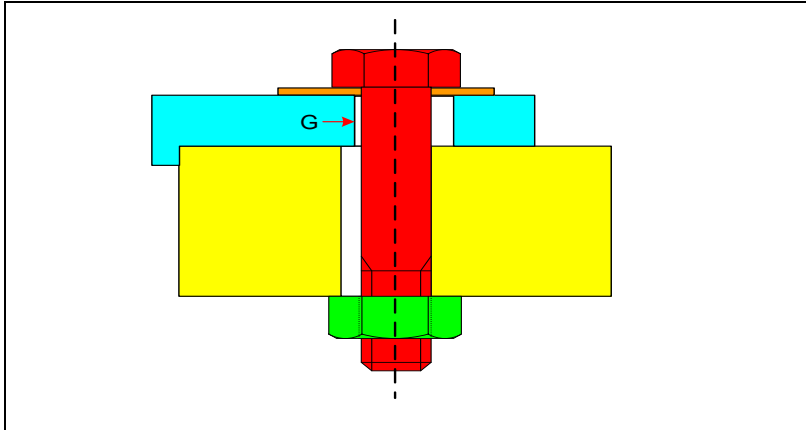


Figure 11-62. The necessary arrangement for studying the gap vector

### Graphical Method

Figure 11-63 shows the sketch assembly for a 14 mm bolt when the MMC sizes of the holes are 15 mm and the position tolerances at MMC are 0.5 mm. The basic hole location is 50 mm in this case. The resulting minimum gap is shown to be 0.5 mm.

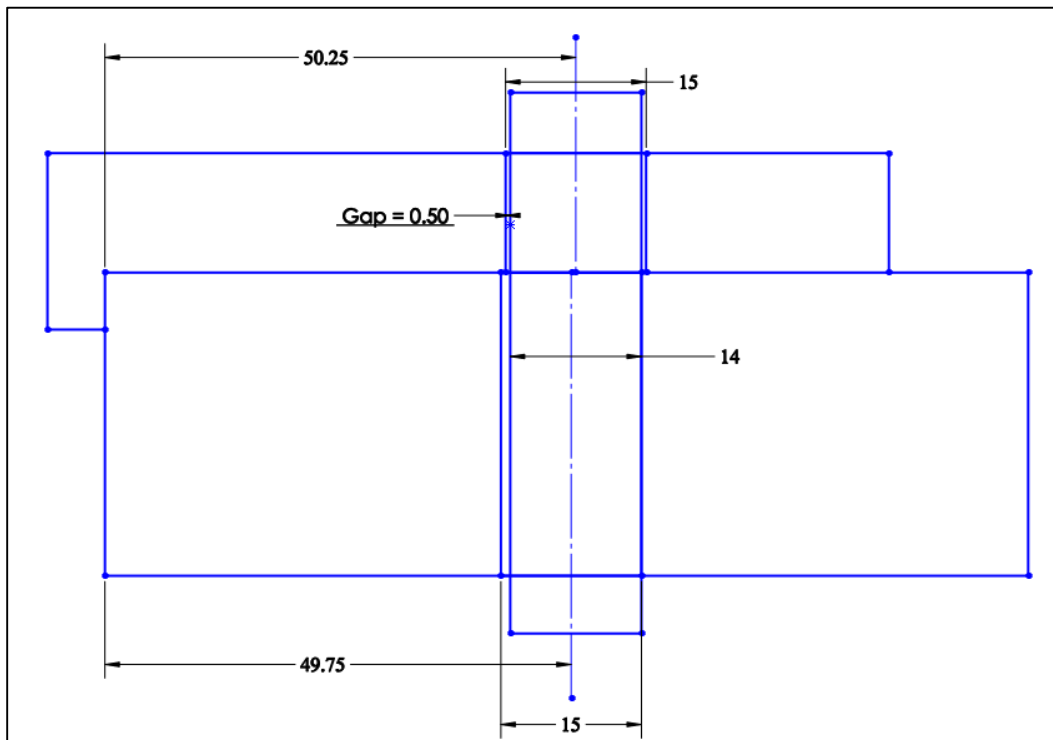


Figure 11-63. The sketch assembly for a floating fastener application

To reduce the minimum gap to zero, we can reduce the hole sizes, or we can relax the position tolerances from 0.5 mm to 1 mm. In this case we will relax the position tolerances. The result is shown in Figure 11-64.

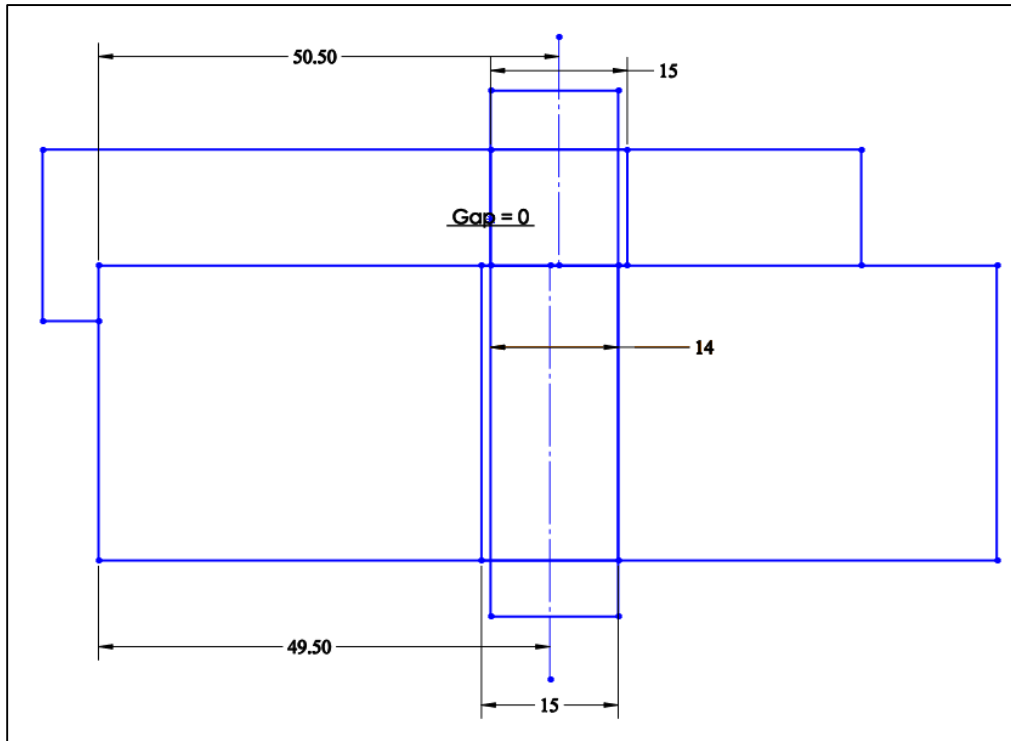


Figure 11-64. New dimensions in floating fastener assembly leading to a gap of zero

Figure 11-65 shows the cutaway 3D model assembly of the floating fastener situation and the resulting minimum gap of 0.5 mm for the initial design dimensions and tolerances. To create the minimum gap arrangement the two plates are first constrained together. The bolt is then inserted and constrained to have its shank tangent to the hole in the lower plate. The resulting gap between the top plate hole and the bolt becomes 0.5 mm.

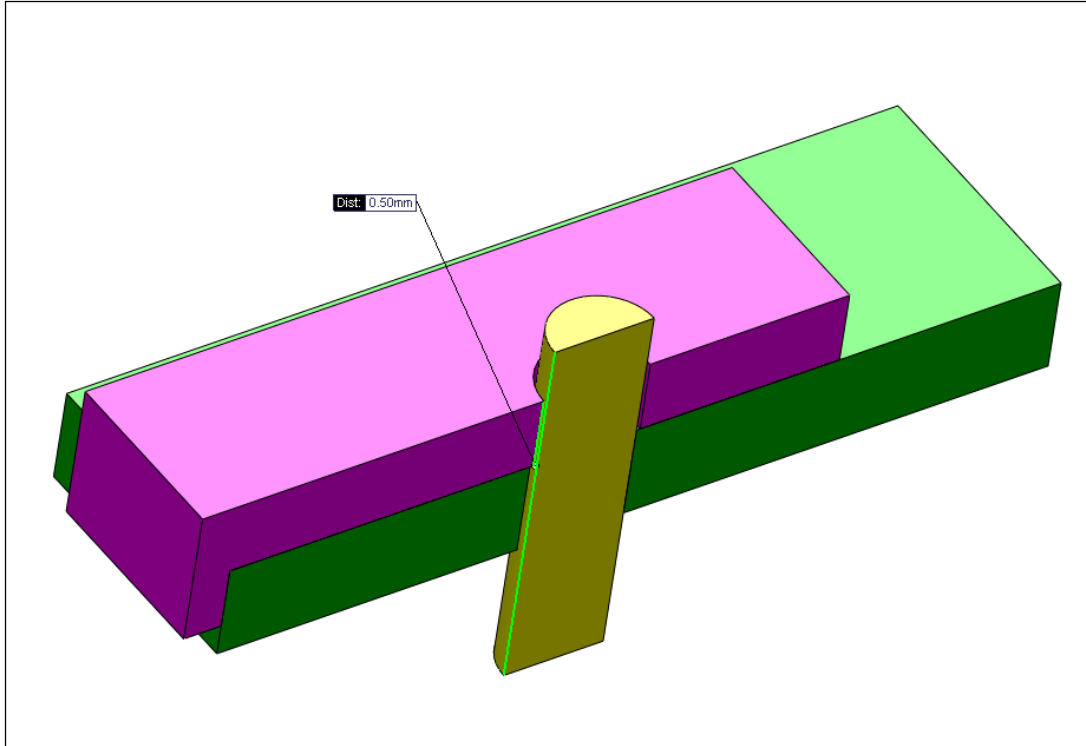


Figure 11-65. 3D cutaway model of the floating fastener situation

### Analytical Method

The loop vectors can be set up as shown in Figure 11-66. The dashed line indicates the theoretical location of the two holes. The theoretical locations of the two holes must be the same in order to obtain the best tolerance values.

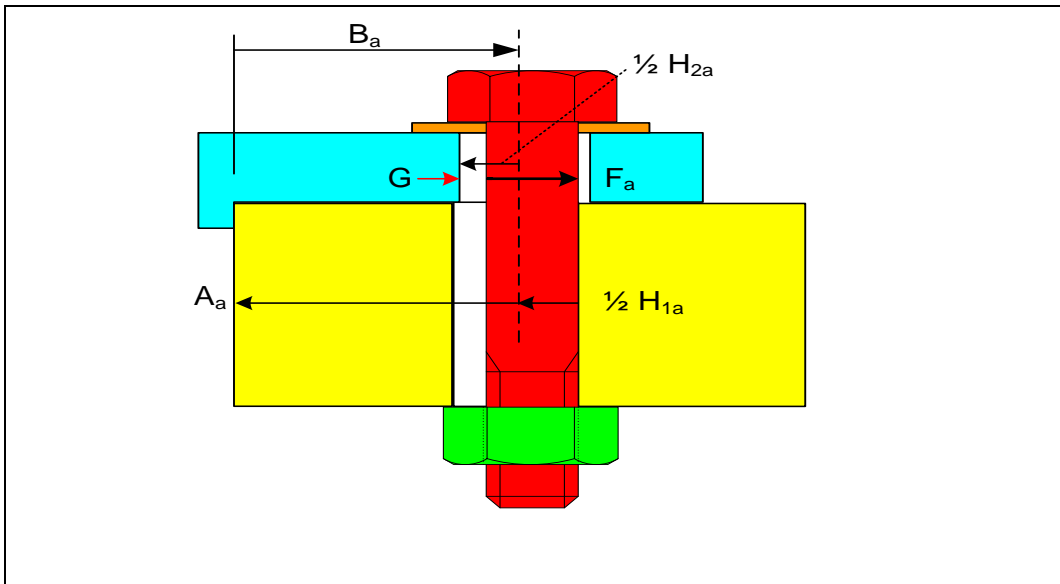


Figure 11-66. The tolerance loop for predicting the gap minimum size

The gap expression is

$$G = \frac{1}{2} H_{2a} - F_a + \frac{1}{2} H_{1a} + A_a - B_a$$

Since the theoretical positions are equal, the expression for  $G_{\min}$  becomes

$$G_{\min} = \frac{1}{2} (H_{2\min}) - F_{\max} + \frac{1}{2} (H_{1\min}) - \frac{1}{2} T_{H1} - \frac{1}{2} T_{H2}$$

$T_{H1}$  and  $T_{H2}$  are hole position tolerances. Bolt shank has a zero perpendicularity tolerance at MMC. Rearranging the terms

$$G_{\min} = \frac{1}{2} (H_{1\min} + H_{2\min}) - F_{\max} - \frac{1}{2} (T_{H1} + T_{H2})$$

The zero minimum gap fit formula becomes

$$T_{H1} + T_{H2} \leq (H_{1\min} + H_{2\min}) - 2F_{\max}$$

This is the formula presented in Chapter-9 as the floating fastener formula.

If we substitute the numbers used in the graphical analysis we get

$$T_{H1} + T_{H2} \leq (15 + 15) - 2(14) = 2 \text{ mm}$$

When position tolerances are divided equally, a position tolerance of 1 mm is required for each hole as in the graphical solution.

Figure 11-67 shows the result of TAP analysis and simulation for a 14 mm bolt fitting 15 mm MMC size holes. The analysis is for the final result of 50 mm basic position for holes with 1 mm position tolerance values for each hole.

Since A and B are both 50 mm, we do not need to add these vectors in the TAP dialog window. We do not need the maximum sizes of the holes or the minimum size of the bolt to analyze the minimum gap value but for the program input we will use 0.5 mm size tolerances for holes and 0.1 mm size tolerance for the bolt. The exact value of the size tolerance for standard bolts can be looked up in machine design books.

Vector Type	Coefficient	Minimum (L)	Maximum (W)	Tol Type	Tol Value	Qualifier
Size - Internal	0.5	15.0	15.5	Position	1	M
Size - External	-1	13.9	14.0	Form/Orient	0	M
Size - Internal	0.5	15.0	15.5	Position	1	M
	1	20	21	Position	0.1	M
	1	20	21	Position	0.1	M
	1	20	21	Position	0.1	M
	1	20	21	Position	0.1	M

Minimum gap 0.000

Maximum gap

**Statistical Analysis**

Enter Percentile between 0 and 100 99.9

Min gap 0.078

Max gap

Figure 11-67. The result of TAP worst-case analysis and statistical simulation for floating fasteners

The maximum gap is dictated by the difference between the hole and bolts LMC sizes. In this case the worst-case maximum gap is:

$$G_{\max} = 15.5 - 13.9 = 1.6 \text{ mm}$$

When the gap is influenced by vectors that do not all line up in the same direction the problem becomes a two-dimensional tolerance analysis. Analytical procedures can become cumbersome with two-dimensional problems. Two-dimensional problems are best analyzed graphically, or, with simulation software capable of handling two-dimensional problems.

### Example-10: Multipart tolerance analysis involving cylindrical fit features

Figure 11-68 shows a simple three-part assembly in which the fit is influenced by dimensional variations in two directions.

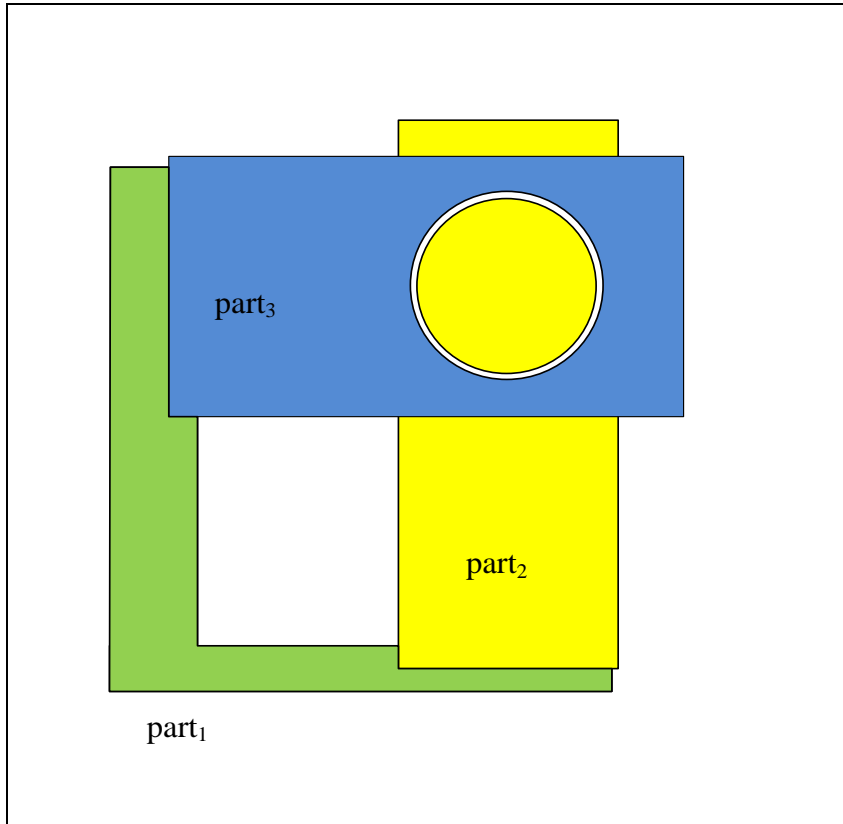


Figure 11-68. A three-part assembly with cylindrical fit features

Figure 11-69 and Figure 11-70 show the tolerancing design solution presented previously in Chapter-10. This two-dimensional tolerance analysis problem will only be solved graphically.

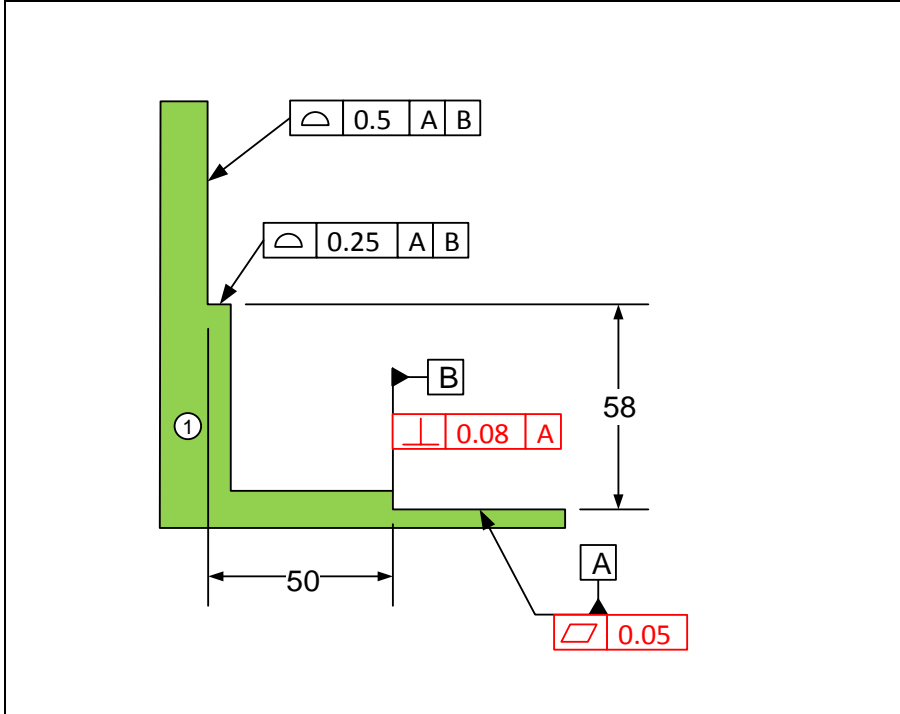


Figure 11-69. Initial tolerances for part<sub>1</sub>

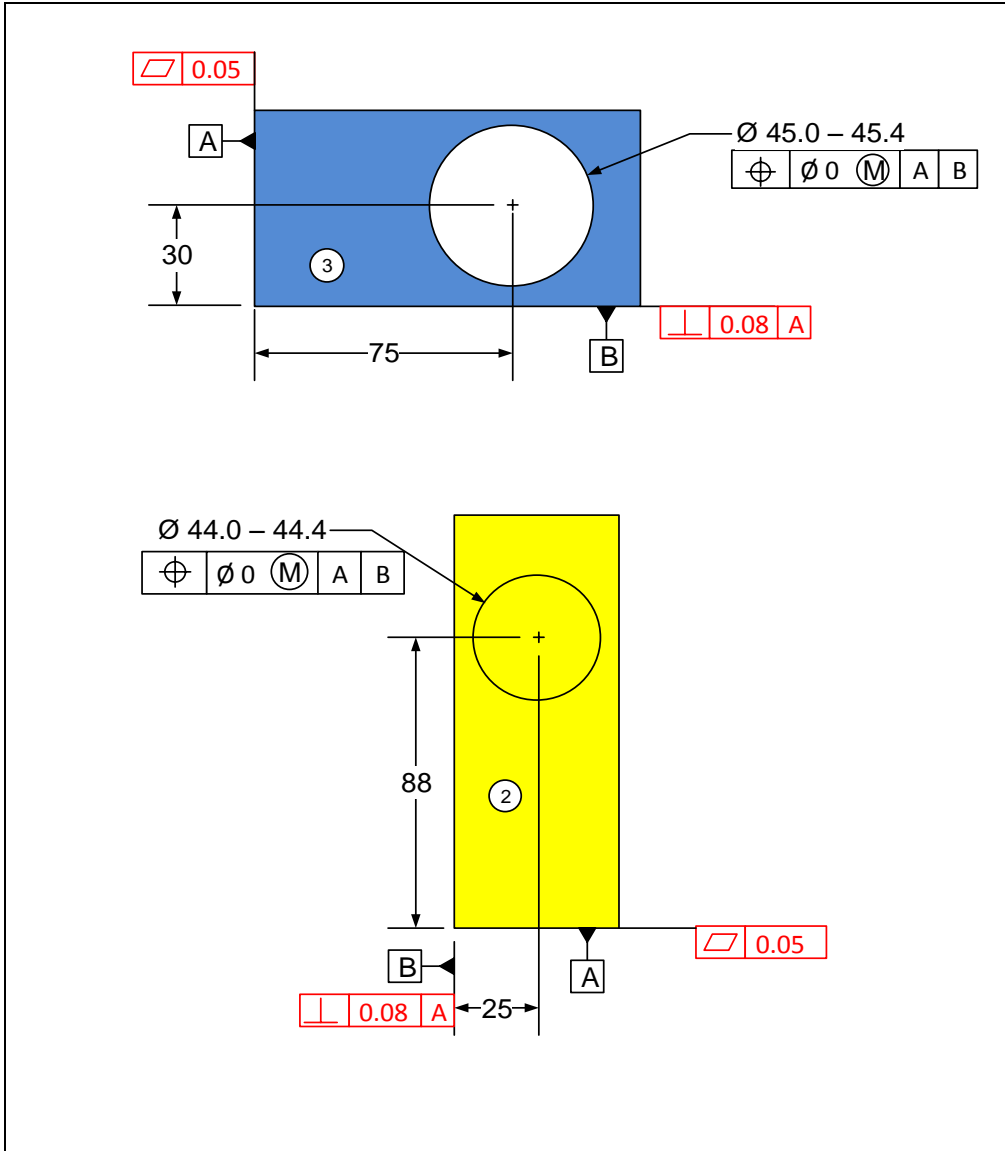


Figure 11-70. Initial tolerances for part<sub>2</sub> and part<sub>3</sub>

### Graphical Method

Figure 11-71 shows the sketch assembly of the problem. The two fit features are modeled at their MMC limit of size. Since the position tolerances are zero at MMC, the actual positions of the fit features match their theoretical positions of 75 mm and 30 mm for the hole and 88 mm and 25 mm for the pin. The surfaces that support the fitting parts are controlled by profile tolerances. The profile-controlled surfaces are set to their maximum values of 50.25 mm for the lower step and 58.125 mm for the upper step. Based on these dimensions, the distance between the centers of the two fit features becomes 0.28 mm. The minimum gap between the two fit feature surfaces becomes 0.02 mm as indicated in the sketch.

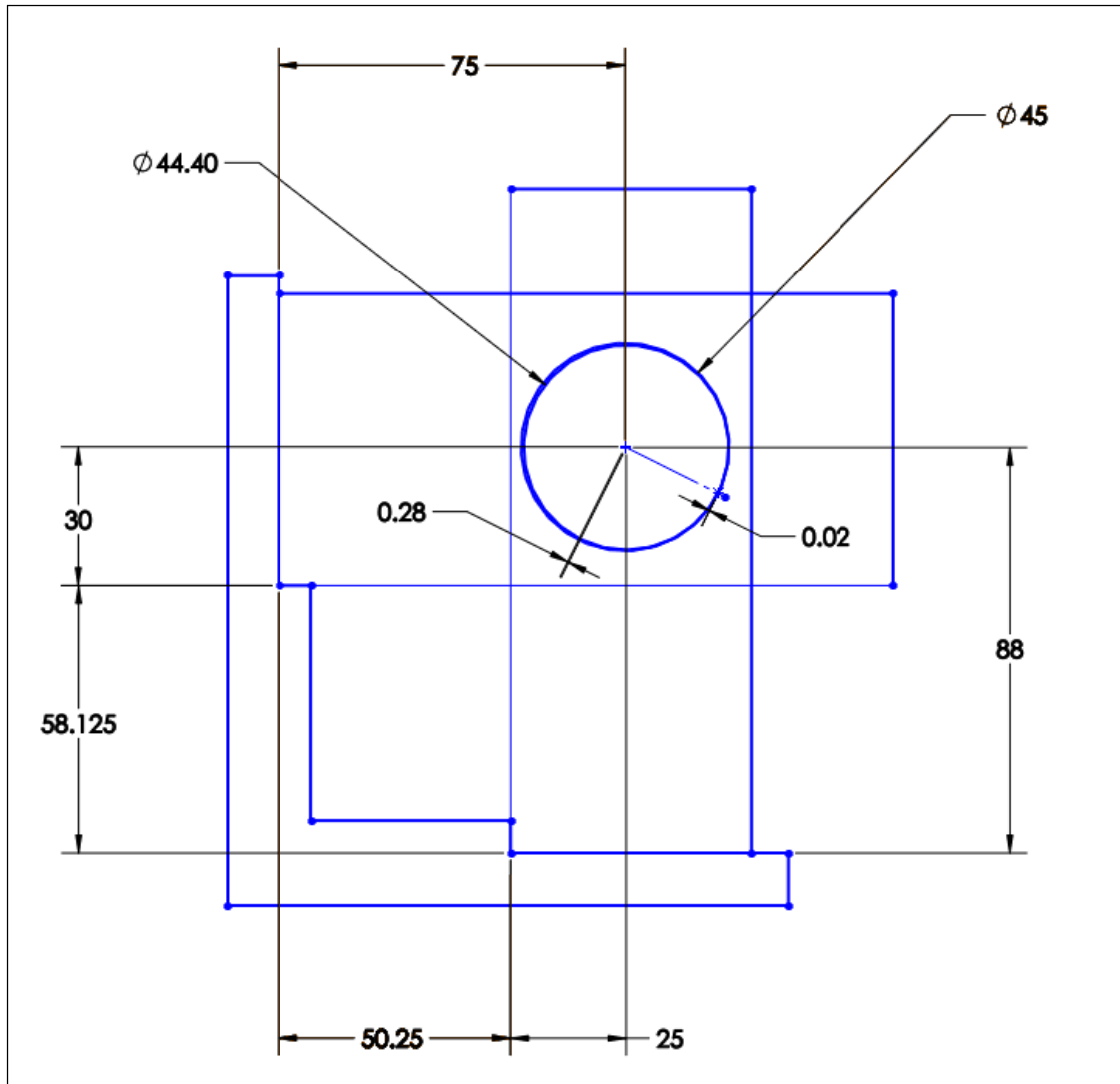
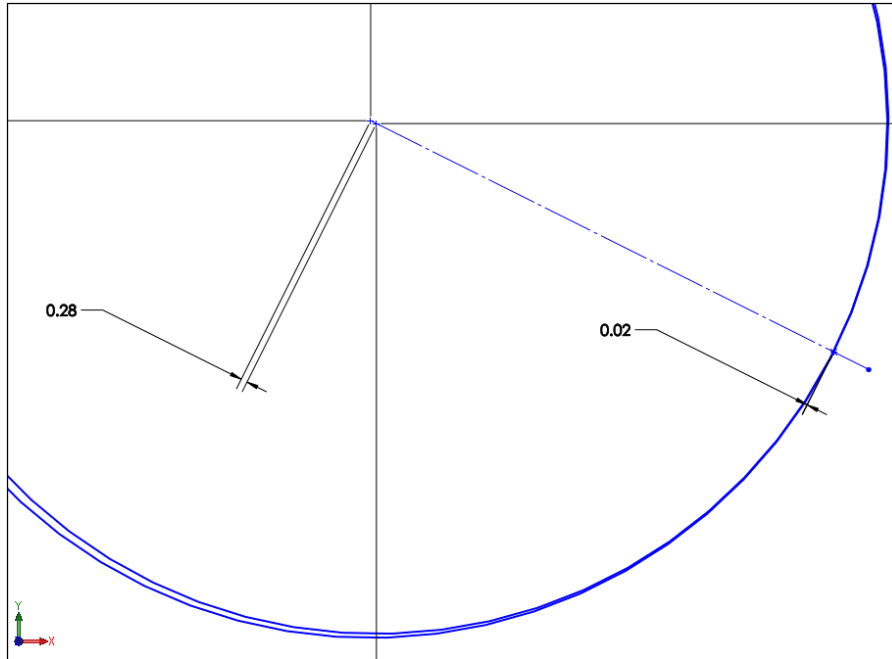


Figure 11-71. The sketch assembly of the problem

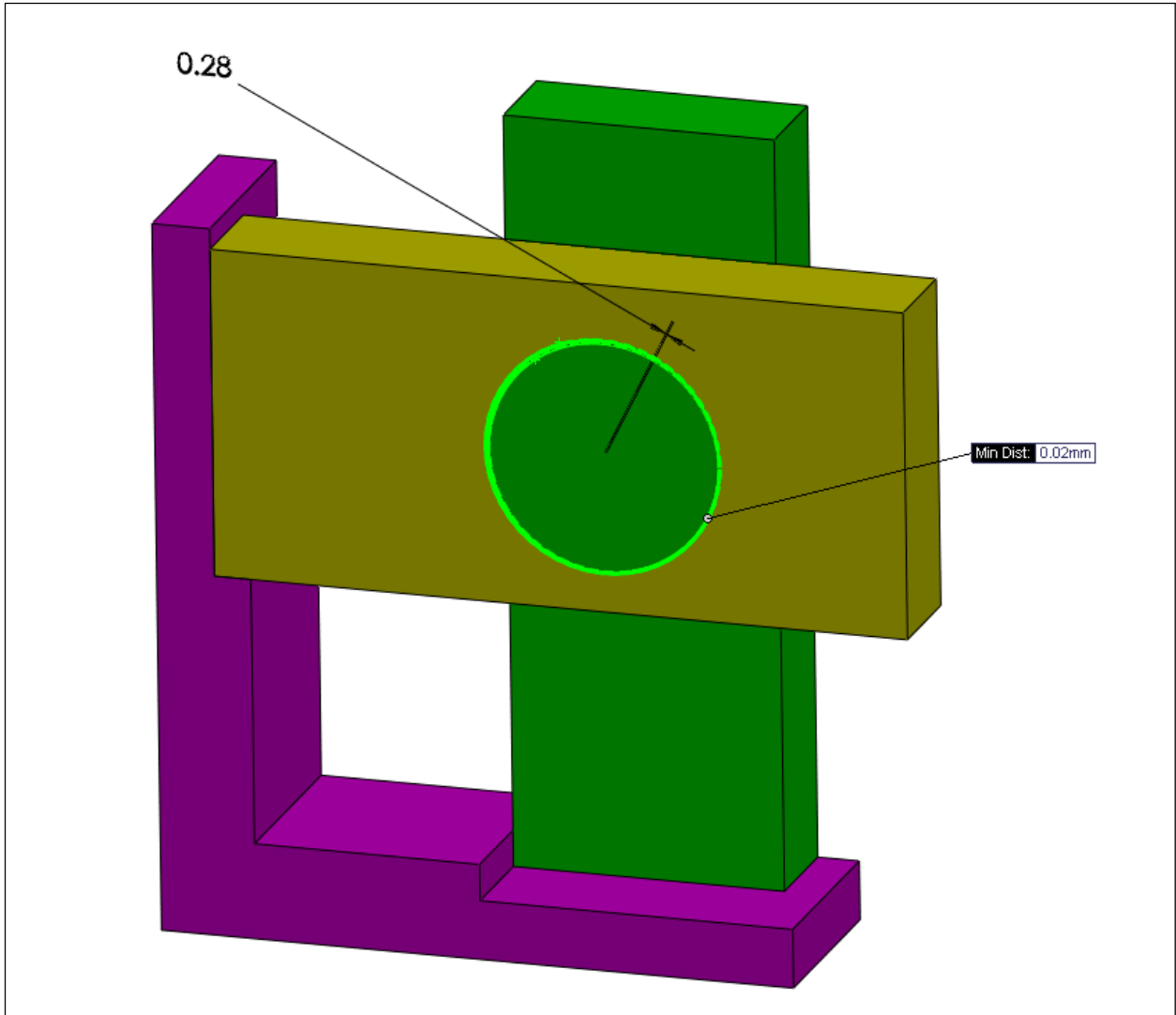
Figure 11-72 shows the detailed view of the fit features and the minimum gap. The minimum gap is located along the line connecting the centers of the fit features.



**Figure 11-72. The resulting minimum gap between the fit features is 0.02 mm**

In order to set the minimum gap to zero we can increase the size of the pin feature by 0.04 mm from 44.4 to 44.44 mm. Note that the gap is a radial dimension while the feature size is a diametrical value.

Figure 11-73 shows the 3D model of the assembly, the minimum gap in the fit and the center distance between the fitting features.



**Figure 11-73.** The 3D model of the assembly showing the distance between the fitting feature centers and the minimum gap value.

The CAD system finds the minimum distance between two circular feature profiles. In this case the gap value of 0.02 mm and the center distance value of 0.28 mm are in agreement with the sketch assembly solution.

#### **Example-11: Analysis of fits with simultaneous fit features**

Figure 11-74 shows a four-part fit assembly that was discussed in Chapter-10. Part4 has a pattern of two holes fitting two boss features of the side parts. Assume the side parts are glued to the bottom plate.

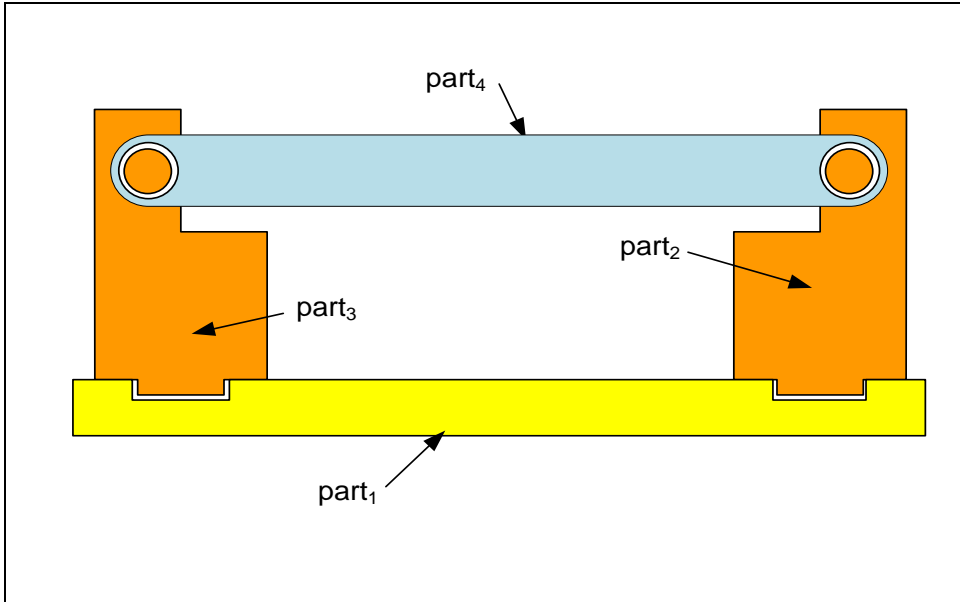


Figure 11-74. A four-part assembly

Figure 11-75 shows the feature and tolerances for part<sub>1</sub>.

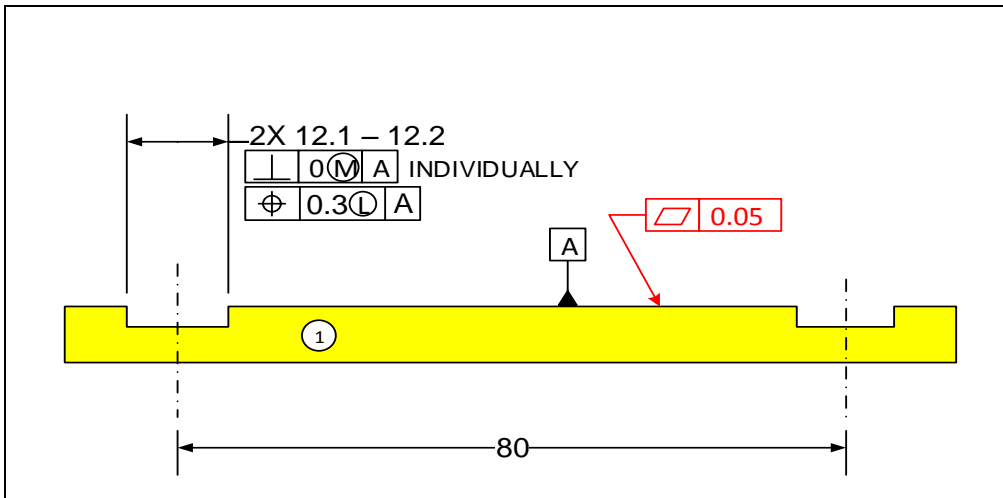


Figure 11-75. Initial tolerances of part<sub>1</sub>

Figure 11-76 shows the feature and tolerances for part<sub>2</sub> and part<sub>3</sub>.

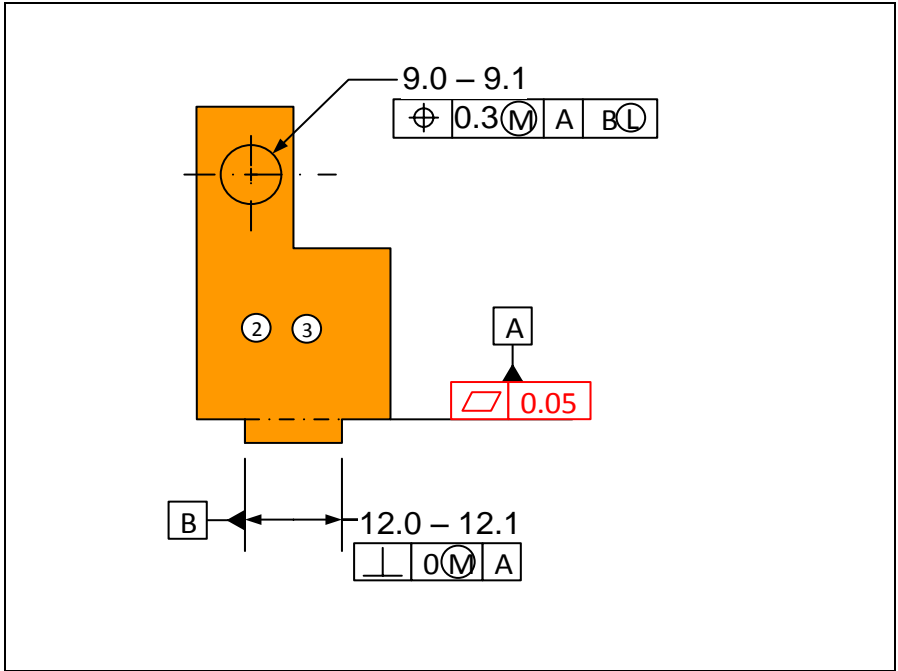


Figure 11-76. Initial tolerances for part<sub>2</sub> and part<sub>3</sub>

Figure 11-77 shows the feature and tolerances for part<sub>4</sub> bar that is placed last into the assembly.

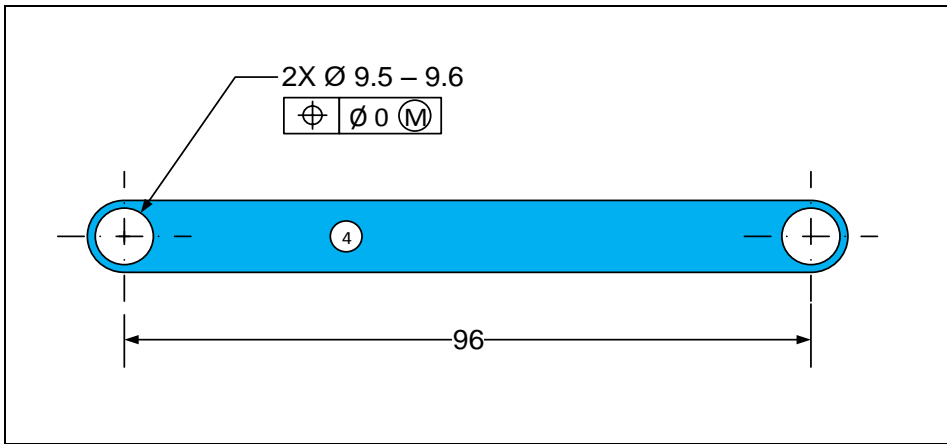


Figure 11-77. Initial tolerances for part<sub>4</sub>

## Graphical Solution

Since the bar has two simultaneous fits, we have to set up the problem such that two gaps are to be checked together. Multiple gap formulations become more complex to solve manually but fortunately such multi-gap problems can often be avoided. In this case we select the hole sizes to be slightly bigger than boss sizes such that each can individually fit to its mating boss. The hole on the right fits first and becomes a constraint for the fit of the hole on the left. We must now analyze the fit of the left hole and the left boss. Figure 11-78 shows the arrangement of parts for fit.

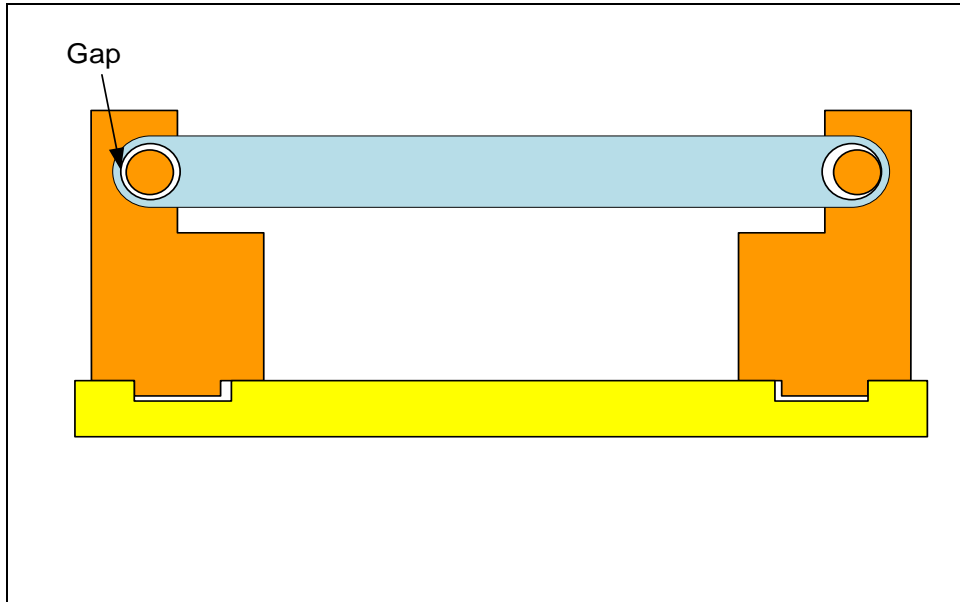


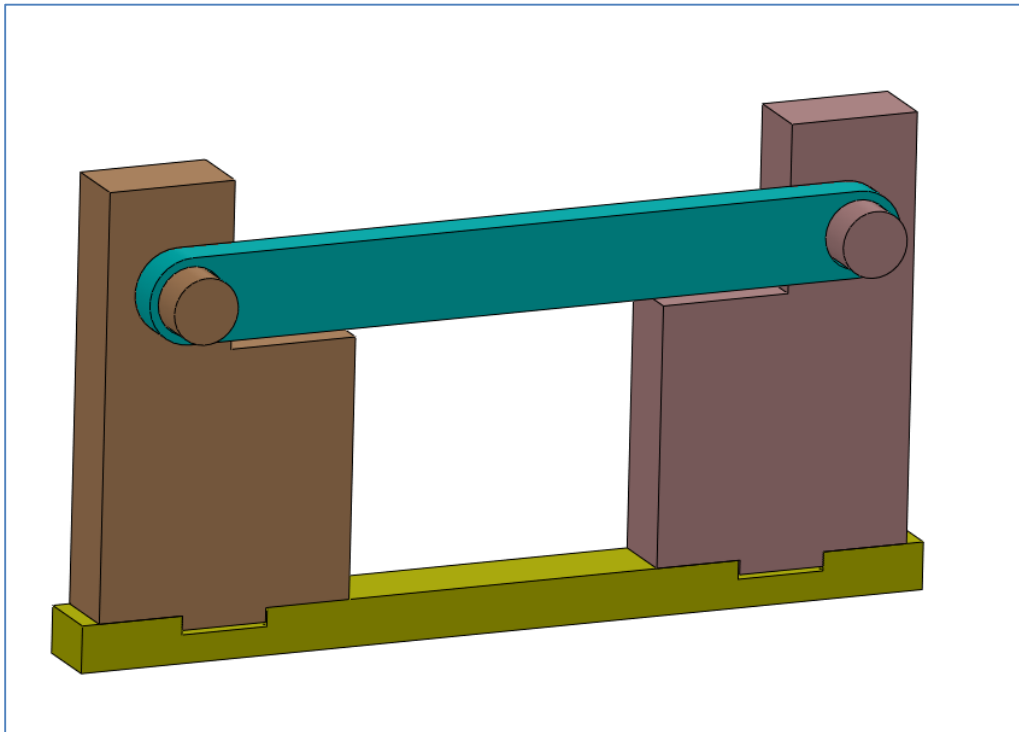
Figure 11-78. Worst-case arrangement of parts for fit

To set up this fit problem graphically for minimum gap check, we can develop the tolerance loop and use that as a guide for setting the dimension limits that minimize the gap. However, in many cases we can intuitively deduce the dimension limits that lead to a minimum gap. In this case we model the features such that the pins are farthest apart and the holes are closest to each other. The slot and rail sizes are modeled at the LMC limit of limit of size. The hole and pin sizes are modeled at their MMC limit of size. The following list summarizes the modeling selections:

- The slots will be modeled at their LMC size limit of 12.2 mm
- The slots will be located at a distance of 0.3 mm larger than the basic distance between the slot center planes.
- The rails will be modeled at their LMC limits of size of 12.0 mm.
- The bosses will be at their MMC limits of size of 9.1 mm.
- The bosses will be located 0.15 mm off their theoretical positions because of the 0.3 mm position tolerance at MMC specification. The right boss is 0.15 mm to the right and the left boss is located 0.15 mm to the left.

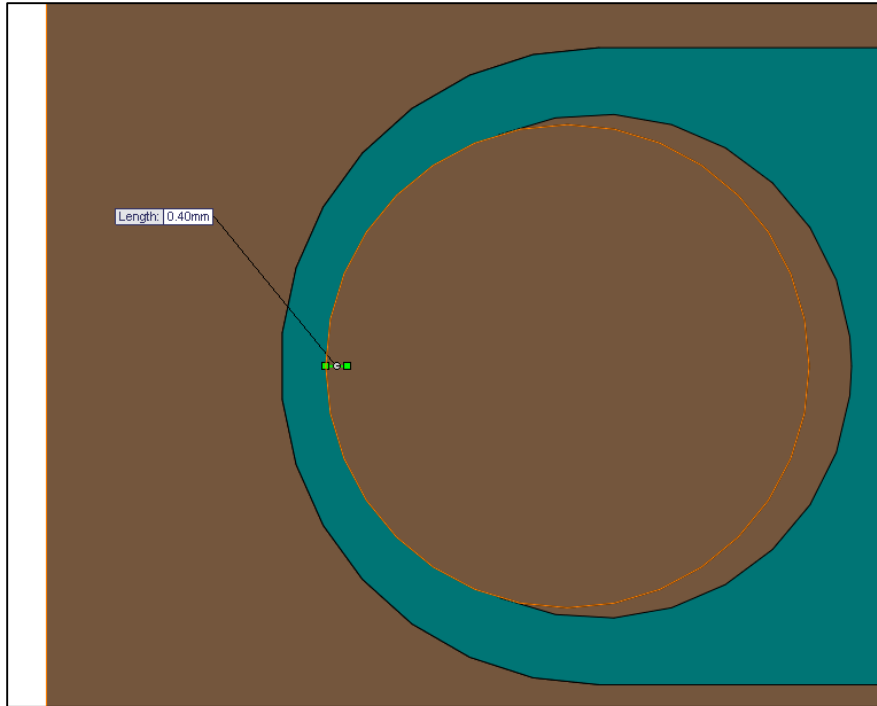
- The holes will be at their MMC limits of size of 9.5 mm
- The holes will be located at their theoretical distance because of the zero position at MMC specification.

Figure 11-79 shows the 3D model of the assembly created with the design dimensions and tolerances.



**Figure 11-79.** The 3D model of the assembly

The assembly is built in the worst-case arrangement where the two side parts are pushed away from each other. The bar's right hole is made tangent to the right boss. The minimum gap is then checked in the left hole/boss fit. Figure 11-80 shows the result of the checking the gap. In this case the minimum gap is actually 0.4 mm of interference.



**Figure 11-80. The minimum gap is 0.4 mm of interference**

In order to set the minimum gap to zero we can increase the size limits of the two holes by 0.4 mm to 9.9 – 10.0 mm.

### **Analytical Solution**

Figure 11-81 shows the tolerance loop for the fit analysis of the gap. There are four pairs of fits numbered one through four. Each fit includes a  $\frac{1}{2}$  H vector and a  $\frac{1}{2}$  F vector. There are also four position dimensions. The F vectors are shown in blue while the H vectors are shown in red.

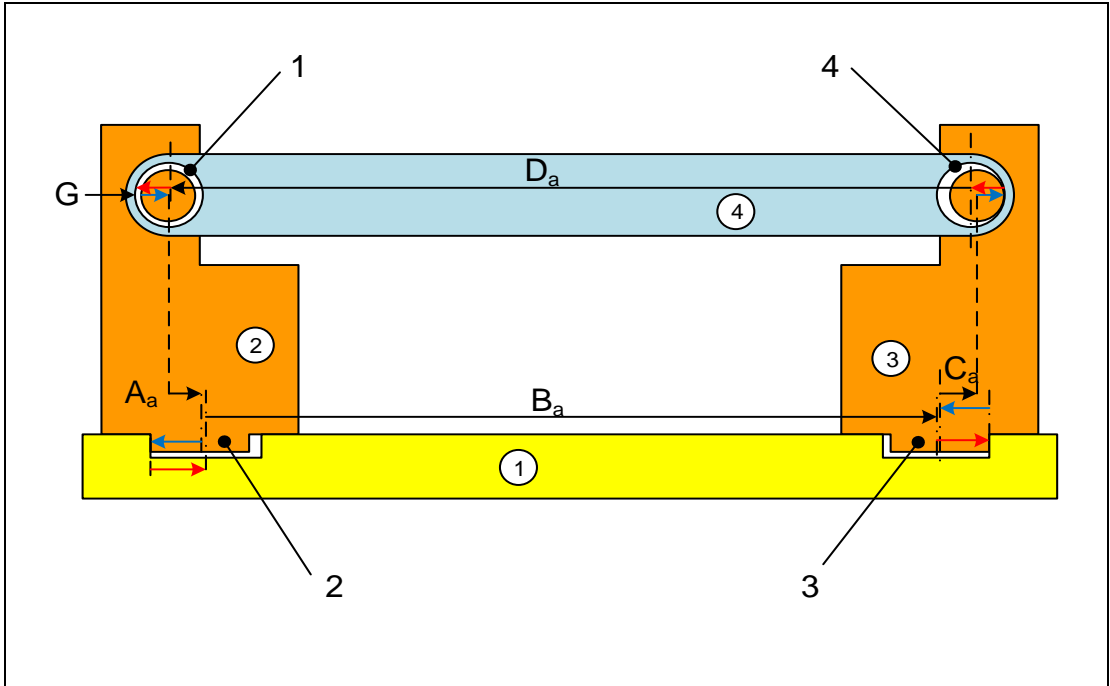


Figure 11-81. The tolerance loop for predicting the minimum gap size

The axes and center planes referenced are the actual axes and center planes.

- $A_a$  : Connects the boss axis to the rail center plane on part<sub>2</sub>
- $C_a$  : Connects the boss axis to the rail center plane on part<sub>3</sub>
- $B_a$  : Connects the center planes of the rails on part<sub>1</sub>
- $A_a$  : Connects the axes of the two holes on part<sub>4</sub>

The gap expression can be developed by simply following the arrows as they start from the head of the gap vector going around the loop ending at the tail of the gap vector

$$G + (\frac{1}{2} F_{1a} + A_a) - \frac{1}{2} F_{2a} + (\frac{1}{2} H_{2a} + B_a + \frac{1}{2} H_{3a}) - \frac{1}{2} F_{3a} + (C_a + \frac{1}{2} F_{4a}) - (\frac{1}{2} H_{4a} + D_a + \frac{1}{2} H_{1a}) = 0$$

The minimum gap expression is

$$G_{min} = (\frac{1}{2} H_{4a} + D_a + \frac{1}{2} H_{1a})_{min} - (C_a + \frac{1}{2} F_{4a})_{max} - (\frac{1}{2} H_{2a} + B_a + \frac{1}{2} H_{3a})_{max} - (\frac{1}{2} F_{1a} + A_a)_{max} + (\frac{1}{2} F_{2a})_{min} + (\frac{1}{2} F_{3a})_{min}$$

The holes have zero position at MMC specification, therefore

$$(\frac{1}{2} H_{4a} + D_a + \frac{1}{2} H_{1a})_{min} = \frac{1}{2} (9.5) + 96 + \frac{1}{2} (9.5) = 105.5$$

The pins have 0.3 mm position tolerance at MMC

$$(C_a + \frac{1}{2} F_{4a})_{max} = 8 + \frac{1}{2} (0.3) + \frac{1}{2} (9.1) = 12.7$$

$$(\frac{1}{2} F_{1a} + A_a)_{max} = 8 + \frac{1}{2} (0.3) + \frac{1}{2} (9.1) = 12.7$$

The slots have 0.3 mm position tolerance at LMC

$$(\frac{1}{2} H_{2a} + B_a + \frac{1}{2} H_{3a})_{max} = \frac{1}{2} (12.2) + (80 + 0.3) + \frac{1}{2} (12.2) = 92.5$$

The minimum gap becomes

$$G_{min} = 105.5 - 12.7 - 92.5 - 12.7 + \frac{1}{2} (12) + \frac{1}{2} (12) = -0.4 \text{ mm}$$

The result agrees with the graphical solution.

Figure 11-82 shows the TAP results for the final dimensions that lead to the minimum gap of zero. The gap expression is

$$G = (\frac{1}{2} H_{4a} + D_a + \frac{1}{2} H_{1a}) - (C_a + \frac{1}{2} F_{4a}) - (\frac{1}{2} H_{2a} + B_a + \frac{1}{2} H_{3a}) - (\frac{1}{2} F_{1a} + A_a) + (\frac{1}{2} F_{2a}) + (\frac{1}{2} F_{3a})$$

The basic position dimensions sum up to zero and are not entered as an input vector

$$M = D - C - B - A = 96 - 8 - 80 - 8 = 0$$

The simplified gap expression has the following terms

$$G = \frac{1}{2} H_{4a} + \frac{1}{2} H_{1a} - \frac{1}{2} F_{4a} - \frac{1}{2} H_{2a} - \frac{1}{2} H_{3a} - \frac{1}{2} F_{1a} + \frac{1}{2} F_{2a} + \frac{1}{2} F_{3a}$$

The data for these terms are then entered in the program in the order they appear above.

The screenshot shows the 'Tolerance Analysis' window. It contains a table with the following columns: Vector Type, Coefficient, Minimum (L), Maximum (W), Tol Type, Tol Value, and Qualifier. The table has 10 rows of data. To the right of the table, there are checkboxes for 'Minimum gap' (checked, value 0.000) and 'Maximum gap'. Below that is a 'Statistical Analysis' section with a text input for 'Enter Percentile between 0 and 100' (value 99.9), and fields for 'Min gap' (value 0.230) and 'Max gap'. A 'Calculate' button is located below the statistical section. At the bottom left, there is a 'Save or Load Model' section with 'Save Model' and 'Load Model' buttons and a text input field containing 'Example26'.

Vector Type	Coefficient	Minimum (L)	Maximum (W)	Tol Type	Tol Value	Qualifier
Size - Internal	0.5	9.9	10	Position	0	M
Size - Internal	0.5	9.9	10	Position	0	M
Size - External	-0.5	9.0	9.1	Position	0.3	M
Size - Internal	-0.5	12.1	12.2	Position	0.3	L
Size - Internal	-0.5	12.1	12.2	Position	0.3	L
Size - External	-0.5	9.0	9.1	Position	0.3	M
Size - External	0.5	12	12.1	Form/Orient	0	M
Size - External	0.5	12	12.1	Form/Orient	0	M
	1	20	21	Position	0.1	M
	1	20	21	Position	0.1	M

Figure 11-82. The result of TAP worst-case analysis and statistical simulation

## Exercise Problems

### Problem-1

Consider the three part assembly shown in Figure 11-83. Model these parts in a CAD system and dimension and tolerance the parts to be suitable to achieve a precision gap performance. For reference, use 100 mm for the width of slot in part<sub>3</sub>. The rest of the dimensions are up to you. The gap is to be between 1 mm and 1.25 mm. Assume precisions to be consistent with milling processes. Only specify tolerance statements relevant to the three-part fit. Use both graphical and analytical methods to set  $G_{min}=1$  mm. If necessary, only modify the width dimension of part<sub>3</sub>. Check the resulting maximum gap against 1.25 mm limit. If the gap exceeds 1.25 mm, reduce the tolerances and solve the problem again with reduced tolerance values. Verify the final results with TAP.

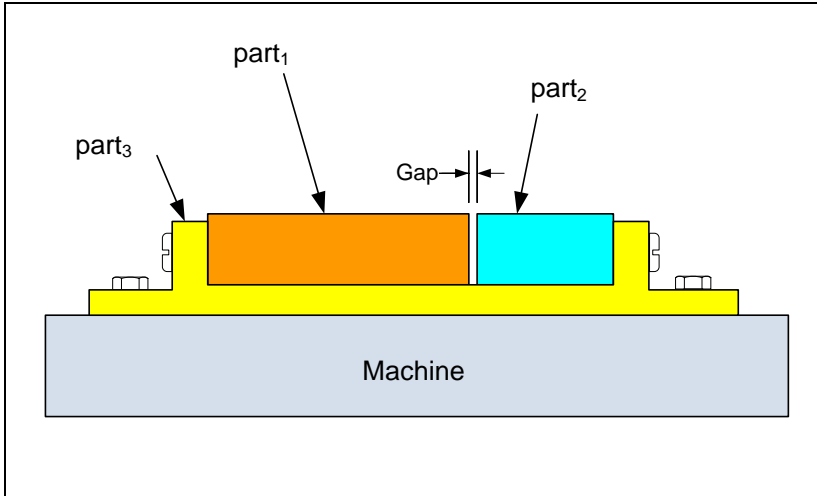


Figure 11-83. The simple multipart assembly of Problem-1

### Problem-2

Consider the three part assembly shown in Figure 11-84. Model these parts in your CAD system and dimension and tolerance the parts to be suitable to achieve a precision gap performance. For reference, use 100 mm for the width of slot in part<sub>1</sub>. The rest of the dimensions are up to you. The minimum gap is to be zero. Assume precisions to be consistent with milling processes. Only specify tolerance statements relevant to the three-part fit. Use both graphical and analytical methods to set  $G_{\min}=0$  mm. If necessary only modify the width dimension of part<sub>1</sub>. Tolerances do not need to be altered. Check the resulting maximum gap.

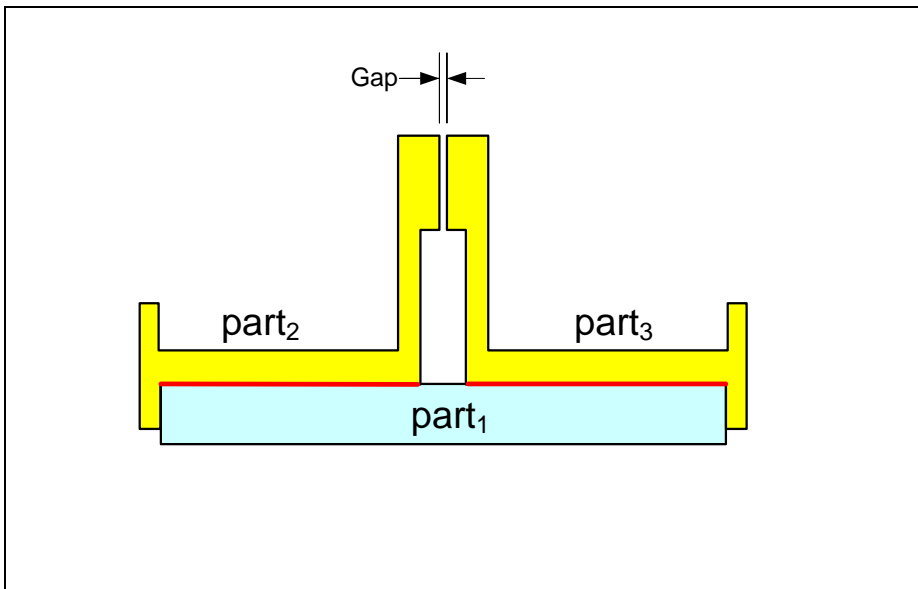


Figure 11-84. The assembly of Problem-2

### Problem-3

Consider the three part assembly shown in Figure 11-85. Model these parts in your CAD system and dimension and tolerance the parts to be suitable to achieve a precision gap performance. For reference, use 100 mm for the distance between the two slots in part<sub>1</sub>. The rest of the dimensions are up to you. The minimum gap is to be zero. Assume precisions to be consistent with milling processes. Specify tolerance statements relevant to the three-part fit and those necessary for fixed fasteners. Use both graphical and analytical methods to set  $G_{\min}=0$  mm. If necessary only modify the theoretical distance between the slot center planes in part<sub>1</sub>. Do not change the tolerance values. Check the resulting maximum gap.

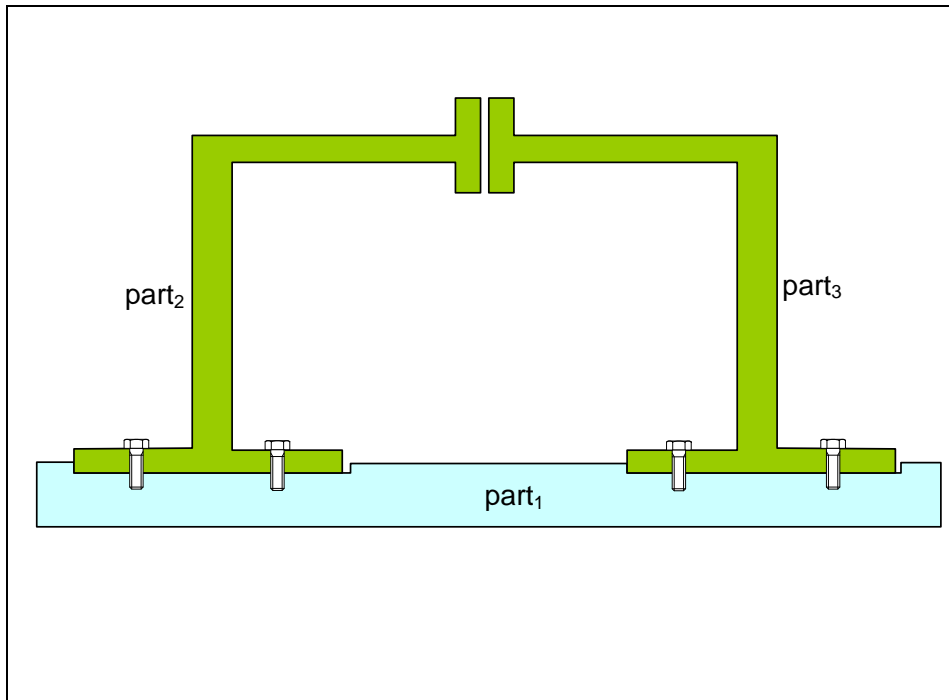


Figure 11-85. The assembly of Problem-3

### Problem-4

Consider the three part assembly shown in Figure 11-86. Model these parts in your CAD system and dimension and tolerance the parts to be suitable to achieve a precision gap performance. For reference, use 200 mm for the length of parts with the T-shaped cross-section. The rest of the dimensions are up to you. The loose bolts are to assemble without interference. Assume precisions to be consistent with milling processes. Use graphical method. If necessary only modify the theoretical distances. Tolerances do not need be altered. Check the resulting maximum gap.

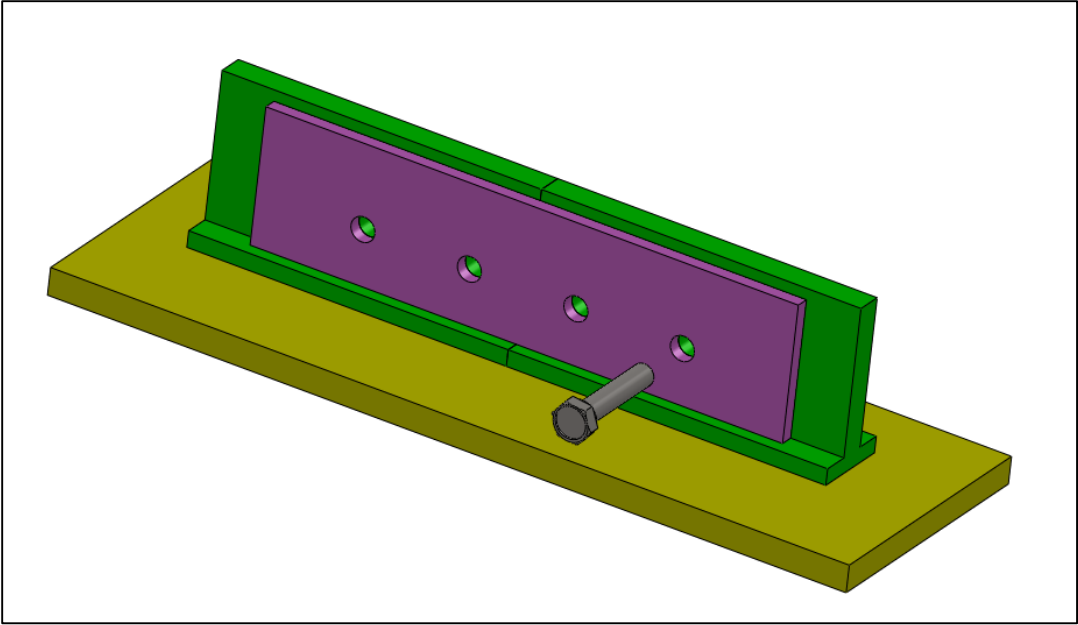


Figure 11-86. The assembly of Problem-4

## INDEX

### A

<i>actual mating envelope</i> .....	63
Angularity .....	70
<i>arrangement</i> .....	370

### B

<i>bonus tolerance</i> .....	168
------------------------------	-----

### C

Circularity .....	56
Cylindricity .....	58

### D

<i>datum feature simulators</i> .....	59
<i>datum features</i> .....	59
Dimensional tolerances .....	46

### F

feature .....	16
features-of-size .....	46
<i>fit boundaries</i> .....	156
<i>fit formula</i> .....	162
<i>fixed fastener formula</i> .....	270
Flatness .....	50
<i>floating fastener formula</i> .....	273

### G

Geometric tolerances .....	47
----------------------------	----

### I

<i>independency symbol</i> .....	226
----------------------------------	-----

### M

<i>maximum play formula</i> .....	162
-----------------------------------	-----

### O

<i>orientation-constrained actual mating envelope</i> .....	217
---	-----

### P

Parallelism .....	61
Perpendicularity .....	67
<i>presumed order of assembly</i> .....	297
<i>primary orienting datum surface</i> .....	230
<i>projected tolerance zone</i> .....	269

### R

<i>regardless of feature size (RFS)</i> .....	167
---	-----

### S

<i>secondary orienting/locating surface</i> .....	230
---	-----

<i>staging</i> .....	62
Straightness.....	55
<b>T</b>	
Tolerances of form.....	50
Tolerances of orientation.....	59
<b>U</b>	
unconstrained <i>actual mating envelope</i> .....	63
<b>V</b>	
<i>virtual boundaries</i> .....	158

