

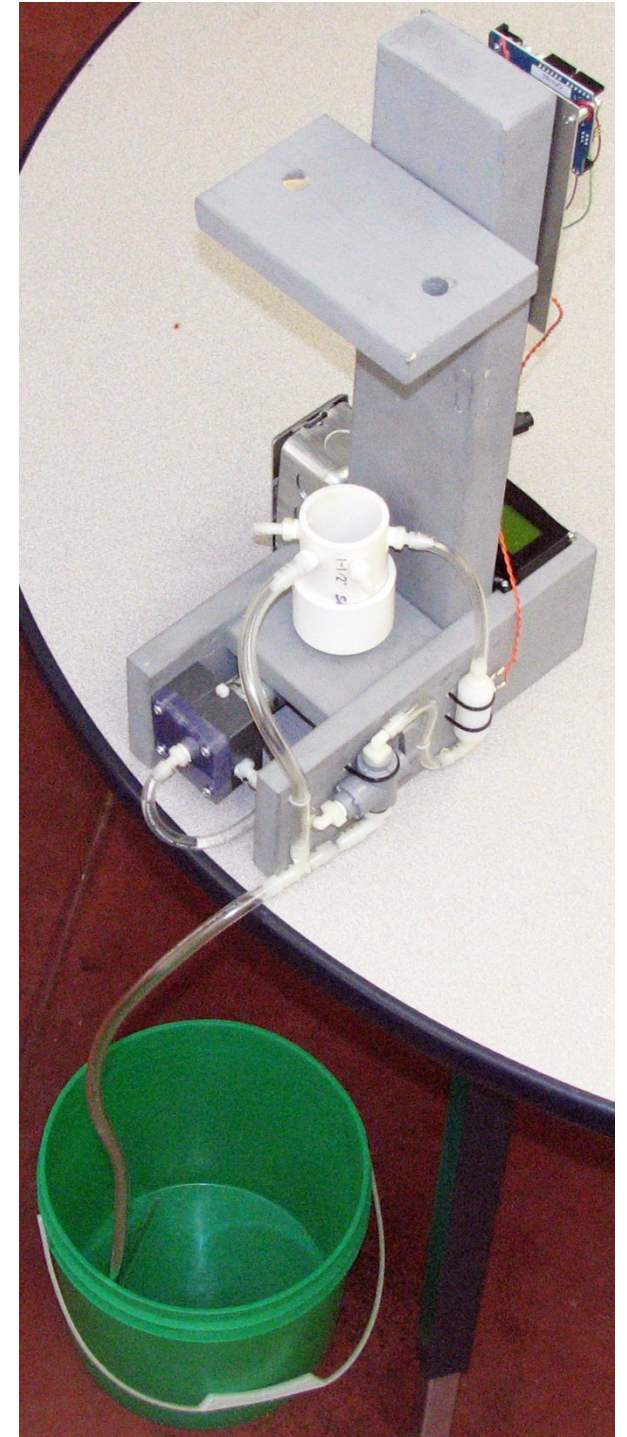

# Calibration of Conductivity Sensors

EAS 199B





cal · i · brate [kal-uh-breyt]

*-verb (used with object), -brat · ed, -brat · ing.*

1. to determine, check, or rectify the graduation of (any instrument giving quantitative measurements).

# Calibration

- Associate sensor output with salt concentration
- Relate sensor output and salt concentration using an equation (linear regression)
- The goal is to be able to compute the salt concentration based on sensor output

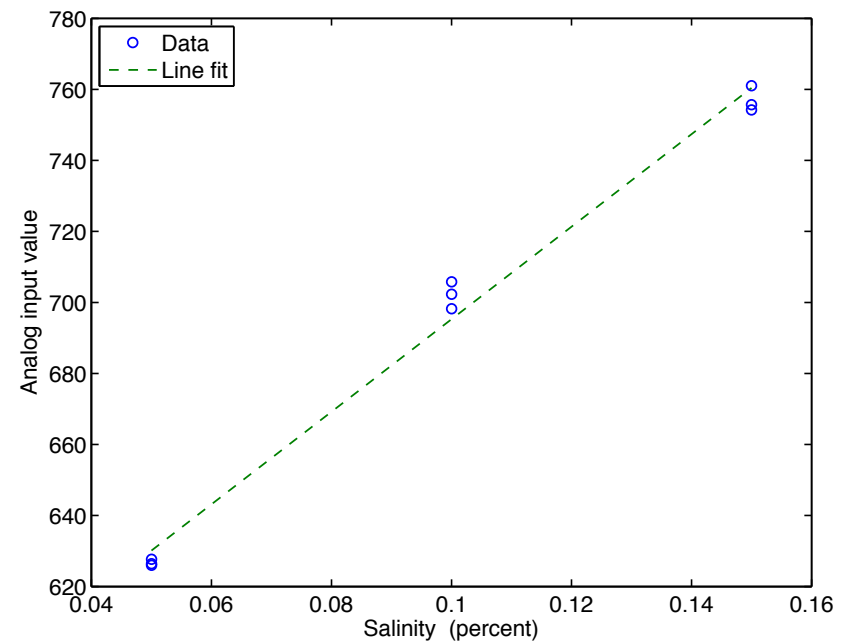



# The Basic Idea

- Adding salt to the water will increase the availability of  $\text{Cl}^-$  ions at the anode
- More ions at the anode will increase the rate at which chemical reactions can occur
- The “electrical resistance” of the salt water will decrease as more salt is added to the water
- The analog voltage on the + side of the  $10\text{k}\Omega$  resistor will increase as more salt is added
- Correlating this voltage with the salt concentration will allow us to “calibrate” the conductivity sensor

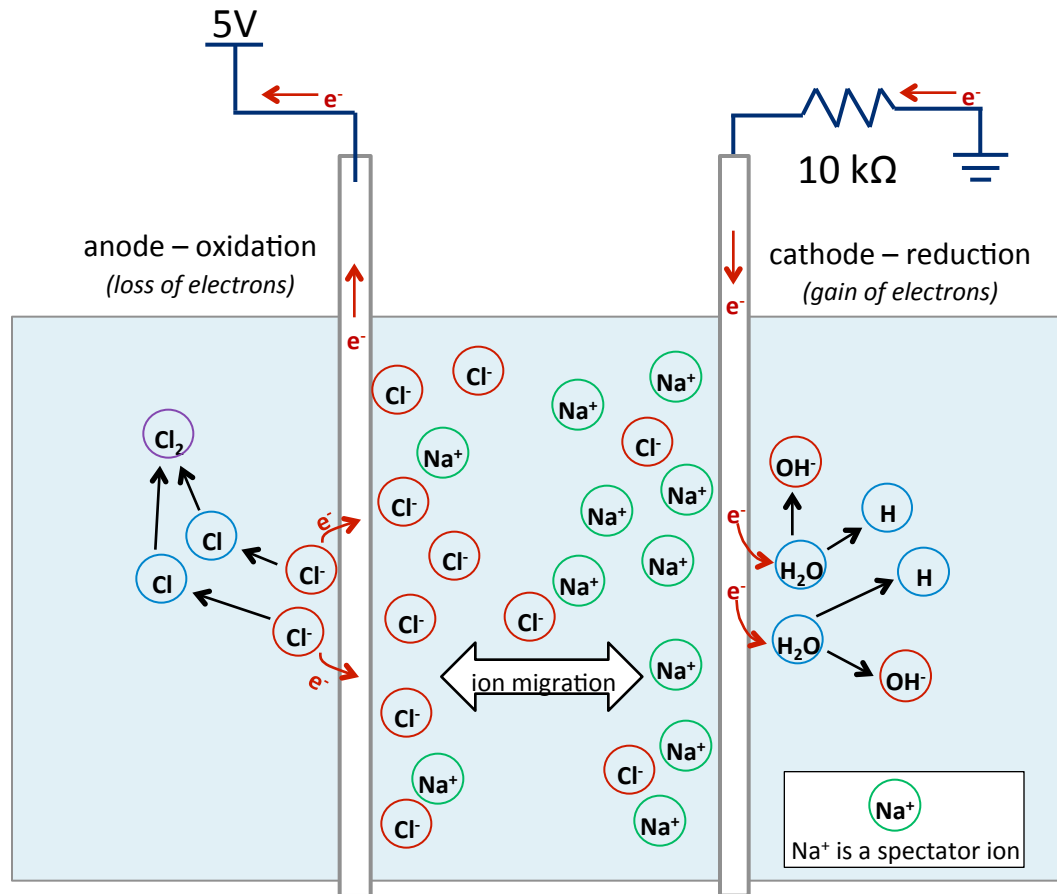



# The Circuit and Sketch

```
int salinity_power_pin = 4; // Digital I/O pin, Global variable

void setup()
{
  Serial.begin(9600);
  pinMode(power_pin, OUTPUT);
}

void loop()
{
  int salinity_input_pin = 2; // Analog input pin
  int salinity;

  salinity = salinity_reading( salinity_power_pin, salinity_input_pin );
  Serial.println(salinity);
}
// -----
int salinity_reading( int power_pin, int input_pin ) {

  int reading;

  digitalWrite( power_pin, HIGH ); // Turn on the sensor
  delay(10); // Wait to settle
  reading = analogRead( input_pin ); // Read voltage
  digitalWrite( power_pin, LOW ); // Turn off the sensor
  return reading;
}
```

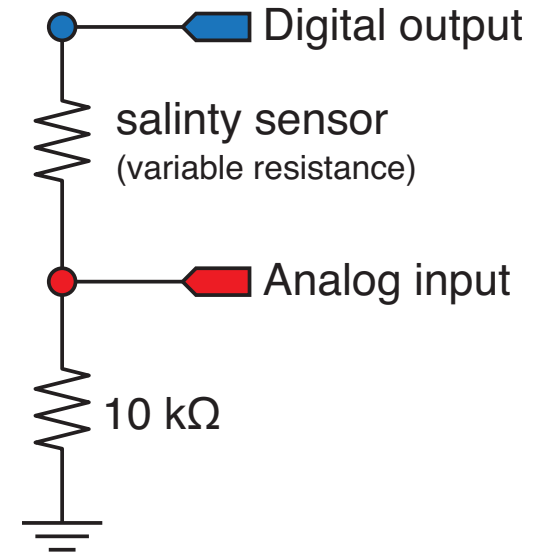



# Salt Concentrations

- Each group of students should put about 1.5 inches of water in four bottles
- The four bottles should contain . . .
  - DI water
  - 0.05% weight NaCl
  - 0.10% weight NaCl
  - 0.15% weight NaCl
- Please take **ONLY** the amount that you will need to use **TODAY**
- Be sure to label your water bottles
- Swish a small amount of DI water around in your bottle to wash out impurities before filling with calibration water

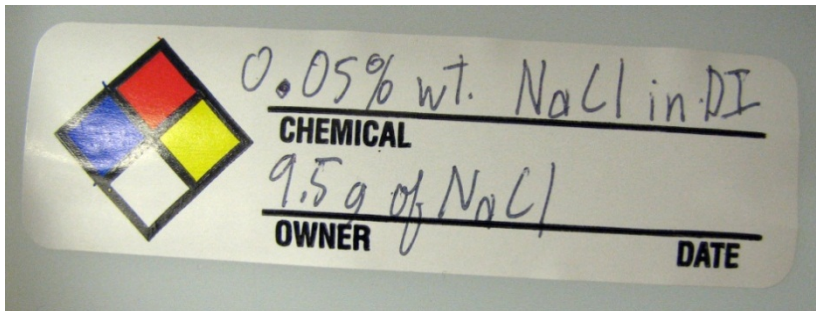



# Capture data during calibration

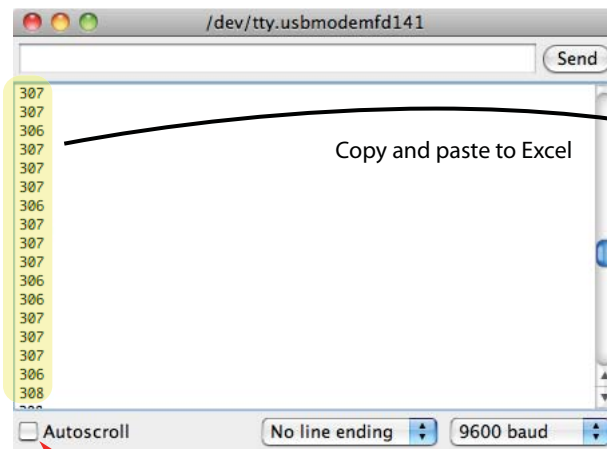

Click the Autoscroll button to temporarily suspend updates to the screen. This is helpful when manually copying data to another application.

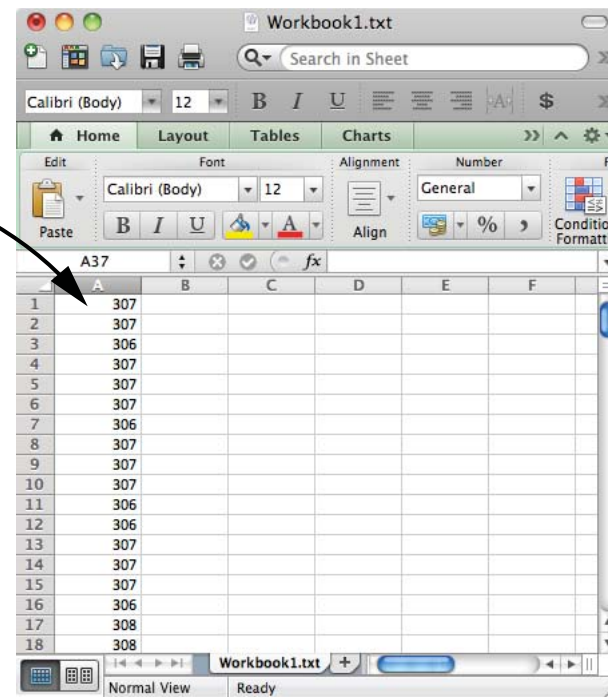



# Calibration steps in the lab

1. Configure your flow loop as required for homework
2. Implement the conductivity sensor circuit on your breadboard
3. Flush tank with DI water.
  - a. Pour enough DI water into your fishtank to fill the flow loop
  - b. Turn on the pump to run the flow loop for about a minute to “wash out” the impurities.
  - c. Turn the three-way valve toward the drain to flush the system
  - d. Repeat to completely clean the system
4. Fill the system with DI water
5. Collect calibration data
  - a. Wait for the system to come into equilibrium
  - b. Copy a large (50 to 100) readings from the Serial Monitor to a text file or Excel
  - c. Save the file with a name that allows you to identify it later
6. Fill the system with 0.05 wt% salt water. Flush once, and refill with 0.05 wt% salt water
7. Repeat steps 5a through 5c
8. Repeat steps 5 through 7 for 0.10 wt% salt water and 0.15 wt% salt water



# Analysis of calibration data

1. Use MATLAB to create a histogram of your data
2. Compute the mean, standard deviation and median of the data
3. Record the data in the following table

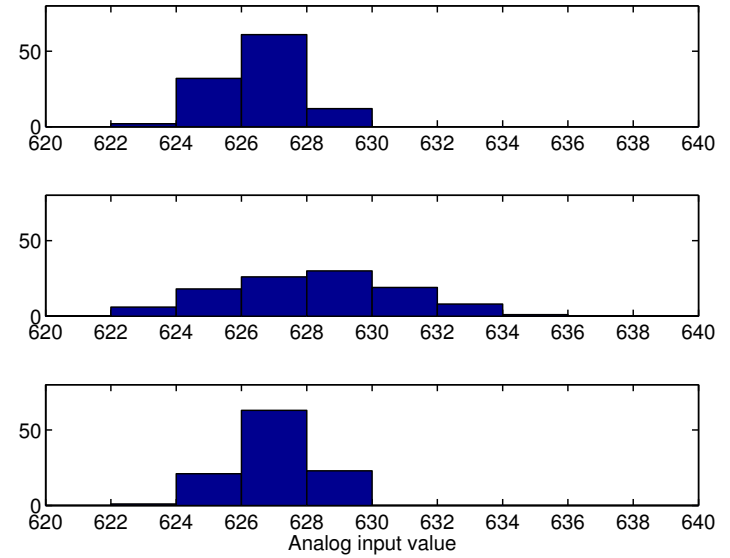

Wt% NaCl	n	Mean	Standard deviation	Median
0				
0.05				
0.10				
0.15				





# Steps

1. Configure your flow loop as required for homework
2. Implement the conductivity sensor circuit on your breadboard
3. Flush tank with DI water.
  - a. Pour enough DI water into your fishtank to fill the flow loop
  - b. Turn on the pump to run the flow loop for about a minute to “wash out” the impurities.
  - c. Turn the three-way valve toward the drain to flush the system
  - d. Repeat to completely clean the system
4. Fill the system with DI water
5. Collect calibration data for DI water
6. Fill the system with 0.05 wt% salt water. Flush once, and refill with 0.05 wt% salt water
7. Collect calibration data for 0.05wt% salt water
8. Repeat steps 6 and 7 for 0.10 wt% salt water and 0.15 wt% salt water

salt concentration (%wt)	output to LCD
0.00	
0.05	
0.10	
0.15	

← collect this data



# Fit Output of Sensor to Salt Concentration

