

Enabling Technologies and Architectures for 5G Wireless

Shilpa Talwar, Debabani Choudhury, Konstantinos Dimou, Ehsan Aryafar, Boyd Bangerter, Kenneth Stewart
Intel Corporation, Santa Clara, CA

Abstract — The proliferation of smart devices and the resulting exponential growth in data traffic has increased the need for higher capacity wireless networks. The cellular systems industry is envisioning an increase in network capacity by a factor of 1000 over the next decade to meet this traffic demand. In addition, with the emergence of Internet of Things (IoT), billions of devices will be connected and managed by wireless networks. Future networks must satisfy the above mentioned requirements with high energy efficiency and at low cost. Hence, the industry attention is now shifting towards the next set of innovations in architecture and technologies that will address capacity and service demands envisioned for 2020, which cannot be met only with the evolution of 4G systems. These innovations are expected to form the so called fifth generation wireless communications systems, or 5G. Candidate 5G solutions include i) higher densification of heterogeneous networks with massive deployment of small base stations supporting various Radio Access Technologies (RATs), ii) use of very large Multiple Input Multiple Output (MIMO) arrays, iii) use of millimeter Wave spectrum where larger wider frequency bands are available, iv) direct device to device (D2D) communication, and v) simultaneous transmission and reception, among others. In this paper, we present the main 5G technologies. We also discuss the network and device evolution towards 5G.

Index Terms — 5G technologies and architectures, small cells, HetNets, mmWave, full duplex, massive MIMO, D2D.

I. INTRODUCTION

The dramatic growth in the number of smartphones, tablets, wearables, and other data consuming devices, coupled with enhanced applications are expected to use up the extra capacity from additional spectrum and higher spectral efficiency of 4G systems. According to estimates presented in [1] and [2], such increase in data rates is expected to continue in the coming years and around 2020, the cellular networks might need to deliver as much as 1000 times the capacity relative to current commercial cellular systems. In parallel, there is a strong drive from every industry sector including utility companies, car and manufacturing industries, as well as health and education sectors to exploit the benefits of wireless connectivity. Such evolution, combined with the proliferation of wearable wireless devices, will make the Internet of Things (IoT) a reality. As per one estimate presented in [3], perhaps as many as 50 billion devices will be connected around 2020. These wireless devices are going to have very diverse characteristics in terms of RF hardware, baseband processing capabilities, and overall platform form factor and cost. Consequently, the nature of applications is also going to be diverse in terms of data rates and latency requirements. As an example, in low cost sensor communication applications a few hundreds of bits are reported occasionally to a central node without any latency requirement; on the other hand, there are applications involving high-end computing machines performing

tasks that require very high data rates in the order of several hundreds of Mbytes per second and one way latency in the order of a few milliseconds. Hence, the technical challenges to be addressed in the 5G system design are many fold and unprecedented.

There are several activities around the world to capture the applications and requirements for 5G. Some of the main requirements are summarized below [5, 6].

- 100-1000 times higher system capacity,
- User data rates in the order of Gbps everywhere,
- Latency in the order of 1 millisecond
- 10-100 higher number of connected devices per area
- 10 times longer battery life for devices

Together, these requirements will dramatically transform the wireless experience of a user in a 5G system by offering fast pervasive connectivity anytime, anywhere, to any device.

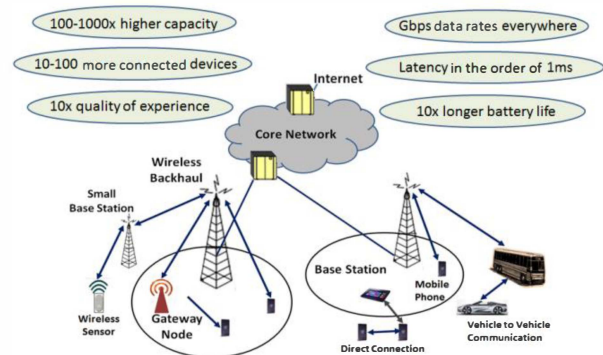

Fig. 1 5G Landscape and performance requirements.

Fig. 1 shows the 5G communications system landscape, which includes heterogeneous network infrastructure, wireless backhaul, multi-radio gateways and direct device-to-device communications. In order to address the 5G requirements discussed above, research on both the device side, as well as on the network side is needed. Devices have to be able to transmit and receive higher data rates at lower or equal cost as the devices of today, and the network has to be able to integrate and manage heterogeneous network elements in a seamless way to provide optimum service experience.

Primary technologies addressing the requirement for higher system capacity and data rates are i) densification of existing networks with the massive addition of small base stations most of them supporting more than one Radio Access Technology (RAT) ii) Massive MIMO schemes, iii) Millimeter-wave (mm-wave) spectrum usage, iv) enhanced direct device to device (D2D) connectivity as well as v) simultaneous transmission and reception (STR). Simultaneous transmission and reception work is expected to play a significant role in the latency reduction as well. Efficient integration of multi-RAT small base stations is going to contribute to the target of higher number of connected

devices. Section II highlights the characteristics of the main candidate features for 5G systems, and Section III describes a high level network architecture accommodating these different features. Section IV highlights the main challenges for wireless devices in the 5G era.

II. ENABLING TECHNOLOGIES

Denser Multi-RAT HetNet: Work in the densification of heterogeneous networks with the massive deployment of small cells has started already in the context of 4G systems. Even denser deployments are anticipated for 5G in order to meet the higher capacity and data rate requirements. It is expected that LTE small base stations will be augmented with WiFi capability, creating rich opportunity for intelligently combining and aggregating the capacity and coverage available across the two protocols. As shown in Tables I and II, significant gain in average cell and cell-edge throughput is possible with multi-radio small cells compared to LTE-only small cells in a typical deployment with 4 outdoor small cells (pico cells) per macrocell [7]. Further, radio access technologies such as a new RAT for mmWave spectrum systems, or other short range RATs, such as the evolution of Bluetooth, or WiFi, or ZigBee used for the communication of sensors and wearable devices might be supported by the single network node (gateway) in parallel to LTE. Efficient RAT association mechanisms are crucial for the smooth interworking among RATs. In addition, inter-RAT handovers should be seamless and fast. The high number of different RATs and the existence of a very high number of users in the system make this requirement more stringent. A very high level of interference and prohibitively high amount of unnecessary signaling can be generated due to inappropriate RAT association and inter-RAT handover decisions. In deployments where capacity is aggregated across RAT's, optimized partitioning of common resources is also going to be crucial. Multi-RAT Hetnets are expected to contribute to 5G target on the number of connected devices, and higher service rates per user.

Massive MIMO: Advanced MIMO techniques are at the heart of achieving higher spectral efficiency for cellular systems. Multi-User MIMO (MU-MIMO) offers increased multiplexing gains and, even though it has been included in the 3GPP LTE-Advanced standard, its full potential is yet to be realized. Drastically higher capacity can be obtained by leveraging higher number of antennas at the base station. In massive MIMO systems (also known as Very Large MIMO, VLM) the number of jointly precoded base station antennas per cell is larger than the number of users having thus desirable implications for coverage, inter-symbol and intra-cell interference control, and transmit power budget optimization [8]. Fortunately, most of the gains can be realized even at manageable antenna dimensions. It is expected that VLM will be a core technology to create significantly higher capacity either in the form of distributed radio heads with centralized processing or in deployment of hundreds of antenna elements in higher frequency bands such as mm-wave, where antenna dimensions become more practical.

Millimeter (mm)-wave Signals: 5G systems will need to provide significant improvement in cell capacity to accommodate the rapidly increasing traffic demands. Although 5G will introduce an array of new technologies that enable networks and devices to make better use of scarce spectrum resources, this will not be sufficient to keep pace with the mobile data requirement increase, which is expected to reach levels of gigabits per second. This could only be realized with much more spectrum than the

spectrum currently available to IMT systems through the International Telecommunications Union's (ITU) process. Due to the high fragmentation of existing spectrum in different regions of the world and due to the long time required for the spectrum re-farming, contiguous and broader frequency bands at higher frequencies is a promising way forward.

Millimeter (mm)-wave bands, between 30 and 300 GHz, where the available bandwidths are much wider than today's cellular networks are suitable for 5G communication systems [9]. Indeed, available spectrum at these frequencies can be 200 times greater than all cellular allocations today under 3 GHz. Moreover, the very small wavelengths of mmWave signals combined with advances in low-power CMOS RF circuits enable large number of miniaturized antennas to be placed in small dimensions. These multiple antenna systems can be used to form very high gain electrically steerable arrays, fabricated at the base station, in the skin of a cell phone, or even within a chip. Due to the limited range of mmWave signals, 5G systems will include a large number of pico-cells (100 to 200m radius), each using high directional antennas for improved range and spatial separation. Combining dramatically increased bandwidths with spatial multiplexing gains from the high dimensional multiple antenna transmissions, mmWave systems offer the possibility of tremendous capacity gain compared to current commercial networks.

Direct Device to Device (D2D): D2D communication enables the exchange of data traffic directly between user equipment without the use of base stations or the core network, other than for assistance in setting up direct connections. D2D communication supports new usage models based on the proximity of users, including social networking applications, peer-to-peer content sharing, and public safety communications in the absence of network coverage. Additionally, D2D communication serves as another "cell tier" in the 5G HetNet, where clusters of devices cooperate with each other to dramatically increase network capacity, by either reusing the same spectrum as the macro cell or by using unlicensed spectrum. In [10], it is shown that if devices use their direct connectivity capabilities whenever possible, cellular traffic can be effectively offloaded onto D2D links. Fig. 2 shows that significant gains in area throughput, as a function of offload percentage, can be achieved by offloading data onto WiFi-Direct (WFD) links. D2D communication also presents additional benefits beyond increased area spectral efficiency, including improved cellular coverage, reduced end-to-end latency and reduced power consumption.

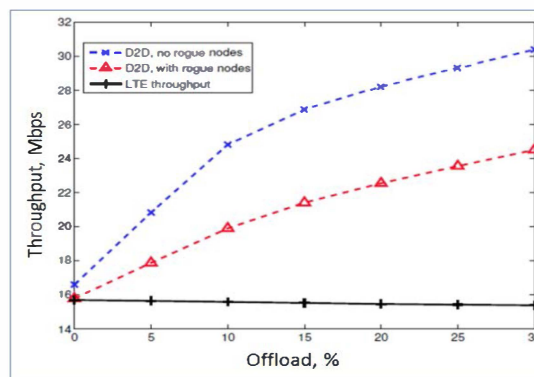

Fig. 2 Throughput in LTE network with D2D links offloaded to WiFi-direct, with and without interfering WiFi links (rogue nodes).

Full Duplex (FD) wireless: Full duplex enables a wireless device to transmit and receive data simultaneously in the same frequency band. It is a promising technology for 5G wireless systems as it potentially increases physical layer capacity by a factor of two, improves latency of feedback mechanisms, provides security in physical layer, amongst other benefits. In full duplex, the received signal at the wireless device is corrupted by direct interference from transmitted signal at the same node. As such, self-interference power is much higher than the received signal. Thus, the key challenge in realizing a full duplex system is how to suppress self-interference, especially before the low noise amplifier (LNA). Recently, there has been revival of interest in the research community in addressing the self-interference suppression problem to enable full duplex [11]. Various RF, analog, and digital self-interference cancellation techniques have been proposed that can provide up to 120 dB self-interference cancellation, enabling full duplex communications over femto-cell and Wi-Fi devices.

In addition to doubling spectral efficiency in point-to-point communication scenarios, FD can also improve network efficiency in contention based networks such as Wi-Fi by eliminating the hidden node problem. While receiving a designated packet, a node can transmit another packet in the opposite direction by making use of FD capability. This not only doubles the throughput, but also enables other nodes to better detect active nodes in their neighborhood in a timely manner. On the other hand, when the node has no packet to send, it can transmit some feedback message so that any hidden node can detect the activity in its vicinity and realize that the channel is in use. As a result the system throughput can be dramatically increased in Carrier Sense Multiple Access (CSMA) systems [12]. In Fig. 3, it is seen that STR achieves ideal CSMA throughput for different values of parameter ‘ h ’, which represents percentage of elapsed time for detecting received signal energy relative to packet duration. Larger ‘ h ’ typically results in more collisions, however STR minimizes this effect.

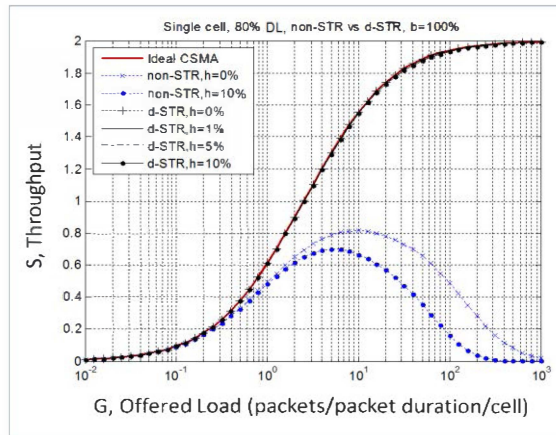

Fig. 3 STR can achieve ideal throughput in CSMA systems equivalent to no hidden node present.

III. NETWORK ARCHITECTURE

As it can be understood from the description above, 5G networks have to accommodate various types of traffic, devices and the network itself is anticipated to be consisted of nodes of various characteristics and capacities. This implies that the user

experience and quality should be maintained as users move along various networks and get connected to various types of nodes. Multi-layer network architecture approaches may be envisaged, where the macro layer provides coverage to users moving at high speeds or for secure control channels, and a lower layer comprising of network nodes with smaller capabilities provides high data rates and connectivity to various technologies. Moreover, expansion of phantom cell and other dual connectivity approaches may be imagined. Dual connectivity allows a given device to have simultaneous active connections to more than one network nodes, with the same or different RATs, each connection serving a specific purpose, e.g. one connection to a given node for data and a second connection to another node for control. In addition, the use of remote radio heads connected to central processing nodes with the aid of ultra-high speed backhaul is expected to be extended to more areas. Fast and high capacity backhaul will enable tighter coordination between various network nodes within a larger area. All of these evolutions combined with the increase in the direct device to device connections necessitate high level of integration of different nodes in the network and of technologies located even within the same node.

IV. DEVICE CONFIGURATION

As the 5G usage models and networks are still evolving and not limited to the use any particular frequency bands, 5G architectures will be more complex than the current 4G approach. Devices in the 5G networks should be capable of operating in multiple spectrum bands, ranging from RF to mm-wave, while being compatible with existing technologies such as 3G and 4G. Due to the need for offering best possible service to the desired traffic, devices should actively manage all the available network connections including D2D links, as well as share contextual information with network layers so that network resources can be efficiently utilized.

Fig. 4 outlines the characteristics of an example 5G wireless device platform concept. The need to support several RATs with multiple RF-chains imposes tremendous challenges for 5G device chipset and front-end module suppliers as well as system and platform integrators. The requirements for cell edge enhancement and the need for higher-order spatial multiplexing also increase the complexity of the antenna systems.

Another key component of 5G devices is the advanced baseband signal processing chain [13]. The even denser deployment of network nodes combined with various sources of interference require that the devices must be able to autonomously detect, characterize and suppress interference from any source including intra-cell, inter-cell as well as D2D interferences. The task of interference cancellation is exacerbated by the existence of strong self-interference in the case of simultaneous transmission and reception. Furthermore, the advanced signal processing within mobile terminals will not be limited to interference suppression only. Features such as massive MIMO coupled with mmWave frequency challenges will also require such advanced signal processing.

All of these enhanced features have to be implemented in a way that energy consumption is optimized with a small form factor wireless device platform. As energy efficiency will be an important feature for 5G user experience, it is desirable that the devices integrate energy efficiency metrics in connectivity management, and include energy harvesting technologies within the wireless system architecture.

V. SUMMARY

In this paper, the key enabling technologies, and main challenges of the radio interface of 5G cellular systems are presented. In order to address the technical issues related to 5G evolution and implementation, detailed research on both device and network needs to be accomplished.

REFERENCES

- [1] Cisco, "Cisco Visual Network Index: Global Mobile Traffic Forecast Update," 2013.
- [2] Ericsson, "Traffic and Market Data Report," 2011.
- [3] Ericsson, "More Than 50 Billion Connected Devices," White Paper [online]
<http://www.ericsson.com/res/docs/whitepapers/wp-50-billions.pdf>, 2011.
- [4] G. Fettweis, "The Tactile Internet Enabled By 5G," Presentation at Johannesburg Summit 2013 [online]
<http://www.youtube.com/watch?v=VXEPzQgpok>.
- [5] S. Talwar et al., "5G: Transforming the Wireless User Experience," Intel request for proposals, September 12, 2012.
- [6] METIS Project, deliverables, [online]
<http://www.metis2020.com/documents/deliverables>.
- [7] A. Y. Panah et al., "Utility-Based Radio Link Assignment in Multi-Radio Heterogeneous Networks," in *Proceedings of IEEE Globecom workshop on LTE and Beyond 4G Technologies*, Dec. 2012.
- [8] T. L. Marzetta, "Noncooperative cellular wireless with unlimited number of base station antennas," in *IEEE Transactions on Wireless Communications*, Vol.6, No. 1-2, pp. 1-163, 2011.
- [9] S. Rangan et al., "Millimeter wave cellular wireless networks: potentials and challenges," in *arXiv:1401.2560*, January 2014.
- [10] A. Pyattaev et al., "3GPP LTE Traffic Offloading onto WiFi Direct," *IEEE WCNC Workshop on Mobile Internet*, January 2013.

- [11] A. Sabharwal et al., "In-band full-duplex wireless: challenges and opportunities," in *arXiv:1311.0456*, November 2013.
- [12] Yang-Seok Choi et al., "Simultaneous Transmission and Reception: Algorithm, Design and System Level Performance," in *IEEE Transactions on Wireless Communications*, Vol. 12, No. 12, Dec. 2013
- [13] B. Bangerter, S. Talwar, et al., "Networks and Devices for the 5G Era," *IEEE Communications Magazine*, February 2014.

TABLE - I

Sector throughput gain with Integrated WiFi-LTE small cell relative to LTE-only small cell offload

Sector Throughput (Mbps)	Macro	Total (Macro + 4 Pico)
Macro Only	15.6	
LTE Offload	10.3 (1.0x)	79.4 (1.0x)
Integrated WiFi-LTE	19.4 (1.9x)	176.1 (2.2x)

TABLE - II

Cell-edge throughput gain with Integrated WiFi-LTE small cell relative to LTE-only small cell offload

Cell-edge Throughput (Mbps)	Macro	Total (Macro + 4 Pico)
Macro Only	0.1	
LTE Offload	0.5 (1.0x)	0.5 (1.0x)
Integrated WiFi-LTE	0.9 (1.8x)	1.7 (3.4x)

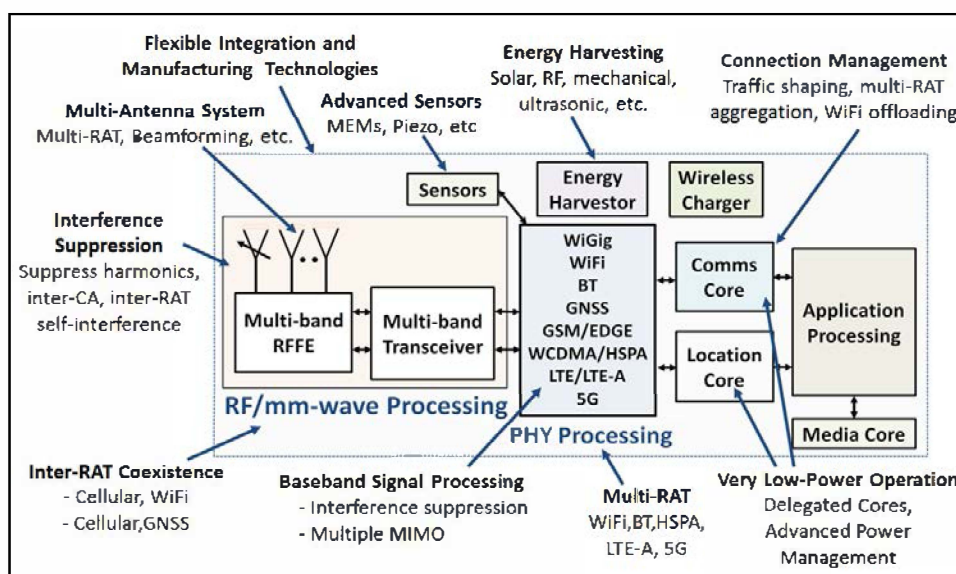

Fig.4 Example 5G Wireless Device Platform Concept.